



Programmable Controller

MELSEC iQ-R
series

MELSEC iQ-R Temperature Control Module User's Manual (Application)

-R60TCRT2TT2
-R60TCRT2TT2BW
-R60TCRT4
-R60TCRT4BW



SAFETY PRECAUTIONS

(Read these precautions before using this product.)

Before using this product, please read this manual and the relevant manuals carefully and pay full attention to safety to handle the product correctly.

The precautions given in this manual are concerned with this product only. For the safety precautions of the programmable controller system, refer to the MELSEC iQ-R Module Configuration Manual.

In this manual, the safety precautions are classified into two levels: "⚠ WARNING" and "⚠ CAUTION".

 WARNING	Indicates that incorrect handling may cause hazardous conditions, resulting in death or severe injury.
 CAUTION	Indicates that incorrect handling may cause hazardous conditions, resulting in minor or moderate injury or property damage.

Under some circumstances, failure to observe the precautions given under "⚠ CAUTION" may lead to serious consequences.

Observe the precautions of both levels because they are important for personal and system safety.

Make sure that the end users read this manual and then keep the manual in a safe place for future reference.

[Design Precautions]

WARNING

- Configure safety circuits external to the programmable controller to ensure that the entire system operates safely even when a fault occurs in the external power supply or the programmable controller. Failure to do so may result in an accident due to an incorrect output or malfunction.
 - (1) Emergency stop circuits, protection circuits, and protective interlock circuits for conflicting operations (such as forward/reverse rotations or upper/lower limit positioning) must be configured external to the programmable controller.
 - (2) When the programmable controller detects an abnormal condition, it stops the operation and all outputs are:
 - Turned off if the overcurrent or overvoltage protection of the power supply module is activated.
 - Held or turned off according to the parameter setting if the self-diagnostic function of the CPU module detects an error such as a watchdog timer error.
 - (3) All outputs may be turned on if an error occurs in a part, such as an I/O control part, where the CPU module cannot detect any error. To ensure safety operation in such a case, provide a safety mechanism or a fail-safe circuit external to the programmable controller. For a fail-safe circuit example, refer to "General Safety Requirements" in the MELSEC iQ-R Module Configuration Manual.
 - (4) Outputs may remain on or off due to a failure of a component such as a relay and transistor in an output circuit. Configure an external circuit for monitoring output signals that could cause a serious accident.
 - In an output circuit, when a load current exceeding the rated current or an overcurrent caused by a load short-circuit flows for a long time, it may cause smoke and fire. To prevent this, configure an external safety circuit, such as a fuse.
 - Configure a circuit so that the programmable controller is turned on first and then the external power supply. If the external power supply is turned on first, an accident may occur due to an incorrect output or malfunction.
 - For the operating status of each station after a communication failure, refer to manuals relevant to the network. Incorrect output or malfunction due to a communication failure may result in an accident.
 - When connecting an external device with a CPU module or intelligent function module to modify data of a running programmable controller, configure an interlock circuit in the program to ensure that the entire system will always operate safely. For other forms of control (such as program modification, parameter change, forced output, or operating status change) of a running programmable controller, read the relevant manuals carefully and ensure that the operation is safe before proceeding. Improper operation may damage machines or cause accidents.
 - Especially, when a remote programmable controller is controlled by an external device, immediate action cannot be taken if a problem occurs in the programmable controller due to a communication failure. To prevent this, configure an interlock circuit in the program, and determine corrective actions to be taken between the external device and CPU module in case of a communication failure.
 - Do not write any data to the "system area" and "write-protect area" of the buffer memory in the module. Also, do not use any "use prohibited" signals as an output signal from the CPU module to each module. Doing so may cause malfunction of the programmable controller system. For the "system area", "write-protect area", and the "use prohibited" signals, refer to the user's manual for the module used.
-

[Design Precautions]

WARNING

- If a communication cable is disconnected, the network may be unstable, resulting in a communication failure of multiple stations. Configure an interlock circuit in the program to ensure that the entire system will always operate safely even if communications fail. Failure to do so may result in an accident due to an incorrect output or malfunction.
 - To maintain the safety of the programmable controller system against unauthorized access from external devices via the network, take appropriate measures. To maintain the safety against unauthorized access via the Internet, take measures such as installing a firewall.
-

[Design Precautions]

CAUTION

- Do not install the control lines or communication cables together with the main circuit lines or power cables. Keep a distance of 100mm or more between them. Failure to do so may result in malfunction due to noise.
 - During control of an inductive load such as a lamp, heater, or solenoid valve, a large current (approximately ten times greater than normal) may flow when the output is turned from off to on. Therefore, use a module that has a sufficient current rating.
 - After the CPU module is powered on or is reset, the time taken to enter the RUN status varies depending on the system configuration, parameter settings, and/or program size. Design circuits so that the entire system will always operate safely, regardless of the time.
 - Do not power off the programmable controller or reset the CPU module while the settings are being written. Doing so will make the data in the flash ROM undefined. The values need to be set in the buffer memory and written to the flash ROM again. Doing so also may cause malfunction or failure of the module.
 - When changing the operating status of the CPU module from external devices (such as the remote RUN/STOP functions), select "Do Not OPEN in Program" for "Open Method Setting" in the module parameters. If "OPEN in Program" is selected, an execution of the remote STOP function causes the communication line to close. Consequently, the CPU module cannot reopen the line, and external devices cannot execute the remote RUN function.
-

[Installation Precautions]

WARNING

- Shut off the external power supply (all phases) used in the system before mounting or removing the module. Failure to do so may result in electric shock or cause the module to fail or malfunction.
-

[Installation Precautions]

CAUTION

- Use the programmable controller in an environment that meets the general specifications in the Safety Guidelines included with the base unit. Failure to do so may result in electric shock, fire, malfunction, or damage to or deterioration of the product.
 - To mount a module, place the concave part(s) located at the bottom onto the guide(s) of the base unit, and push in the module until the hook(s) located at the top snaps into place. Incorrect interconnection may cause malfunction, failure, or drop of the module.
 - When using the programmable controller in an environment of frequent vibrations, fix the module with a screw.
 - Tighten the screws within the specified torque range. Undertightening can cause drop of the screw, short circuit, or malfunction. Overtightening can damage the screw and/or module, resulting in drop, short circuit, or malfunction.
 - When using an extension cable, connect it to the extension cable connector of the base unit securely. Check the connection for looseness. Poor contact may cause malfunction.
 - When using an SD memory card, fully insert it into the SD memory card slot. Check that it is inserted completely. Poor contact may cause malfunction.
 - Securely insert an extended SRAM cassette into the cassette connector of the CPU module. After insertion, close the cassette cover and check that the cassette is inserted completely. Poor contact may cause malfunction.
 - Do not directly touch any conductive parts and electronic components of the module, SD memory card, extended SRAM cassette, or connector. Doing so can cause malfunction or failure of the module.
-

[Wiring Precautions]

WARNING

- Shut off the external power supply (all phases) used in the system before installation and wiring. Failure to do so may result in electric shock or cause the module to fail or malfunction.
 - After installation and wiring, attach the included terminal cover to the module before turning it on for operation. Failure to do so may result in electric shock.
-

[Wiring Precautions]

CAUTION

- Individually ground the FG and LG terminals of the programmable controller with a ground resistance of 100 ohms or less. Failure to do so may result in electric shock or malfunction.
 - Use applicable solderless terminals and tighten them within the specified torque range. If any spade solderless terminal is used, it may be disconnected when the terminal screw comes loose, resulting in failure.
 - Check the rated voltage and signal layout before wiring to the module, and connect the cables correctly. Connecting a power supply with a different voltage rating or incorrect wiring may cause fire or failure.
 - Connectors for external devices must be crimped or pressed with the tool specified by the manufacturer, or must be correctly soldered. Incomplete connections may cause short circuit, fire, or malfunction.
 - Securely connect the connector to the module. Poor contact may cause malfunction.
 - Do not install the control lines or communication cables together with the main circuit lines or power cables. Keep a distance of 100mm or more between them. Failure to do so may result in malfunction due to noise.
 - Place the cables in a duct or clamp them. If not, dangling cable may swing or inadvertently be pulled, resulting in damage to the module or cables or malfunction due to poor contact. Do not clamp the extension cables with the jacket stripped. Doing so may change the characteristics of the cables, resulting in malfunction.
 - Check the interface type and correctly connect the cable. Incorrect wiring (connecting the cable to an incorrect interface) may cause failure of the module and external device.
 - Tighten the terminal screws or connector screws within the specified torque range. Undertightening can cause drop of the screw, short circuit, fire, or malfunction. Overtightening can damage the screw and/or module, resulting in drop, short circuit, fire, or malfunction.
 - When disconnecting the cable from the module, do not pull the cable by the cable part. For the cable with connector, hold the connector part of the cable. For the cable connected to the terminal block, loosen the terminal screw. Pulling the cable connected to the module may result in malfunction or damage to the module or cable.
 - Prevent foreign matter such as dust or wire chips from entering the module. Such foreign matter can cause a fire, failure, or malfunction.
 - A protective film is attached to the top of the module to prevent foreign matter, such as wire chips, from entering the module during wiring. Do not remove the film during wiring. Remove it for heat dissipation before system operation.
 - Programmable controllers must be installed in control panels. Connect the main power supply to the power supply module in the control panel through a relay terminal block. Wiring and replacement of a power supply module must be performed by qualified maintenance personnel with knowledge of protection against electric shock. For wiring, refer to the MELSEC iQ-R Module Configuration Manual.
 - For Ethernet cables to be used in the system, select the ones that meet the specifications in the user's manual for the module used. If not, normal data transmission is not guaranteed.
-

[Wiring Precautions]

CAUTION

- Individually ground the shielded cables of the programmable controller with a ground resistance of 100 ohms or less. Failure to do so may result in electric shock or malfunction.
-

[Startup and Maintenance Precautions]

WARNING

- Do not touch any terminal while power is on. Doing so will cause electric shock or malfunction.
 - Correctly connect the battery connector. Do not charge, disassemble, heat, short-circuit, solder, or throw the battery into the fire. Also, do not expose it to liquid or strong shock. Doing so will cause the battery to produce heat, explode, ignite, or leak, resulting in injury and fire.
 - Shut off the external power supply (all phases) used in the system before cleaning the module or retightening the terminal screws, connector screws, or module fixing screws. Failure to do so may result in electric shock.
-

[Startup and Maintenance Precautions]

CAUTION

- When connecting an external device with a CPU module or intelligent function module to modify data of a running programmable controller, configure an interlock circuit in the program to ensure that the entire system will always operate safely. For other forms of control (such as program modification, parameter change, forced output, or operating status change) of a running programmable controller, read the relevant manuals carefully and ensure that the operation is safe before proceeding. Improper operation may damage machines or cause accidents.
 - Especially, when a remote programmable controller is controlled by an external device, immediate action cannot be taken if a problem occurs in the programmable controller due to a communication failure. To prevent this, configure an interlock circuit in the program, and determine corrective actions to be taken between the external device and CPU module in case of a communication failure.
 - Do not disassemble or modify the modules. Doing so may cause failure, malfunction, injury, or a fire.
 - Use any radio communication device such as a cellular phone or PHS (Personal Handy-phone System) more than 25cm away in all directions from the programmable controller. Failure to do so may cause malfunction.
 - Shut off the external power supply (all phases) used in the system before mounting or removing the module. Failure to do so may cause the module to fail or malfunction.
 - Tighten the screws within the specified torque range. Undertightening can cause drop of the component or wire, short circuit, or malfunction. Overtightening can damage the screw and/or module, resulting in drop, short circuit, or malfunction.
 - After the first use of the product, do not mount/remove the module to/from the base unit, and the terminal block to/from the module, and do not insert/remove the extended SRAM cassette to/from the CPU module more than 50 times (IEC 61131-2 compliant) respectively. Exceeding the limit may cause malfunction.
 - After the first use of the product, do not insert/remove the SD memory card to/from the CPU module more than 500 times. Exceeding the limit may cause malfunction.
 - Do not touch the metal terminals on the back side of the SD memory card. Doing so may cause malfunction or failure of the module.
 - Do not touch the integrated circuits on the circuit board of an extended SRAM cassette. Doing so may cause malfunction or failure of the module.
 - Do not drop or apply shock to the battery to be installed in the module. Doing so may damage the battery, causing the battery fluid to leak inside the battery. If the battery is dropped or any shock is applied to it, dispose of it without using.
 - Startup and maintenance of a control panel must be performed by qualified maintenance personnel with knowledge of protection against electric shock. Lock the control panel so that only qualified maintenance personnel can operate it.
 - Before handling the module, touch a conducting object such as a grounded metal to discharge the static electricity from the human body. Failure to do so may cause the module to fail or malfunction.
-

[Operating Precautions]

CAUTION

- When changing data and operating status, and modifying program of the running programmable controller from an external device such as a personal computer connected to an intelligent function module, read relevant manuals carefully and ensure the safety before operation. Incorrect change or modification may cause system malfunction, damage to the machines, or accidents.
 - Do not power off the programmable controller or reset the CPU module while the setting values in the buffer memory are being written to the flash ROM in the module. Doing so will make the data in the flash ROM undefined. The values need to be set in the buffer memory and written to the flash ROM again. Doing so can cause malfunction or failure of the module.
-

[Disposal Precautions]

CAUTION

- When disposing of this product, treat it as industrial waste.
 - When disposing of batteries, separate them from other wastes according to the local regulations. For details on battery regulations in EU member states, refer to the MELSEC iQ-R Module Configuration Manual.
-

[Transportation Precautions]

CAUTION

- When transporting lithium batteries, follow the transportation regulations. For details on the regulated models, refer to the MELSEC iQ-R Module Configuration Manual.
 - The halogens (such as fluorine, chlorine, bromine, and iodine), which are contained in a fumigant used for disinfection and pest control of wood packaging materials, may cause failure of the product. Prevent the entry of fumigant residues into the product or consider other methods (such as heat treatment) instead of fumigation. The disinfection and pest control measures must be applied to unprocessed raw wood.
-

CONDITIONS OF USE FOR THE PRODUCT

(1) Mitsubishi programmable controller ("the PRODUCT") shall be used in conditions;

- i) where any problem, fault or failure occurring in the PRODUCT, if any, shall not lead to any major or serious accident; and
- ii) where the backup and fail-safe function are systematically or automatically provided outside of the PRODUCT for the case of any problem, fault or failure occurring in the PRODUCT.

(2) The PRODUCT has been designed and manufactured for the purpose of being used in general industries.

MITSUBISHI SHALL HAVE NO RESPONSIBILITY OR LIABILITY (INCLUDING, BUT NOT LIMITED TO ANY AND ALL RESPONSIBILITY OR LIABILITY BASED ON CONTRACT, WARRANTY, TORT, PRODUCT LIABILITY) FOR ANY INJURY OR DEATH TO PERSONS OR LOSS OR DAMAGE TO PROPERTY CAUSED BY the PRODUCT THAT ARE OPERATED OR USED IN APPLICATION NOT INTENDED OR EXCLUDED BY INSTRUCTIONS, PRECAUTIONS, OR WARNING CONTAINED IN MITSUBISHI'S USER, INSTRUCTION AND/OR SAFETY MANUALS, TECHNICAL BULLETINS AND GUIDELINES FOR the PRODUCT.

("Prohibited Application")

Prohibited Applications include, but not limited to, the use of the PRODUCT in;

- Nuclear Power Plants and any other power plants operated by Power companies, and/or any other cases in which the public could be affected if any problem or fault occurs in the PRODUCT.
- Railway companies or Public service purposes, and/or any other cases in which establishment of a special quality assurance system is required by the Purchaser or End User.
- Aircraft or Aerospace, Medical applications, Train equipment, transport equipment such as Elevator and Escalator, Incineration and Fuel devices, Vehicles, Manned transportation, Equipment for Recreation and Amusement, and Safety devices, handling of Nuclear or Hazardous Materials or Chemicals, Mining and Drilling, and/or other applications where there is a significant risk of injury to the public or property.

Notwithstanding the above, restrictions Mitsubishi may in its sole discretion, authorize use of the PRODUCT in one or more of the Prohibited Applications, provided that the usage of the PRODUCT is limited only for the specific applications agreed to by Mitsubishi and provided further that no special quality assurance or fail-safe, redundant or other safety features which exceed the general specifications of the PRODUCTS are required. For details, please contact the Mitsubishi representative in your region.

INTRODUCTION

Thank you for purchasing the Mitsubishi MELSEC iQ-R series programmable controllers.

This manual describes the performance specifications, procedures before operation, wiring, and operation examples of the relevant products listed below.

Before using this product, please read this manual and the relevant manuals carefully and develop familiarity with the functions and performance of the MELSEC iQ-R series programmable controller to handle the product correctly.

When applying the program and circuit examples provided in this manual to an actual system, ensure the applicability and confirm that it will not cause system control problems.

Please make sure that the end users read this manual.

Relevant products

R60TCRT2TT2, R60TCRT2TT2BW, R60TCRT4, R60TCRT4BW

CONTENTS

SAFETY PRECAUTIONS	1
CONDITIONS OF USE FOR THE PRODUCT	9
INTRODUCTION	9
RELEVANT MANUALS	13
TERMS	13
CHAPTER 1 FUNCTIONS	14
1.1 Control Mode Selection Function	14
1.2 Control Method	16
1.3 Sampling Cycle Switching Function	23
1.4 Control Output Cycle Unit Selection Function	23
1.5 HOLD/CLEAR Function	24
1.6 Overlap/dead Band Function	26
1.7 Manual Reset Function	29
1.8 Cooling Method Setting Function	31
1.9 Temperature Conversion Function (Using Unused Channels)	32
1.10 Manual Control	34
1.11 Auto Tuning Function	35
1.12 Self-tuning Function	44
1.13 Direct/reverse Action Selection Function	51
1.14 RFB Limiter Function	51
1.15 Derivative Action Selection Function	52
1.16 Simple Two-degree-of-freedom	53
1.17 Auto-setting at Input Range Change	54
1.18 Setting Variation Rate Limiter Setting Function	55
1.19 Sensor Correction Function	56
1.20 Primary Delay Digital Filter	64
1.21 Moving Average Processing	65
1.22 Scaling Function	65
1.23 ON Delay Output Function	67
1.24 Input/output (with Another Analog Module) Function	68
1.25 Alert Function	69
1.26 Rate Alarm Function	79
1.27 Heater Disconnection Detection Function	83
1.28 Output Off-time Current Error Detection Function	87
1.29 Loop Disconnection Detection Function	88
1.30 During AT Loop Disconnection Detection Function	90
1.31 Peak Current Suppression Function	92
1.32 Simultaneous Temperature Rise Function	97
1.33 Inter-module Link Function	108
Inter-module peak current suppression function	108
Inter-module simultaneous temperature rise function	110
1.34 Proportional Band Setting Function	112
1.35 Disturbance Suppression Function	113
1.36 Buffer Memory Data Backup Function	119
1.37 Overshoot Suppression Function	121
1.38 Error History Function	123
1.39 Event History Function	126

1.40	Interrupt Function	127
1.41	Q Compatible Mode Function	130
CHAPTER 2 PARAMETER SETTING		131
2.1	Basic Setting	131
2.2	Application Setting	132
2.3	CT Setting	133
2.4	Interrupt Setting	134
2.5	Refresh Settings	135
	Refresh processing time	136
CHAPTER 3 TROUBLESHOOTING		137
3.1	Checks Using LEDs	137
	When the RUN LED flashes or turns off	137
	When the ERR LED turns on	137
	When the ALM LED turns on or flashes	138
	When the HBA LED turns on	138
3.2	Checking the Module Status	139
3.3	Troubleshooting by Symptom	140
3.4	List of Error Codes	142
3.5	List of Alarm Codes	146
APPENDICES		147
Appendix 1 Module Label		147
Appendix 2 I/O Signal		149
	List of I/O signals	149
	Details of input signals	150
	Details of output signals	158
Appendix 3 Buffer Memory Areas		161
	List of buffer memory addresses	161
	Details of buffer memory addresses	207
Appendix 4 PID		315
	PID control	315
	PID operation	317
	Actions of the temperature control module	318
	Proportional action (P action)	319
	Integral action (I action)	320
	Derivative action (D action)	321
	PID action	321
Appendix 5 Operation Examples of When the Remote Head Module Is Mounted		322
	System configuration example	322
	Setting in the master station	323
	Setting in the intelligent device station	326
	Checking the network status	328
	Program examples	328
Appendix 6 Restrictions for When the Remote Head Module Is Mounted		330
Appendix 7 Added or Enhanced Function		331
INDEX		333
REVISIONS		336

WARRANTY337
TRADEMARKS338

RELEVANT MANUALS

Manual name [manual number]	Description	Available form
MELSEC iQ-R Temperature Control Module User's Manual (Application) [SH-081536ENG] (this manual)	Functions, parameter settings, troubleshooting, I/O signals, and buffer memory of the temperature control module	Print book e-Manual PDF
MELSEC iQ-R Temperature Control Module User's Manual (Startup) [SH-081535ENG]	Specifications, procedures before operation, wiring, and operation examples of the temperature control module	Print book e-Manual PDF



e-Manual refers to the Mitsubishi FA electronic book manuals that can be browsed using a dedicated tool.

e-Manual has the following features:

- Required information can be cross-searched in multiple manuals.
- Other manuals can be accessed from the links in the manual.
- The hardware specifications of each part can be found from the product figures.
- Pages that users often browse can be bookmarked.
- Sample programs can be copied to an engineering tool.

TERMS

Unless otherwise specified, this manual uses the following terms.

Term	Description
AT point	The total of Set value (SV) setting and AT bias
Buffer memory	The intelligent function module's memory where the data (including setting values and monitored values) received/sent from/to the CPU module is stored
Control method	The generic term of two-position control, P control, PI control, PD control, and PID control
Control mode	The generic term of standard control, heating-cooling control (normal mode), heating-cooling control (expanded mode), mix control (normal mode), mix control (expanded mode), position proportional control (normal mode), and position proportional control (expanded mode)
CPU module	The generic term of MELSEC iQ-R series CPU modules
Engineering tool	The product name of the MELSEC programmable controller software package
Master/local module	The generic term of following modules of when an RJ71GF11-T2 CC-Link IE Field Network master/local module and a CC-Link IE Field Network function are used <ul style="list-style-type: none"> • RJ71EN71 • RnENCPU
PID constants	The generic term of the proportional band (P), integral time (I), and derivative time (D)
Q compatible mode	In this mode, the buffer memory map is converted into the one for the MELSEC-Q series and the module operates with the buffer memory map.
Remote head module	The abbreviation for the RJ72GF15-T2 CC-Link IE Field Network remote head module
R mode	In this mode, the module operates with the buffer memory map that has been newly assigned for the MELSEC iQ-R series.
Simultaneous temperature rise parameter	The generic term of simultaneous temperature rise dead time and simultaneous temperature rise gradient data

1 FUNCTIONS

This chapter describes the function details of the temperature control module.
For details on the I/O signals and buffer memory areas, refer to the following.

☞ Page 150 Details of input signals

☞ Page 158 Details of output signals

☞ Page 207 Details of buffer memory addresses

Point

This chapter describes the I/O signals and buffer memory addresses for CH1.
For details on the I/O signals for CH2 or later, refer to the following.

☞ Page 149 List of I/O signals

For details on the buffer memory addresses for CH2 or later, refer to the following.

☞ Page 161 List of buffer memory addresses

1.1 Control Mode Selection Function

A control mode can be selected using this function. This section describes control modes that can be selected for the temperature control module.

Standard control, heating-cooling control, position proportional control

There are three types of control modes in the temperature control module: Standard control, heating-cooling control, and position proportional control.

■Standard control

The control method is either one of heating (reverse action) or cooling (direct action). When the control method is heating, of a heater for example, cooling is controlled by simply turning off the heating. When the control method is cooling, of cold water for example, heating is controlled by simply turning off the cooling.

■Heating-cooling control

The control method is both heating and cooling. To heat up the target subject, its heating mean is turned on, and its cooling mean is turned off. To cool down the target subject, its heating mean is turned off, and its cooling mean is turned on.

■Position proportional control

The control method is either one of heating (reverse action) or cooling (direct action). Fluid flow is controlled with an electric-operated valve, and the process amount of such as temperature is controlled.

Selectable control mode

A control mode can be selected from the following seven modes. Select a control mode in "Control mode selection" of "Base Setting".

Control mode	Description	No. of control loops
Standard control	Executes the standard control of four channels.	Standard control 4 loops
Heating-cooling control (normal mode)	Executes the heating-cooling control. CH3 and CH4 cannot be used.	Heating-cooling control 2 loops
Heating-cooling control (expanded mode)	Executes the heating-cooling control. The number of loops is expanded using an output module and others in the system.	Heating-cooling control 4 loops
Mix control (normal mode)	Executes the standard control and the heating-cooling control. CH2 cannot be used.	<ul style="list-style-type: none"> Standard control 2 loops Heating-cooling control 1 loops
Mix control (expanded mode)	Executes the standard control and the heating-cooling control. The number of loops is expanded using an output module and others in the system.	<ul style="list-style-type: none"> Standard control 2 loops Heating-cooling control 2 loops
Position proportional control (normal mode)	Executes the position proportional control. CH3 and CH4 cannot be used.	Position proportional control 2 loops
Position proportional control (expanded mode)	Executes the position proportional control. The number of loops is expanded using an output module and others in the system.	Position proportional control 4 loops

Control for each channel is as follows.

Channel	Standard control	Heating-cooling control		Mix control		Position proportional control	
		Normal mode	Expanded mode	Normal mode	Expanded mode	Normal mode	Expanded mode
CH1	Standard control	Heating-cooling control	Heating-cooling control	Heating-cooling control	Heating-cooling control	Position proportional control	Position proportional control
CH2	Standard control	Heating-cooling control	Heating-cooling control	—*1	Heating-cooling control	Position proportional control	Position proportional control
CH3	Standard control	—*1	Heating-cooling control	Standard control	Standard control	—*1	Position proportional control
CH4	Standard control	—*1	Heating-cooling control	Standard control	Standard control	—*1	Position proportional control

*1 Only the temperature measurement using a temperature input terminal can be executed.

Expanded mode

In the heating-cooling control (expanded mode), mix control (expanded mode), or position proportional control (expanded mode), the number of loops for the heating-cooling control or position proportional control can be expanded using an output module and others in the system. To use an expanded mode, construct a system such as the one shown below.

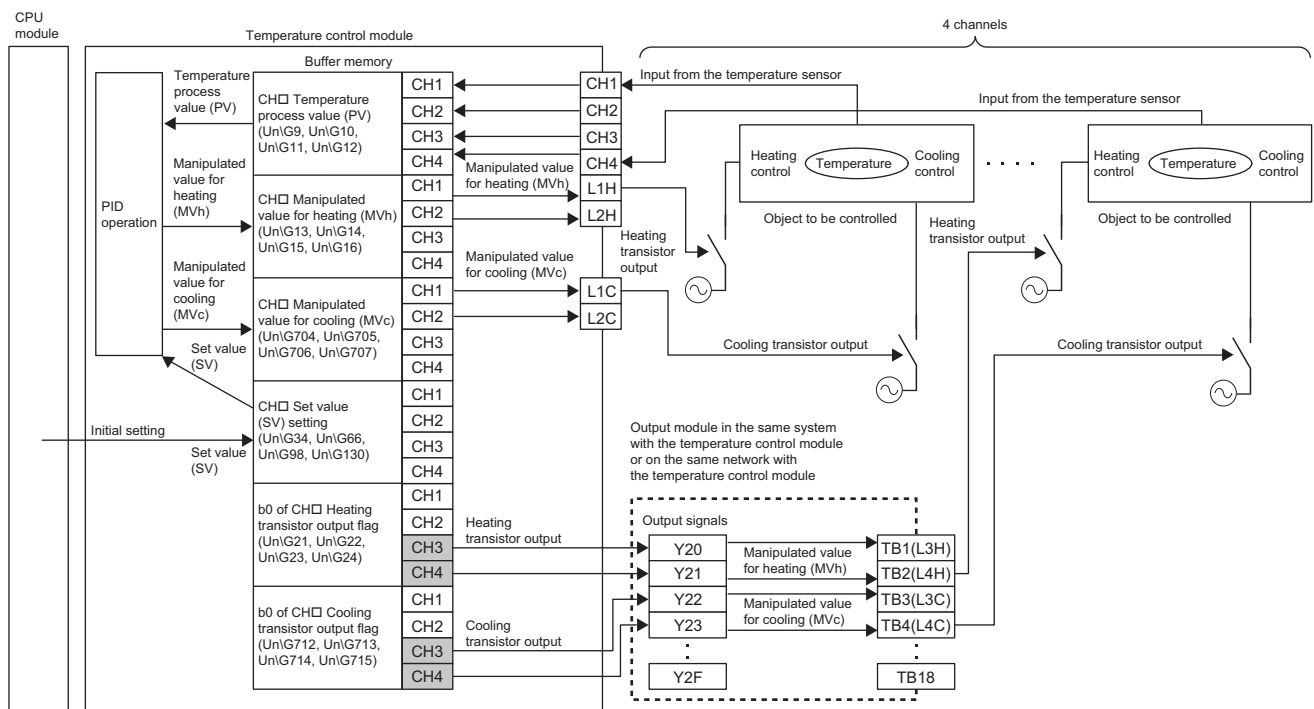

1.2 Control Method

The following control methods can be achieved by setting a proportional band (P), integral time (I), and derivative time (D).

- Two-position control
- P control
- PI control
- PD control
- PID control

Point

In the P control or PD control, the manual reset is enabled. (Page 29 Manual Reset Function)

Two-position control

Two-position control is a control method that uses the 0% manipulated value (MV) and 100% manipulated value (MV). Turning on and off the manipulated value (MV) repeatedly makes the temperature process value come close to the set value (SV), and the temperature is kept constant.

Point

By the setting in "Adjustment sensitivity (dead band) setting" of "Application Setting", the chattering of transistor outputs under two-position control can be prevented. Configure the setting for the set value (SV).

Standard control

The module operates as follows outside the setting range of "Adjustment sensitivity (dead band) setting" in "Application Setting".

Condition	Transistor output status
The temperature process value (PV) is below the lower limit of the adjustment sensitivity (dead band).	ON
The temperature process value (PV) is above the upper limit of the adjustment sensitivity (dead band).	OFF

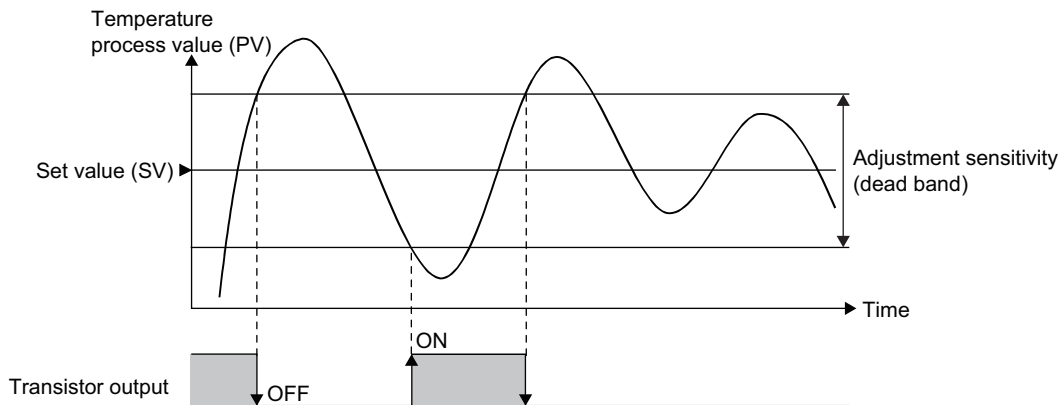

■ Heating-cooling control

The module operates as follows outside the setting range of "Adjustment sensitivity (dead band) setting" in "Application Setting".

Condition	Heating transistor output status	Cooling transistor output status
The temperature process value (PV) is below the lower limit of the adjustment sensitivity (dead band).	ON	OFF
The temperature process value (PV) is above the upper limit of the adjustment sensitivity (dead band).	OFF	ON

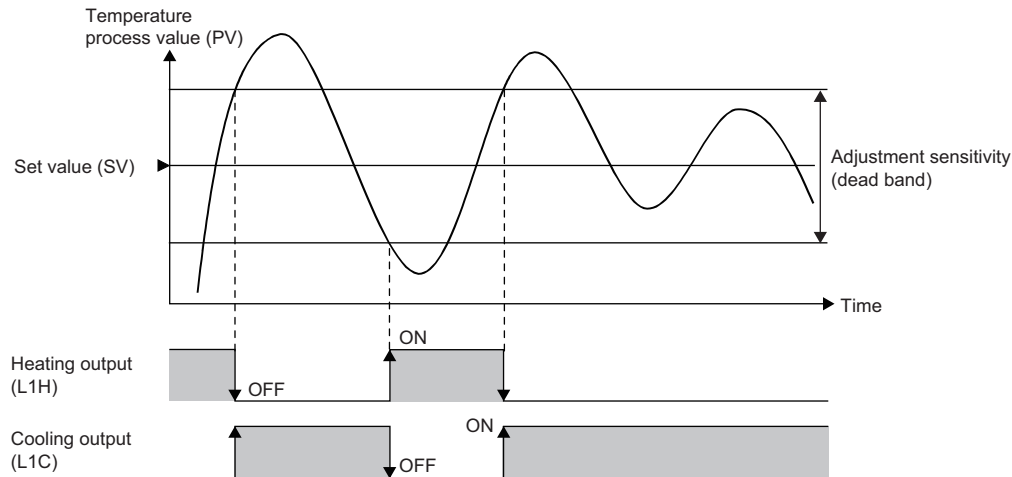

■ Three-position control

Three-position control can also be executed by setting a dead band. (☞ Page 28 Dead band setting in the two-position control (three-position control))

■ Setting method (in the R mode)

Set 0 (0°C (°F)) in the following buffer memory areas.

- 'CH1 Proportional band (P) setting' (Un\G431) (☞ Page 238 CH1 Proportional band (P) setting)
- 'CH1 Heating proportional band (Ph) setting' (Un\G431) (☞ Page 240 CH1 Heating proportional band (Ph) setting)

■ Setting method (in the Q compatible mode)

Set 0.0% for "Proportion Belt (P) Setting" of "Control basic parameters". (☞ Page 132 Application Setting)

☞ [Navigation window] ⇒ [Parameter] ⇒ [Module Information] ⇒ Target module ⇒ [Module Parameter] ⇒ [Application Setting] ⇒ [Control basic parameters]

P control

P control is a control method in which the manipulated value (MV) is determined proportional to the deviation (E) between the temperature process value (PV) and set value (SV).

■Standard control

The manipulated value (MV) is 50% in the following conditions.

- Temperature process value (PV) = Set value (SV)
- 'CH1 Manual reset amount setting' (Un\G517) has been set to 0 (0.0%) (☞ Page 263 CH1 Manual reset amount setting).

Manipulated value (MV)^{*1}

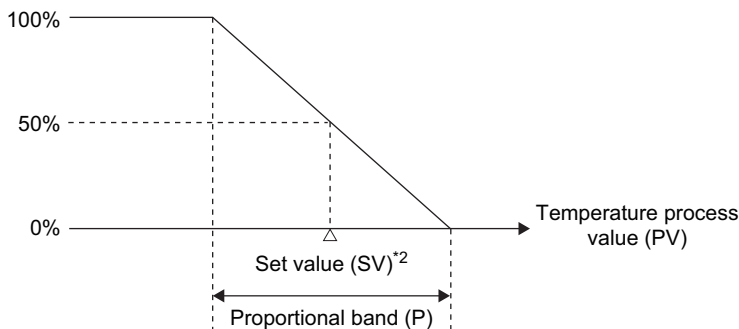

*1 A value to be actually output is within the output limiter range set in "Upper limit output limiter" and "Lower limit output limiter" of "Limiter setting" in "Application Setting".

*2 The set value (SV) is the center of the proportional band (P).

■Heating-cooling control

The manipulated value for heating (MVh) and the manipulated value for cooling (MVc) are both 0% in the following conditions.

- Temperature process value (PV) = Set value (SV)
- 'CH1 Manual reset amount setting' (Un\G517) has been set to 0 (0.0%) (☞ Page 263 CH1 Manual reset amount setting).

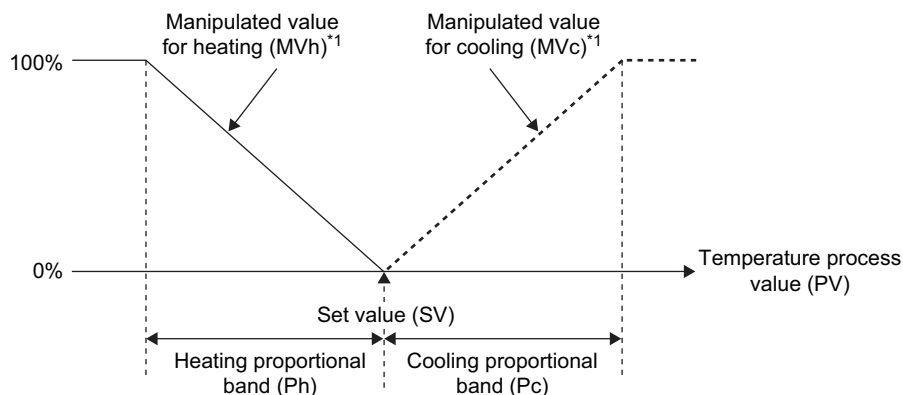

*1 A value to be actually output is within the output limiter range set in "Upper limit output limiter" and "Lower limit output limiter" of "Limiter setting" in "Application Setting". (☞ Page 132 Application Setting)

■Setting method (in the R mode)

Set each item as follows.

- 'CH1 Proportional band (P) setting' (Un\G431): Any value (☞ Page 238 CH1 Proportional band (P) setting)
- 'CH1 Heating proportional band (Ph) setting' (Un\G431): Any value (☞ Page 240 CH1 Heating proportional band (Ph) setting)
- 'CH1 Integral time (I) setting' (Un\G432): 0 (0s) (☞ Page 240 CH1 Integral time (I) setting)
- 'CH1 Derivative time (D) setting' (Un\G433): 0 (0s) (☞ Page 241 CH1 Derivative time (D) setting)

■Setting method (in the Q compatible mode)

Set each item as follows.

- "Proportion Belt (P) Setting": Any value
- "Integration Time (I) Setting": 0s
- "Differentiation Time (D) Setting": 0s





 [Navigation window] ⇒ [Parameter] ⇒ [Module Information] ⇒ Target module ⇒ [Module Parameter] ⇒ [Application Setting] ⇒ [Control basic parameters]

PI control

PI control is a control method in which derivative elements are added to P control, and thereby corrects an offset (remaining deviation) that remains when the temperature is stable. By setting the integral time (I) properly, the temperature process value (PV) matches with the set value (SV).

■Setting method (in the R mode)

Set each item as follows.

- 'CH1 Proportional band (P) setting' (Un\G431): Any value ( Page 238 CH1 Proportional band (P) setting)
- 'CH1 Heating proportional band (Ph) setting' (Un\G431): Any value ( Page 240 CH1 Heating proportional band (Ph) setting)
- 'CH1 Integral time (I) setting' (Un\G432): Any value ( Page 240 CH1 Integral time (I) setting)
- 'CH1 Derivative time (D) setting' (Un\G433): 0 (0s) ( Page 241 CH1 Derivative time (D) setting)

■Setting method (in the Q compatible mode)

Set each item as follows.

- "Proportion Belt (P) Setting": Any value
- "Integration Time (I) Setting": Any value
- "Differentiation Time (D) Setting": 0s





 [Navigation window] ⇒ [Parameter] ⇒ [Module Information] ⇒ Target module ⇒ [Module Parameter] ⇒ [Application Setting] ⇒ [Control basic parameters]

PD control

PD control is a control method in which the derivative time (D) is set in addition to P control. The control mechanism is the same as P control.

■Setting method (in the R mode)

Set each item as follows.

- 'CH1 Proportional band (P) setting' (Un\G431): Any value ( Page 238 CH1 Proportional band (P) setting)
- 'CH1 Heating proportional band (Ph) setting' (Un\G431): Any value ( Page 240 CH1 Heating proportional band (Ph) setting)
- 'CH1 Integral time (I) setting' (Un\G432): 0 (0s) ( Page 240 CH1 Integral time (I) setting)
- 'CH1 Derivative time (D) setting' (Un\G433): Any value ( Page 241 CH1 Derivative time (D) setting)

■Setting method (in the Q compatible mode)

Set each item as follows.

- "Proportion Belt (P) Setting": Any value
- "Integration Time (I) Setting": 0s
- "Differentiation Time (D) Setting": Any value

 [Navigation window] ⇒ [Parameter] ⇒ [Module Information] ⇒ Target module ⇒ [Module Parameter] ⇒ [Application Setting] ⇒ [Control basic parameters]

PID control

PID control is a control method in which derivative elements are added to PI control, and thereby the temperature shifts to a stable status in a short period of time even when a drastic change has occurred. By setting the derivative time (D) properly, the controlled object shifts to a stable status in a short period of time.

■Setting method (in the R mode)

Set each item as follows.

- 'CH1 Proportional band (P) setting' (Un\G431): Any value (☞ Page 238 CH1 Proportional band (P) setting)
- 'CH1 Heating proportional band (Ph) setting' (Un\G431): Any value (☞ Page 240 CH1 Heating proportional band (Ph) setting)
- 'CH1 Integral time (I) setting' (Un\G432): Any value (☞ Page 240 CH1 Integral time (I) setting)
- 'CH1 Derivative time (D) setting' (Un\G433): Any value (☞ Page 241 CH1 Derivative time (D) setting)

■Setting method (in the Q compatible mode)

Set each item as follows.

- "Proportion Belt (P) Setting": Any value
- "Integration Time (I) Setting": Any value
- "Differentiation Time (D) Setting": Any value

☞ [Navigation window] ⇒ [Parameter] ⇒ [Module Information] ⇒ Target module ⇒ [Module Parameter] ⇒ [Application Setting] ⇒ [Control basic parameters]

Condition to execute the PID control

Whether PID control is executed or not depends on the following settings:

- 'Setting/operation mode command' (Y1)
- "PID continuation Flag" of "Control basic parameters" in "Application Setting"
- 'CH1 PID control forced stop command' (YC)
- "Stop mode setting" of "Control basic parameters" in "Application Setting"

The following table shows the relation between each setting and the execution of PID control.

Executed: ○, Not executed: ×

'Setting/operation mode command' (Y1)* ²	"PID continuation Flag" of "Control basic parameters" in "Application Setting"	'CH1 PID control forced stop command' (YC)	"Stop mode setting" of "Control basic parameters" in "Application Setting"	Control status of PID control* ¹	
Setting mode at power-on	Stop (0), Continue (1)	OFF, ON	Stop (0), Monitor (1), Alert (2)	×	
Operation mode (during operation)	Stop (0), Continue (1)	OFF	Stop (0), Monitor (1), Alert (2)	○	
		ON	Stop (0), Monitor (1), Alert (2)	×	
Setting mode (after operation)	Stop (0)	OFF, ON	Stop (0), Monitor (1), Alert (2)	×	
		Continue (1)	OFF	Stop (0), Monitor (1), Alert (2)	○
			ON	Stop (0), Monitor (1), Alert (2)	×

*1 Here, this term is the generic term of two-position control, P control, PI control, PD control, and PID control.

*2 For each timing, refer to the following.

☞ Page 151 Setting/operation mode status

Even though the above conditions have been satisfied, PID control is not executed when "Unused channel setting" of "Control basic parameters" in "Application Setting" has been set to "Unused (1)".

The manipulated value (MV) and the manipulated value (MV) for output with another analog module of when 'CH1 PID control forced stop command' (YC) is turned off and on are as follows.

Buffer memory area name	Buffer memory address	Stored value	Reference
CH1 Manipulated value (MV)	403	-50 (-5.0%)	Page 226 CH1 Manipulated value (MV)
CH1 Manipulated value (MV) for output with another analog module	407	0	Page 229 CH1 Manipulated value (MV) for output with another analog module
CH1 Manipulated value for heating (MVh)	403	-50 (-5.0%)	Page 226 CH1 Manipulated value for heating (MVh)
CH1 Manipulated value for heating (MVh) for output with another analog module	407	0	Page 230 CH1 Manipulated value for heating (MVh) for output with another analog module

Buffer memory area name	Buffer memory address	Stored value	Reference
CH1 Manipulated value for cooling (MVC)	408	-50 (-5.0%)	Page 227 CH1 Manipulated value for cooling (MVC)
CH1 Manipulated value for cooling (MVC) for output with another analog module	409	0	Page 230 CH1 Manipulated value for cooling (MVC) for output with another analog module

Parameters related to control methods

The following table shows the parameters related to each control method.

Parameter	Setting range				
	Two-position control	P control	PD control	PI control	PID control
Input range setting	<ul style="list-style-type: none"> • Thermocouple: 1 to 4, 11 to 28, 36 to 52, 100 to 117, 130 to 132, 201 to 205 • Platinum resistance thermometer: 5 to 8, 53, 54, 140 to 143, 201 to 205 				
Set value (SV) setting	Set a value within the temperature measuring range of the set input range.				
Proportional band (P) setting, Cooling proportional band (Pc) setting (in the Q compatible mode)	Fix the setting to 0.	0 to 10000 (0.0% to 1000.0%)			
Integral time (I) setting (in the Q compatible mode)	A set value is ignored.	Fix the setting to 0.	1 to 3600 (s)		
Derivative time (D) setting (in the Q compatible mode)	A set value is ignored.	Fix the setting to 0.	1 to 3600 (s)	Fix the setting to 0.	1 to 3600 (s)
Adjustment sensitivity (dead band) setting	<ul style="list-style-type: none"> ■In the R mode 0 to Full scale (°C (°F)) ■In the Q compatible mode 0 to 10000 (0.0% to 1000.0%) 	A set value is ignored.			
Upper limit output limiter, lower limit output limiter (standard control only)	A set value is ignored.	-50 to 1050 (-5.0% to 105.0%)			
Upper limit output limiter, cooling upper limit output limiter (heating-cooling control only)	A set value is ignored.	0 to 1050 (0.0% to 105.0%)			
Output variation amount limiter	A set value is ignored.	1 to 1000 (1%/s to 100.0%/s)			
Control output cycle setting (standard control only)	A set value is ignored.	The setting range depends on the control output cycle unit selection setting. <ul style="list-style-type: none"> ■When the control output cycle unit selection setting is 1s cycle (0) <ul style="list-style-type: none"> • Setting range: 1 to 100 (s) • Default value: 30 (s) ■When the control output cycle unit selection setting is 0.1s cycle (1) <ul style="list-style-type: none"> • Setting range: 5 to 1000 (0.5 to 100.0s) • Default value: 300 (30.0s) 			
Control output cycle setting, cooling control output cycle setting (heating-cooling control only)	A set value is ignored.	The setting range depends on the control output cycle unit selection setting. <ul style="list-style-type: none"> ■When the control output cycle unit selection setting is 1s cycle (0) <ul style="list-style-type: none"> • Setting range: 1 to 100 (s) • Default value: 30 (s) ■When the control output cycle unit selection setting is 0.1s cycle (1) <ul style="list-style-type: none"> • Setting range: 5 to 1000 (0.5 to 100.0s) • Default value: 300 (30.0s) 			
Overlap/dead band setting	<ul style="list-style-type: none"> ■In the R mode (-(Full scale)) to Full scale (°C (°F)) ■In the Q compatible mode -100 to 100 (-10.0% to 10.0%) 	<ul style="list-style-type: none"> ■In the R mode (-(Full scale)) to Full scale (°C (°F)) ■In the Q compatible mode -100 to 100 (-10.0% to 10.0%) 			

Buffer memory areas related to control methods

The following table shows the buffer memory areas related to each control method.

Buffer memory area name	Buffer memory address	Setting range				
		Two-position control	P control	PD control	P control	PID control
CH1 Proportional band (P) setting, CH1 Heating proportional band (Ph) setting (in the R mode)	431	Fix the setting to 0.	0 to the full scale of the input range (°C (°F))			
CH1 Cooling proportional band (Pc) setting (in the R mode)	439					
CH1 Integral time (I) setting (in the R mode)	432	A set value is ignored.	Fix the setting to 0.		1 to 3600 (s)	
CH1 Derivative time (D) setting (in the R mode)	433	A set value is ignored.	Fix the setting to 0.	1 to 3600 (s)	A set value is ignored.	1 to 3600 (s)
CH1 Manual reset amount setting	517	A set value is ignored.	■ In the standard control or heating-cooling control <ul style="list-style-type: none"> • Setting range: -1000 to 1000 (-100.0% to 100.0%, in increments of 0.1%) • Default value: 0 (0%) 		A set value is ignored.	

Point

The temperature control module automatically sets optimum PID constants when the following functions are used.

- Auto Tuning Function ( Page 35 Auto Tuning Function)
- Self-Tuning Function ( Page 44 Self-tuning Function)

1.3 Sampling Cycle Switching Function

In the temperature control module, a measured temperature value is stored into 'CH1 Temperature process value (PV)' (Un\G402) every sampling cycle. In addition, the use of the primary delay digital filter smoothens the temperature process value (PV), and its drastic change can be absorbed.

Sampling cycle

Select 250ms or 500ms as a sampling cycle.

■How to set the sampling cycle

Configure the setting as follows.

 [Navigation window] ⇒ [Parameter] ⇒ Target module ⇒ [Module Parameter] ⇒ [Base Setting] ⇒ [Sampling cycle selection]

■How to check the sampling cycle

The sampling cycle in execution can be checked in 'Sampling cycle monitor' (Un\G38).

1.4 Control Output Cycle Unit Selection Function

This function is used to switch the unit for the control output cycle between 1s and 0.1s. When 0.1s is set as the control output cycle, more precise control can be executed.

The control output cycle is the ON/OFF cycle of transistor output for the temperature control function.

Setting method

Configure the setting as follows.

 [Navigation window] ⇒ [Parameter] ⇒ Target module ⇒ [Module Parameter] ⇒ [Base Setting] ⇒ [Control output cycle unit selection setting]

Point

- The setting range and default value of the control output cycle depends on this setting. ( Page 220 Control output cycle unit selection setting)
- A setting value discrepancy error (error code: 1920H) occurs right after changing this setting. To recover from the error status, turn on and off 'Set value backup instruction' (Y8). Then, register the new setting in the non-volatile memory.

1.5 HOLD/CLEAR Function

Whether to clear or hold the transistor output status when a CPU stop error occurs, a CPU module is turned from RUN to STOP, or the module becomes disconnected can be selected.

Standard control, heating-cooling control, mix control

The following shows the relation among the setting, error, and the operation of the CPU module.

Status		Processing			
HOLD/CLEAR setting		CLEAR		HOLD	
PID continuation flag		Stop	Continue	Stop	Continue
CPU module status	RUN	The temperature judgment and warning judgment are executed and the external output is executed.			
	Stop error	The temperature judgment and warning judgment stop and the external output is turned off.		The temperature judgment and warning judgment depend on the stop mode setting of "Control basic parameters" in "Application Setting" and the external output are turned off.	
Operation of the CPU module	RUN→STOP	The temperature judgment and warning judgment depend on the stop mode setting of "Control basic parameters" in "Application Setting" and the external output are turned off.		The temperature judgment and warning judgment depend on the stop mode setting of "Control basic parameters" in "Application Setting" and the external output are turned off.	
	Resetting	The module is inoperative, and does not execute external outputs.			
Disconnection*1		The temperature judgment and warning judgment depend on the stop mode setting of "Control basic parameters" in "Application Setting" and the external output are turned off.		The temperature judgment and warning judgment depend on the stop mode setting of "Control basic parameters" in "Application Setting" and the external output are turned off.	

*1 When the module is mounted together with a remote head module

Position proportional control

The following shows the relation among the setting, error, and the operation of the CPU module.

Status		Processing			
HOLD/CLEAR setting		CLEAR		HOLD	
PID continuation flag		Stop	Continue	Stop	Continue
CPU module status	RUN	The temperature judgment and warning judgment are executed and the external output is executed.			
	Stop error	The temperature judgment and warning judgment stop and the external output is turned off.		The temperature judgment and warning judgment depend on the stop mode setting of "Control basic parameters" in "Application Setting", and the external output depends on "Valve operation setting (When CPU stop)".	
Operation of the CPU module	RUN→STOP	The temperature judgment and warning judgment depend on the stop mode setting of "Control basic parameters" in "Application Setting", and the external output depends on "Valve operation setting (When CPU stop)".		The temperature judgment and warning judgment depend on the stop mode setting of "Control basic parameters" in "Application Setting", and the external output depends on "Valve operation setting (When CPU stop)".	
	Resetting	The module is inoperative, and does not execute external outputs.			
Disconnection*1		The temperature judgment and warning judgment depend on the stop mode setting of "Control basic parameters" in "Application Setting", and the external output depends on "Valve operation setting (When CPU stop)".		The temperature judgment and warning judgment depend on the stop mode setting of "Control basic parameters" in "Application Setting", and the external output depends on "Valve operation setting (When CPU stop)".	

*1 When the module is mounted together with a remote head module

Precautions

- Fully pay attention to the settings of "PID continuation Flag" of "Control basic parameters" in "Application Setting" and "Valve operation setting (When CPU stop)" of "Position-proportional control setting" in "Application Setting" for controlling external outputs.
- Depending on an output element failure or an internal circuit failure, an abnormal output may occur. Configure an external circuit for monitoring output signals that could cause a serious accident.

Setting method

Configure the setting as follows.

 [Navigation window] ⇒ [Parameter] ⇒ Target module ⇒ [Module Parameter] ⇒ [Base Setting] ⇒ [HOLD/CLEAR setting]

1.6 Overlap/dead Band Function

In the heating-cooling control, the temperature process value (PV) significantly changes due to a slight heating or cooling control output when the heat produced by a controlled object and natural cooling are being balanced. Consequently, an excessive output may be executed.

The temperature where the cooling control output starts can be shifted using this function; therefore, whether control stability is prioritized or energy saving is prioritized can be selected.

Overlap

The overlap refers to the temperature area where both of heating control and cooling control are executed. In the temperature area where both heating and cooling output overlap, both of the outputs negate each other. Thus, the control gain becomes moderate. Consequently, the variation amount in the temperature process value (PV) for the output becomes small, improving control stability.

Ex.

When the following values have been set:

- "Input range setting" of "Control basic parameters" in "Application Setting": 38 (Temperature measuring range: -200.0°C to 400.0°C)
- "Target Value(SV) Setting" of "Control basic parameters" in "Application Setting": 200.0°C
- "Overlap/dead band setting" of "Heating/cooling control setting" in "Application Setting": -15.0°C

The range of 185.0°C to 200.0°C is the overlapping area.

The temperature where a cooling operation starts = (Set value (SV)) - 15.0°C = 185.0°C

As shown below, shifting the temperature where a cooling operation starts to the lower temperature side of the set value (SV) produces an overlapping area. (The following is an example of when the module is in P control.)

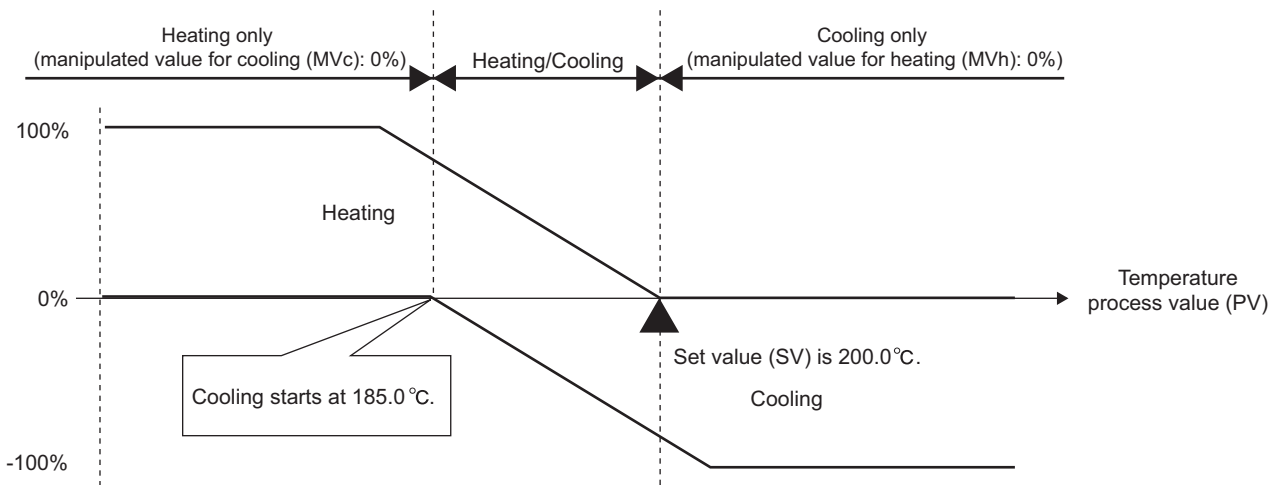

Point

In the Q compatible mode, set -2.5% for "Overlap/dead band setting" of "Heating/cooling control setting" in "Application Setting". $(400^{\circ}\text{C} - (-200^{\circ}\text{C})) \times (-0.025) = -15^{\circ}\text{C}$

Dead band

The dead band refers to the temperature area where neither heating control output nor cooling control output is executed. When the temperature process value (PV) is stable within this area, output is not executed for a slight change in the temperature, resulting in energy saving.

Ex.

When the following values have been set:

- "Input range setting" of "Control basic parameters" in "Application Setting": 38 (Temperature measuring range: -200.0°C to 400.0°C)
- "Target Value(SV) Setting" of "Control basic parameters" in "Application Setting": 200.0°C
- "Overlap/dead band setting" of "Heating/cooling control setting" in "Application Setting": 15.0°C

The range of 200.0°C to 215.0°C is the dead band area.

The temperature where a cooling operation starts = (Set value (SV)) + 15.0°C = 215.0°C

As shown below, shifting the temperature where a cooling operation starts to the lower temperature side of the set value (SV) produces a dead band area. (The following is an example of when the module is in P control.)

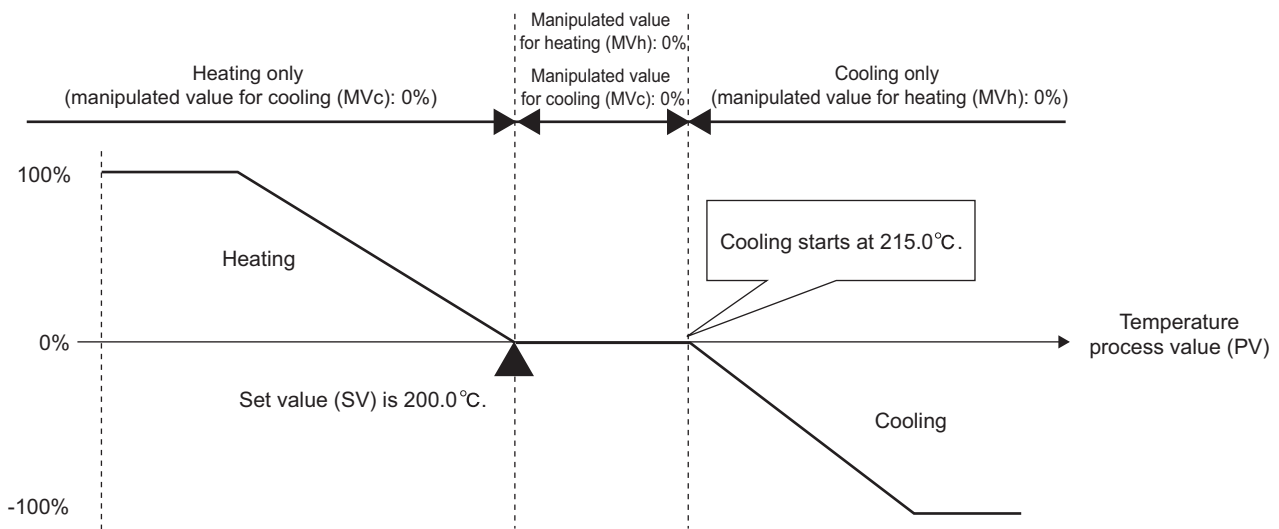

Point

In the Q compatible mode, set 2.5% for "Overlap/dead band setting" of "Heating/cooling control setting" in "Application Setting". $(400^{\circ}\text{C} - (-200^{\circ}\text{C})) \times 0.025 = 15^{\circ}\text{C}$

Dead band setting in the two-position control (three-position control)

Set the dead band in the two-position control.

Three-position control can be achieved by setting a dead band area in addition to areas for the manipulated value for heating (MVh) 100% and the manipulated value for cooling (MVC) 100%.

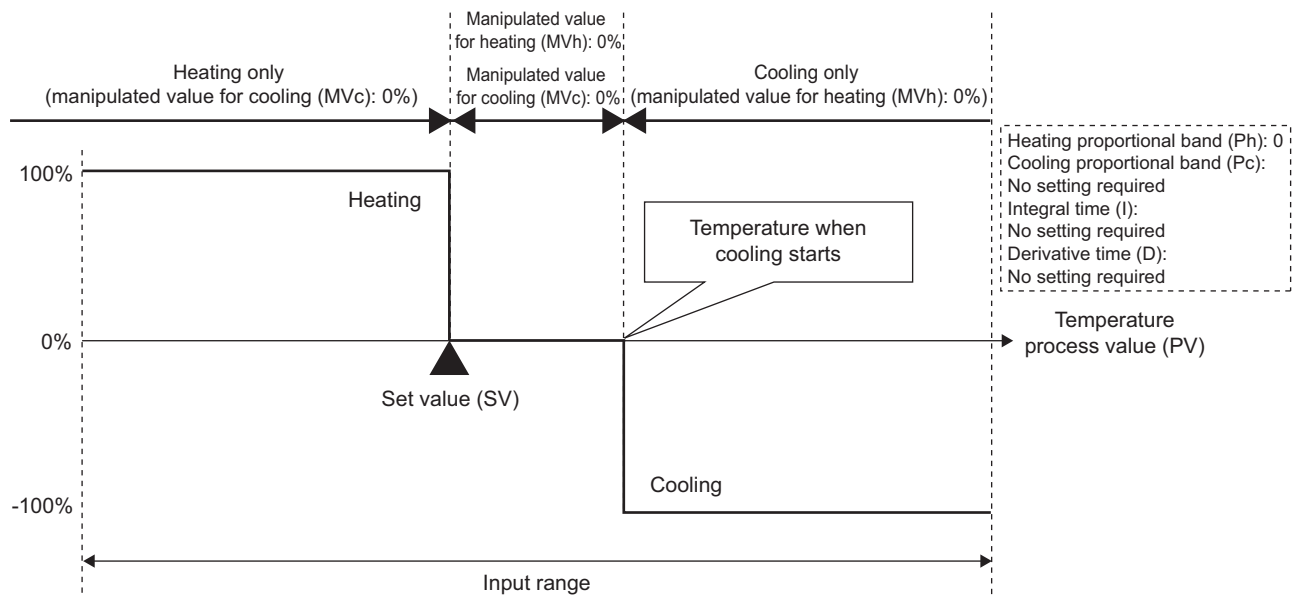

Setting method

Configure the setting as follows.

[Navigation window] ⇒ [Parameter] ⇒ Target module ⇒ [Module Parameter] ⇒ [Application Setting] ⇒ [Heating/cooling control setting] ⇒ [Overlap/dead band setting]

1.7 Manual Reset Function

This function is used to manually move a stable position in the P control or PD control.

An offset (remaining deviation) is manually reset by moving the proportional band (P).

The offset is reset by determining and setting the amount to shift the manipulated value (MV) in a stable condition from the reference value.

The reference value is 50% for the standard control, and 0% for the heating-cooling control.

Point

This function can be used only in the P control and PD control. This function is disabled when the integral time (I) is set to a value other than 0.

'CH1 Manual reset amount setting' (Un\G517) is ignored even though a value has been set. (However, when a value out of the setting value is set, an out of setting range error (error code: 1950H) occurs.)

Standard control

The set value (SV) is set at a point where the manipulated value (MV) is 50%. Thus, as long as the temperature process value (PV) and the set value (SV) are not balanced at 50% of the manipulated value (MV), an offset (remaining deviation) is generated.

When an offset is generated, the proportional band (P) can be manually shifted by the amount of the offset (remaining deviation).

Ex.

When using the manual reset function in the following conditions

- Control method: P control
- 'CH1 Manual reset amount setting' (Un\G517): 300 (30%)

The temperature control module shifts the manipulated value (MV) in a stable condition at the set value (SV) from 50% to 80%.

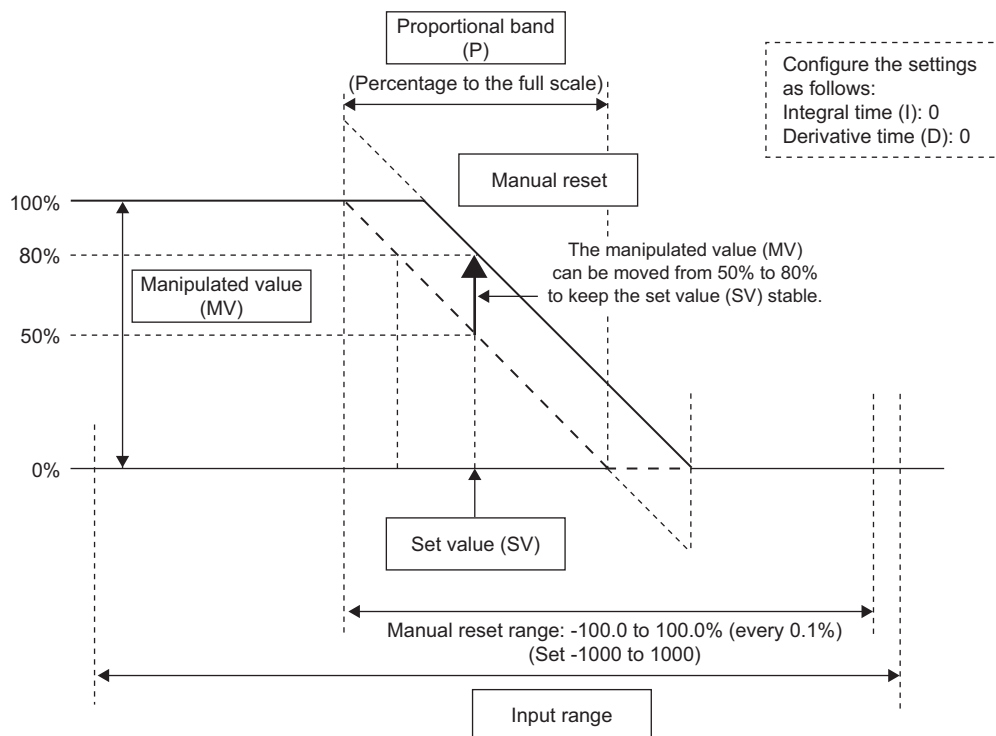

Heating-cooling control

The set value (SV) is set at a point where the manipulated value for heating (MVh)/manipulated value for cooling (MVc) is 0%. Thus, as long as the temperature process value (PV) and the set value (SV) are not balanced at 0% of the manipulated value for heating (MVh)/manipulated value for cooling (MVc), an offset (remaining deviation) is generated. When an offset is generated, the heating proportional band (Ph)/cooling proportional band (Pc) can be manually shifted by the amount of the offset (remaining deviation).

Ex.

When using the manual reset function in the following conditions

- Control method: P control
- 'CH1 Manual reset amount setting' (Un\G517): 800 (80%)

The temperature control module shifts the manipulated value (MV) in a stable condition at the set value (SV) from 0% to 80%.

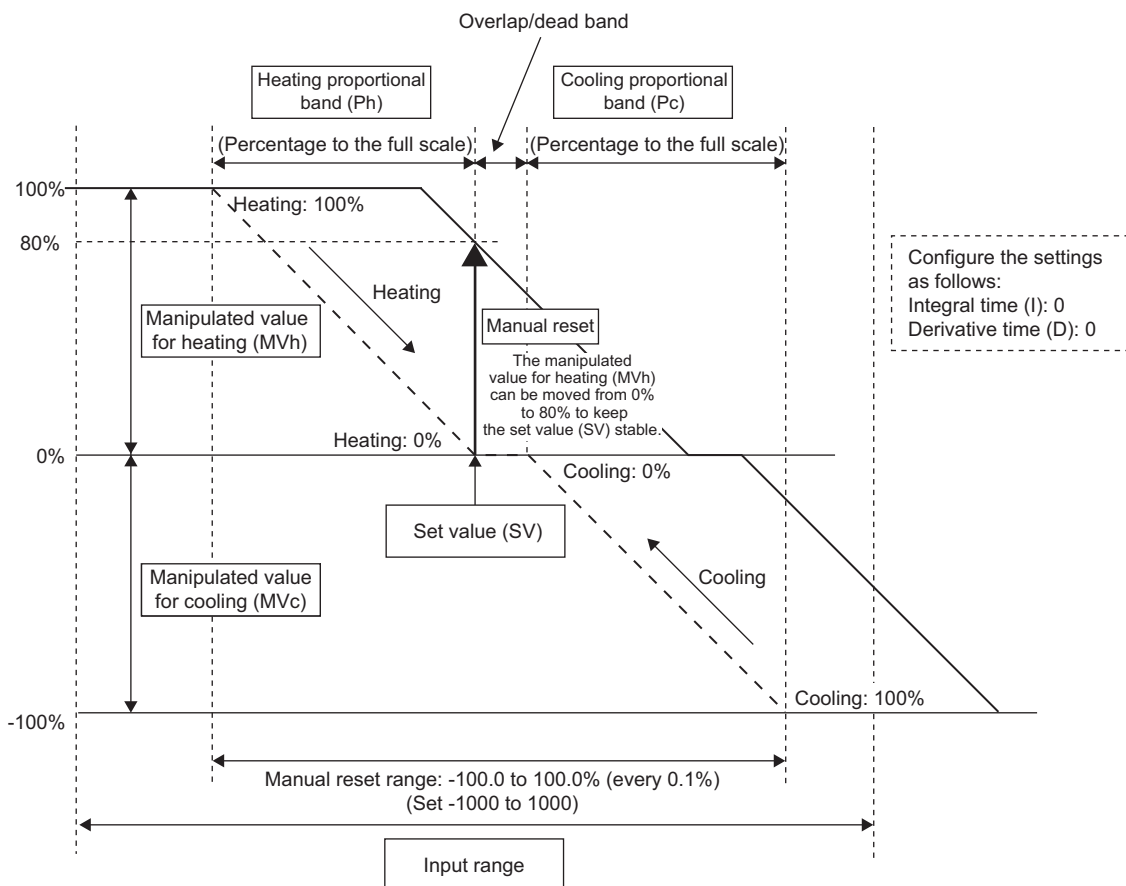

Setting method

Set a value in the following buffer memory area.

'CH1 Manual reset amount setting' (Un\G517) (📖 Page 263 CH1 Manual reset amount setting)

1.8 Cooling Method Setting Function

At the execution of auto tuning, an auto tuning operational expression is automatically selected depending on a selected cooling method and an operation is started.

Select one of the following methods:

- Air cooling: Select this method when cooling characteristics are a non-linear shape and cooling capacity is low.
- Water cooling: Select this method when cooling characteristics are a non-linear shape and cooling capacity is high.
- Linear: Select this method when cooling characteristics are close to a linear shape.

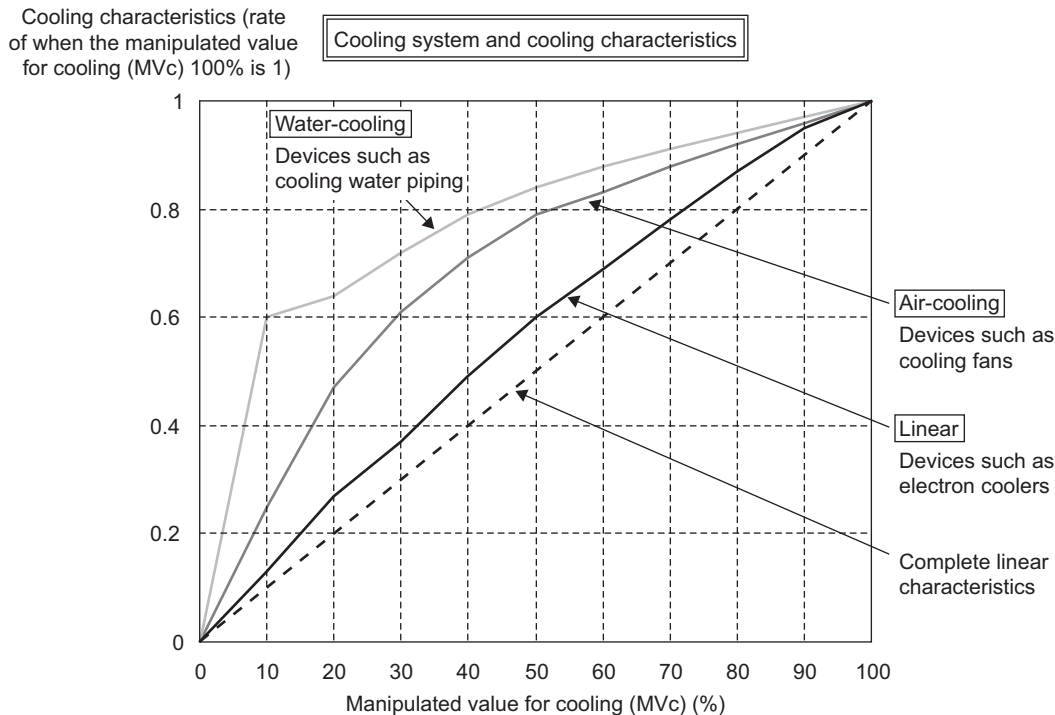

At the execution of the auto tuning, PID constants are calculated based on this setting and the auto tuning is executed. Therefore, more suitable PID constants can be calculated by the setting according to the cooling characteristics of the device. For details on the auto tuning function, refer to the following.

📖 Page 35 Auto Tuning Function

Setting method

Configure the setting as follows.

🔗 [Navigation window] ⇒ [Parameter] ⇒ Target module ⇒ [Module Parameter] ⇒ [Application Setting] ⇒ [Heating/cooling control setting] ⇒ [Cooling method setting]

Point

- An operational expression of the auto tuning for the calculation of PID constants is determined based on this setting. Thus, always configure this setting before the execution of the auto tuning.
- Air cooling and water cooling roughly indicate the level of the cooling ability. When a device is too cooled even though air cooling has been selected, set Water cooling (1H). When a device is less likely to be cooled even though water cooling has been selected, set Air cooling (0H).
- Generally, the ability of water cooling is higher than that of air cooling and cooling may be too strong when the same PID constants as the one for air cooling are used for water cooling. It takes time until the control becomes stable upon the first start-up, disturbance, or setting change. Therefore, the auto tuning calculates PID constants so that the PID constants of when Water cooling (1H) is set become larger than the ones of when Air cooling (0H) is set.

1.9 Temperature Conversion Function (Using Unused Channels)

In the heating-cooling control (normal mode), mix control (normal mode), or position proportional control (normal mode), only the temperature measurement can be executed using unused temperature input terminals. When this function is used, the temperature control and alert judgment are not executed.

Temperature input terminals that can be used

Temperature input terminals that can be used for this function differ depending on the control mode to be selected. Use the MT2□ (Monitor CH2), MT3□ (Monitor CH3), and MT4□ (Monitor CH4) terminals in the following table.

Terminal No.	Terminal symbol					
	When using thermocouples (R60TCTRT2TT2, R60TCTRT2TT2BW)			When using platinum resistance thermometers (R60TCTRT2TT2, R60TCTRT2TT2BW, R60TCRT4, R60TCRT4BW)		
	Heating-cooling control (normal mode)	Mix control (normal mode)	Position proportional control (normal mode)	Heating-cooling control (normal mode)	Mix control (normal mode)	Position proportional control (normal mode)
1	L1H	L1	CH1 OPEN	L1H	L1H	CH1 OPEN
2	L1C	L2	CH1 CLOSE	L1C	L1C	CH1 CLOSE
3	L2H	L3H	CH2 OPEN	L2H	L3	CH2 OPEN
4	L2C	L3C	CH2 CLOSE	L2C	L4	CH2 CLOSE
5	COM-	COM-	COM-	COM-	COM-	COM-
6	NC/CH2A	NC/MT2A	NC/CH2A	Not used	Not used	NC
7	CH1+/CH1B	CH1+/CH1B	CH1+/CH1B	CH1A	CH1A	CH1A
8	CH2+/CH2B	MT2+/MT2B	CH2+/CH2B	CH2A	MT2A	CH2A
9	CH1-/CH1b	CH1-/CH1b	CH1-/CH1b	CH1B	CH1B	CH1B
10	CH2-/CH2b	MT2-/MT2b	CH2-/CH2b	CH2B	MT2B	CH2B
11	NC/CH1A	NC/CH1A	NC/CH1A	CH1b	CH1b	CH1b
12	CJ	CJ	CJ	CH2b	MT2b	CH2b
13	NC	NC	NC	MT3A	CH3A	MT3A
14	CJ	CJ	CJ	MT4A	CH4A	MT4A
15	MT3+	CH3+	MT3+	MT3B	CH3B	MT3B
16	MT4+	CH4+	MT4+	MT4B	CH4B	MT3B
17	MT3-	CH3-	MT3-	MT3b	CH3b	MT3b
18	MT4-	CH4-	MT4-	MT4b	CH4b	MT4b

Parameters and buffer memory areas that can be used in this function

The following lists the parameters and buffer memory areas that can be used in this function.

Parameter

- "Input range setting" of "Control basic parameters" in "Application Setting"
- "Primary Delay Digital Filter Setting" in "Application Setting"
- "Sensor Correction Value Setting" in "Application Setting"
- "Number of moving averaging" in "Application Setting"
- "Temperature conversion setting" of "Heating/cooling control setting" in "Application Setting"
- "Cold Junction Temperature Compensation Selection" in "Application Setting" (the R60TCTRT2TT2 and R60TCTRT2TT2BW only)
- "Rate alarm alert output enable/disable setting" of "Rate alarm" in "Application Setting"
- "Rate alarm warning detection period" of "Rate alarm" in "Application Setting"
- "Rate alarm upper limit value" of "Rate alarm" in "Application Setting"
- "Rate alarm lower limit value" of "Rate alarm" in "Application Setting"

■ Buffer memory

Buffer memory area name	Buffer memory address		
	MT2(CH2)	MT3(CH3)	MT4(CH4)
Latest error code	0		
CH□ Decimal point position	600	800	1000
CH□ Alert definition	601	801	1001
CH1□ Temperature process value (PV)	602	802	1002
Cold junction temperature process value (the R60TCTRT2TT2 and R60TCTRT2TT2BW only)	45		
Control mode selection monitor	37		
CH□ Sensor two-point correction offset value (measured value)	768	968	1168
CH□ Sensor two-point correction offset value (corrected value)	769	969	1169
CH□ Sensor two-point correction gain value (measured value)	770	970	1170
CH□ Sensor two-point correction gain value (corrected value)	771	971	1171
CH□ Sensor two-point correction offset latch request	766	966	1166
CH□ Sensor two-point correction offset latch completion	619	819	1019
CH□ Sensor two-point correction gain latch request	767	967	1167
CH□ Sensor two-point correction gain latch completion	620	820	1020
Temperature conversion completion flag	43		

Setting method

Configure the setting as follows.

 [Navigation window] ⇒ [Parameter] ⇒ Target module ⇒ [Module Parameter] ⇒ [Application Setting] ⇒ [Heating/cooling control setting] ⇒ [Temperature conversion setting]

Point

When the heating-cooling control (expanded mode), mix control (expanded mode), or position-proportional control (expanded mode) has been selected, the setting of "Temperature conversion setting" is ignored.

1.10 Manual Control



A manipulated value (MV) can be set manually by users without being automatically calculated by the PID control. The manipulated value (MV) is checked every 250ms or 500ms and reflected to the transistor output.

Point

Select 250ms or 500ms in "Sampling cycle selection" of "Base Setting".

Setting method

Configure the setting by the following procedure.

1. Set 'CH1 AUTO/MAN mode shift' (Un\G518) to Manual (MAN) (1). ( Page 263 CH1 AUTO/MAN mode shift)
2. Check that MAN mode completed (1) has been stored in 'MAN mode shift completion flag' (Un\G44). ( Page 210 MAN mode shift completion flag)
3. Set the manipulated value (MV) in 'CH1 MAN output setting' (Un\G519). ( Page 264 CH1 MAN output setting)

Setting range

The setting range differs between the standard control and heating-cooling control.

- Standard control: -50 to 1050 (-5.0 to 105.0%)
- Heating-cooling control: -1050 to 1050 (-105.0 to 105.0%)

1.11 Auto Tuning Function

The temperature control module automatically sets the best PID constants. In the auto tuning, the control output is turned on and off, and PID constants are calculated depending on the hunting cycle and amplitude that occur when overshoots and undershoots of the temperature process value (PV) to the set value (SV) are repeated.

Auto tuning operation

The temperature control module operates as follows.

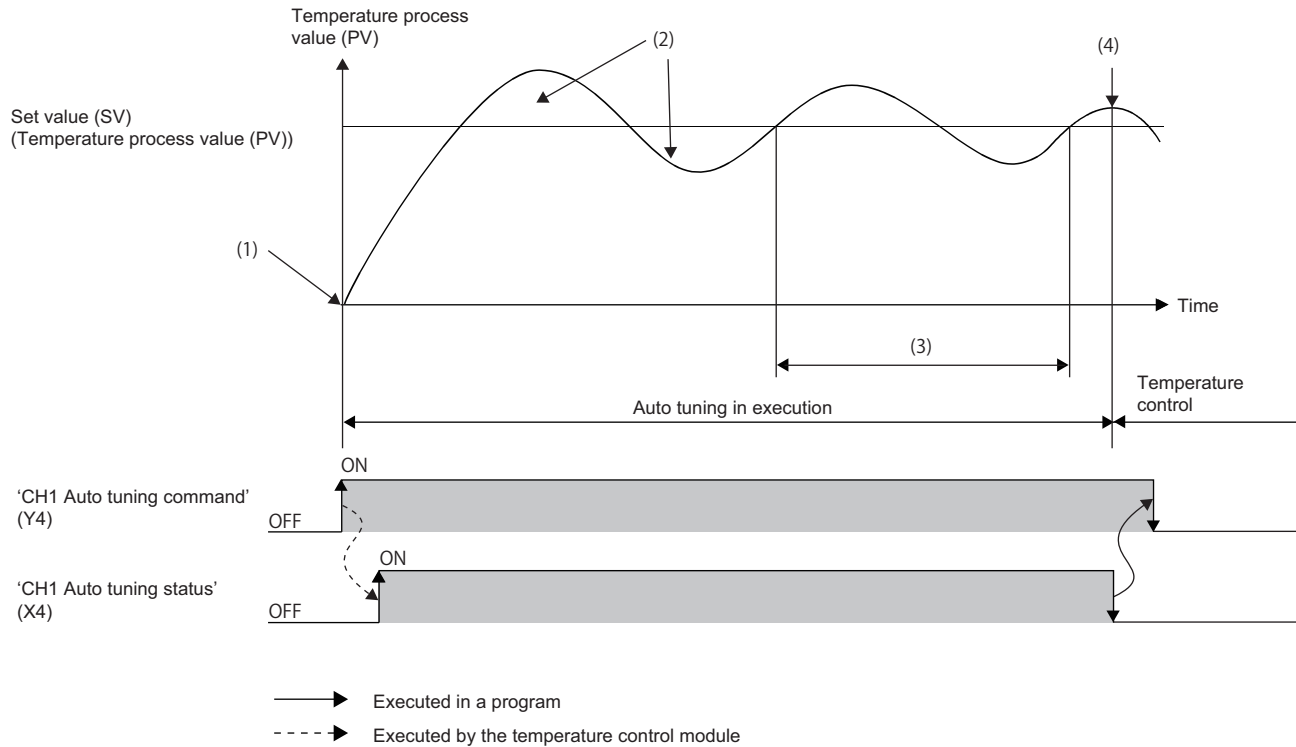

- (1) The module starts the auto tuning.
- (2) The first overshoot and undershoot are ignored.
- (3) The module collects data from the point where the temperature process value (PV) reaches the set value (SV) after the first overshoot and undershoot.
- (4) The module ends the auto tuning when PID constants and the loop disconnection detection judgment time are set after the data collection.

Point

The time taken for the auto tuning depends on a controlled object.

Settings related to the auto tuning

The auto tuning can be executed when the following setting have been configured. Configure the other settings to the values used for actual operations because actual control starts on completion of the auto tuning.

When "0" has been set for 'CH1 Proportional band (P) setting' (Un\G431) or 'CH1 Heating proportional band (Ph) setting' (Un\G431), auto tuning is not executed.

- "Input range setting" of "Control basic parameters" in "Application Setting"
- "Target Value(SV) Setting" of "Control basic parameters" in "Application Setting"
- "Upper limit output limiter" of "Limiter setting" in "Application Setting"
- "Lower limit output limiter" of "Limiter setting" in "Application Setting"
- "Cooling upper limit output limiter" of "Heating/cooling control setting" in "Application Setting"
- "Output Change Amount Limiter" of "Limiter setting" in "Application Setting"
- "Sensor Correction Value Setting" in "Application Setting"
- "Control output cycle setting" of "Control basic parameters" in "Application Setting"
- "Cooling control output cycle setting" of "Heating/cooling control setting" in "Application Setting"
- "Primary Delay Digital Filter Setting" in "Application Setting"
- 'CH1 AUTO/MAN mode shift' (Un\G518)
- "AT Bias" of "Auto tuning setting" in "Application Setting"
- "Normal Operation/Reverse Operation Setting" in "Application Setting"
- "Auto tuning mode setting" of "Auto tuning setting" in "Application Setting"

Point

For the system in which a temperature quickly rises, set the upper limit output limiter. Set a value twice as large as the manipulated value (MV) in a stable state as a guide. After the completion of the auto tuning, the output limiter can be returned to its initial value to start the control.

Storing the calculation values after auto tuning

After the completion of the auto tuning, calculation values are stored into the following buffer memory areas.

- 'CH1 Proportional band (P) setting' (Un\G431)
- 'CH1 Heating proportional band (Ph) setting' (Un\G431)
- 'CH1 Cooling proportional band (Pc) setting' (Un\G439)
- 'CH1 Integral time (I) setting' (Un\G432)
- 'CH1 Derivative time (D) setting' (Un\G433)
- 'CH1 Loop disconnection detection judgment time' (Un\G537)*¹

*¹ A value that is twice as large as the value in 'CH1 Integral time (I) setting' (Un\G432) is automatically set. However, when this setting has been set to 0s at the auto tuning, the loop disconnection detection judgment time is not stored.

Backing up calculation values at the completion of the auto tuning



When the following setting has been configured to "Valid" at the start of the auto tuning, values are automatically backed up in the non-volatile memory.

 [Navigation window] ⇒ [Parameter] ⇒ [Module Information] ⇒ Target module ⇒ [Application Setting] ⇒ [Auto tuning setting] ⇒ [Automatic backup setting after auto tuning of PID constants]

To read the calculation value from the non-volatile memory to the buffer memory, set 'CH1 Memory's PID constants read command' (Un\G440) to Requested (1). ( Page 244 CH1 Memory's PID constants read command)

Point

To use the PID constants stored in the buffer memory in the Q compatible mode even after power-off, follow the methods below.

- Use the initial setting of the engineering tool. ( Page 131 PARAMETER SETTING)
- Store the PID constants in the non-volatile memory, and transfer them when the power is turned off and on or when the CPU module is reset and the reset is cleared. ( Page 119 Buffer Memory Data Backup Function)
- Write the values directly into the buffer memory using a program.

Precautions

When the auto tuning is executed with the engineering tool, the memory having the capacity of 700MB or larger is required. Check the memory that can be used has the capacity of 700MB or larger and execute the auto tuning.

Procedure of auto tuning

■When using the engineering tool

[Tool] ⇒ [Module Tool List]

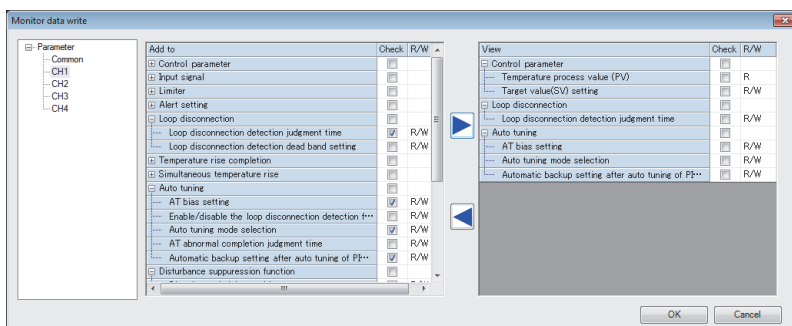
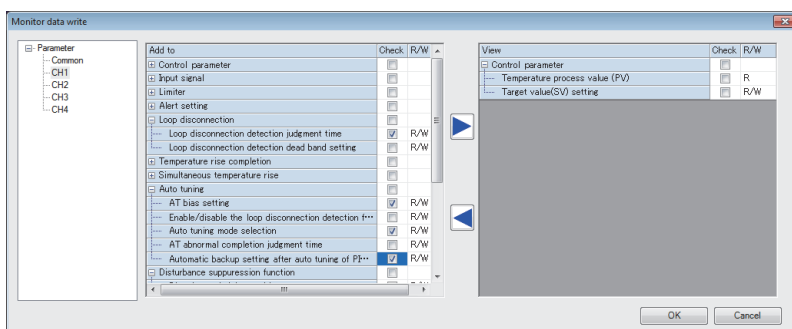
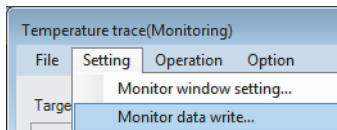
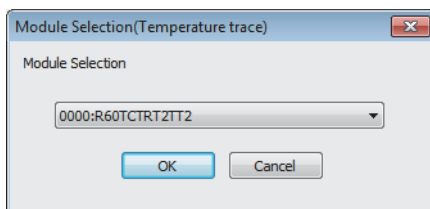
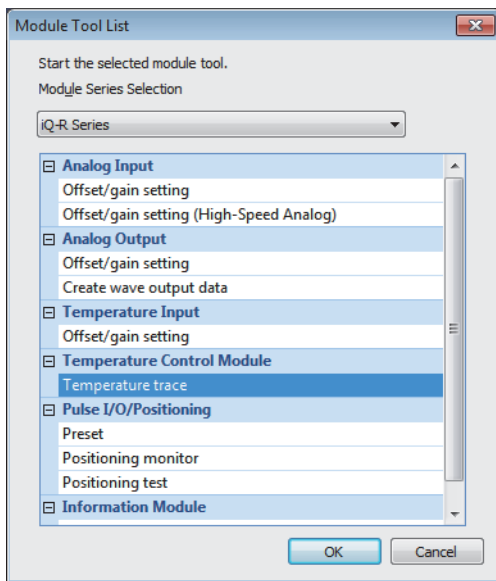

1. Select "Temperature trace" of "Temperature Control Module" and click the [OK] button.

2. Select the module to configure the temperature control setting and click the [OK] button.

3. Select "Monitor data write" from the following.

[Setting] ⇒ [Monitor data write]

4. Select the parameter to be changed from "Add to" to click the ► button.

5. The parameter is added in "View".

6. Click the [OK] button.

Name	Color	Value
Parameter		
CH1Temperature process value (PV)	■	0°C
CH2Temperature process value (PV)	■	0°C
CH3Temperature process value (PV)	■	0°C
CH4Temperature process value (PV)	■	0°C
CH1Target value(SV) setting	■	50°C
CH2Target value(SV) setting	■	0°C
CH3Target value(SV) setting	■	0°C
CH4Target value(SV) setting	■	0°C
CH1Loop disconnection detection judgment time		480s
CH1AT bias setting	■	0°C
CH1Auto tuning mode selection	■	0:Standard mode
CH1Automatic backup setting after auto tuning c	■	1:ON

Name	CH1	CH2	CH3	CH4
Control command				
Setting/Operation mode command	1:Operation mode command			
Setting/Operation mode status	1:Operation mode			
Auto tuning command	1:ON	0:OFF	0:OFF	0:OFF
Auto tuning status	Stopped	Stopped	Stopped	Stopped
PID control force stop command	0:OFF	0:OFF	0:OFF	0:OFF
Setting value back up command	0:OFF			
Setting value back up completed fla	0:OFF			
Forced feed forward control starting	0:OFF	0:OFF	0:OFF	0:OFF
Forced feed forward control starting	0:OFF	0:OFF	0:OFF	0:OFF
AUTO/MAN mode shift	0:AUTO	0:AUTO	0:AUTO	0:AUTO

Name	CH1	CH2	CH3	CH4
Control command				
Setting/Operation mode command	1:Operation mode command			
Setting/Operation mode status	1:Operation mode			
Auto tuning command	1:ON	0:OFF	0:OFF	0:OFF
Auto tuning status	Executing	Stopped	Stopped	Stopped
PID control force stop command	0:OFF	0:OFF	0:OFF	0:OFF
Setting value back up command	0:OFF			
Setting value back up completed fla	0:OFF			
Forced feed forward control starting	0:OFF	0:OFF	0:OFF	0:OFF
Forced feed forward control starting	0:OFF	0:OFF	0:OFF	0:OFF
AUTO/MAN mode shift	0:AUTO	0:AUTO	0:AUTO	0:AUTO

7. Write the set value to be changed.

8. Set "Setting/Operation mode command" to "1: Operation mode command".

9. Set "Auto tuning command" to "1: ON".

10. When "Auto tuning command" is set to "1: ON", "Auto tuning status" becomes "Executing" and the auto tuning starts.

11. When the auto tuning is completed, "Auto tuning status" becomes "Stopped".

12. The temperature control is executed with the set PID constants.

■When using a program

The auto tuning is executed by the following procedure.

1. Setting each data in the temperature control module

Set each data. (☞ Page 36 Settings related to the auto tuning)

2. Operation mode setting

- Turn off and on 'Setting/operation mode command' (Y1). (☞ Page 158 Setting/operation mode command)
- Check that 'Setting/operation mode status' (X1) is on. (☞ Page 151 Setting/operation mode status)

3. Starting the auto tuning

Turn off and on 'CH1 Auto tuning command' (Y4). (☞ Page 158 Auto tuning command)

4. During auto tuning

'CH1 Auto tuning status' (X4) is on. (☞ Page 153 Auto tuning status)

5. After the completion of the auto tuning (setting PID constants)

'CH1 Auto tuning status' (X4) turns off and calculation values are set in the buffer memory. (☞ Page 36 Storing the calculation values after auto tuning)

6. Temperature control with the set PID constants

The temperature control is executed with the set PID constants.

Conditions in which the auto tuning cannot be executed

When one of the following conditions is satisfied, the auto tuning cannot be executed.

Condition	
1	The module is in the setting mode ('Setting/operation mode status' (X1): Off).
2	■In the R mode In the standard control or heating-cooling control, 0 (0°C (°F)) has been set for 'CH1 Proportional band (P) setting' (Un\G431) and 'CH1 Heating proportional band (Ph) setting' (Un\G431). (The two-position control has been applied.) ■In the Q compatible mode In the standard control or heating-cooling control, 0% has been set for "Proportion Belt (P) Setting" of "Control basic parameters" in "Application Setting". (The two-position control has been applied.)
3	'CH1 AUTO/MAN mode shift' (Un\G518) has been set to MAN (1).
4	"Unused" has been set for the corresponding channels in "Unused channel setting" of "Control basic parameters" in "Application Setting".
5	'CH1 PID control forced stop command' (YC) is on.
6	A hardware failure has occurred. (The ERR LED is on.)
7	The value in 'CH1 Temperature process value (PV)' (Un\G402) has exceeded the temperature measuring range. (CH1 Input range upper limit (Un\G401, b0) or CH1 Input range lower limit (Un\G401, b1) is on.)
8	'CH1 Memory's PID constants read command' (Un\G440) has been set to Requested (1).
9	CH1 Write completion flag (Un\G47, b0) is on.
10	The set value (SV) or the AT point is out of the range set in "Upper Limit Setting Limiter" and "Lower Limit Setting Limiter" of "Limiter setting" in "Application Setting".

■When one of the conditions 1 to 5 is satisfied

The auto tuning starts when the condition is cleared.

■When the condition 7 is satisfied

Even though the temperature process value (PV) goes back within the temperature measuring range, the auto tuning does not start until 'CH1 Auto tuning command' (Y4) is turned off and on again.

■When the condition 8 or 9 is satisfied

Even though the internal processing of the auto tuning is completed and PID constants are stored, 'CH1 Auto tuning status' (X4) does not turn off and the auto tuning is not completed.

■When the condition 10 is satisfied

Even though the set value (SV) or the AT point goes back within the range set in "Upper Limit Setting Limiter" and "Lower Limit Setting Limiter" of "Limiter setting" in "Application Setting", auto tuning does not start until 'CH1 Auto tuning command' (Y4) is turned off and on again.

Conditions in which the auto tuning ends in failure

The following shows the conditions.

■Shifting from the operation mode to the setting mode

When the mode is shifted from the operation mode to the setting mode ('Setting/operation mode command' (Y1) is turned on and off), the auto tuning ends in failure. Note that an exception is when "Continue" has been set for "PID continuation Flag" of "Control basic parameters" in "Application Setting".

■Setting change during auto tuning

When the following settings are changed during auto tuning, the auto tuning ends in failure.

- "Target Value(SV) Setting" of "Control basic parameters" in "Application Setting"
- "Upper limit output limiter" of "Limiter setting" in "Application Setting"
- "Lower limit output limiter" of "Limiter setting" in "Application Setting"
- "Cooling upper limit output limiter" of "Heating/cooling control setting" in "Application Setting"
- "Sensor Correction Value Setting" in "Application Setting"
- "Control output cycle setting" of "Control basic parameters" in "Application Setting"
- "Cooling control output cycle setting" of "Heating/cooling control setting" in "Application Setting"
- "Primary Delay Digital Filter Setting" in "Application Setting"
- 'CH1 AUTO/MAN mode shift' (Un\G518)
- "AT Bias" of "Auto tuning setting" in "Application Setting"
- "Normal Operation/Reverse Operation Setting" in "Application Setting"
- "Unused channel setting" of "Control basic parameters" in "Application Setting"
- "Cold Junction Temperature Compensation Selection" in "Application Setting"
- "Output Change Amount Limiter" of "Limiter setting" in "Application Setting"
- "Auto tuning mode setting" of "Auto tuning setting" in "Application Setting"

■Out of the temperature measuring range

If CH1 Temperature process value (PV) (Un\G402) exceeds the temperature measuring range (CH1 Input range upper limit (Un\G401, b0) or CH1 Input range lower limit (Un\G401, b1) is on), the auto tuning ends in failure.

■Time for the temperature process value (PV) to reach the set value (SV) for the first time or a half cycle of the hunting of the temperature process value (PV)

When the following time exceeds the value set for "Auto tuning forced termination time setting" of "Auto tuning setting" in "Application Setting", the auto tuning ends in failure.

- Time from the start of the auto tuning until 'CH1 Temperature process value (PV)' (Un\G402) reaches the set value (SV) for the first time
- A half cycle of the hunting of 'CH1 Temperature process value (PV)' (Un\G402)

■Calculation value of PID constants after auto tuning (in the R mode)

When a calculation value of PID constants after auto tuning exceeds one of the following ranges, the auto tuning ends in failure.

- 'CH1 Proportional band (P) setting' (Un\G431): 0.1 to the full scale of the input range (°C (°F))
- 'CH1 Integral time (I) setting' (Un\G432): 1 to 3600 (s)
- 'CH1 Derivative time (D) setting' (Un\G433): 0 to 3600 (s)

■ Calculation value of PID constants after auto tuning (in the Q compatible mode)

When a calculation value of PID constants after auto tuning exceeds one of the following ranges, the auto tuning ends in failure.

- "Proportion Belt (P) Setting" of "Control basic parameters" in "Application Setting": 0.1 to 1000.0%
- "Integration Time (I) Setting" of "Control basic parameters" in "Application Setting": 1 to 3600s
- "Differentiation Time (D) Setting" of "Control basic parameters" in "Application Setting": 0 to 3600s

Point

When the auto tuning ends in failure due to the calculation value of PID constants as described above, check the system configuration. (Select a suitable heater capacity or others.)

When temperature control points are close between channels, the auto tuning may not be completed due to a heat interruption if the auto tuning is executed to all channels in a batch. In this case, execute the auto tuning by one channel to prevent from receiving heat interruptions.

■ Change of the upper limit setting limiter or lower limit setting limiter and AT point

When the AT point goes out of the setting range due to a change in one of the following parameters, the auto tuning ends in failure.

- "Upper Limit Setting Limiter" of "Limiter setting" in "Application Setting"
- "Lower Limit Setting Limiter" of "Limiter setting" in "Application Setting"

■ Other conditions (in the R mode)

In addition to the conditions described above, if any of the following conditions is satisfied, the auto tuning ends in failure.

- 'CH1 PID control forced stop command' (YC) has been turned off and on.
- A hardware failure has occurred.
- In the standard control, 'CH1 Proportional band (P) setting' (Un\G431) has been set to 0 (0°C (°F)). (The two-position control has been set.)
- In the heating-cooling control, 'CH1 Heating proportional band (Ph) setting' (Un\G431) has been set to 0 (0°C (°F)). (The two-position control has been set.)

■ Other conditions (in the Q compatible mode)

In addition to the conditions described above, if any of the following conditions is satisfied, the auto tuning ends in failure.

- 'CH1 PID control forced stop command' (YC) has been turned off and on.
- A hardware failure has occurred.
- In the standard control or heating-cooling control, 0% has been set for "Proportion Belt (P) Setting" of "Control basic parameters" in "Application Setting". (The two-position control has been set.)

Actions after the completion of the auto tuning

■When the auto tuning ends properly

The temperature control module operates as follows.

- 'CH1 Auto tuning status' (X4) turns off.
- Set the PID constants.
- Set "Loop disconnection detection judgment time" of "Loop disconnection detection setting" in "Application Setting". (When 0 (s) has been set before the start of the auto tuning, no value is stored. (The value is not changed from 0.))

■When the auto tuning ends in failure

The temperature control module operates as follows.

- An auto tuning error occurs.
- 'CH1 Auto tuning status' (X4) turns off.
- The PID constants are not set.

Checking the completion of the auto tuning

The completion of the auto tuning can be checked by turning on and off 'CH1 Auto tuning status' (X4).

Adjustment after auto tuning

To change the control response for the PID constants calculated by the auto tuning, change the setting in the following parameter.

- "Control Response Parameters" of "Control basic parameters" in "Application Setting"

Point

In the system where a temperature rises rapidly, the auto tuning may not be executed properly due to the excessive temperature rise during the auto tuning. Create a program that executes the auto tuning in combination with the alert function that stops the auto tuning when an alert occurs during the auto tuning.

During AT loop disconnection detection function

For details on the during AT loop disconnection detection function, refer to the following.

 Page 90 During AT Loop Disconnection Detection Function

1.12 Self-tuning Function

The temperature control module constantly monitors the control state. When the control system is oscillatory just after the control start, owing to the set value (SV) change or fluctuation of characteristics of a controlled object, this function allows PID constants to be automatically changed. Unlike the auto tuning function, a response waveform observation is monitored and PID constants are automatically calculated and set. This function facilitates an object to be controlled with the most suitable PID constants all the time without disturbance.

Differences between auto tuning and self-tuning

The following table lists the differences between auto tuning and self-tuning.

Item	Auto tuning	Self-tuning
Calculation of PID constants	The manipulated value (MV) is turned on or off and PID constants are calculated based on the hunting cycle and amplitude of the temperature process value (PV) to the set value (SV).	PID constants are calculated based on the oscillation that occurred in some situations such as after the control has just started, the set value (SV) has been changed, and when a control response is oscillatory.
Execution method	Turning off and on 'CH1 Auto tuning command' (Y4) starts the auto tuning and changes PID constants upon completion.	The temperature control module constantly monitors the control response. PID constants are calculated and changed when the control response is slow.
Control response	PID constants are calculated based on the control response of when the manipulated value (MV) is turned on or off. Therefore, the control may become unstable.	PID constants are calculated based on the control response of the temperature control in execution. Therefore, the control is stable.
Calculation result	The optimum PID constants are calculated by one tuning. In the standard control, the loop disconnection detection judgment time is also calculated.	The optimum PID constants may not be obtained by one tuning. The loop disconnection detection judgment time is not calculated.
PID constants setting when characteristics of a controlled object change	Users need to execute the auto tuning again to change PID constants.	The temperature control module automatically changes the PID constants.
Available control mode	Standard control, heating-cooling control, or position-proportional control	Standard control only

Starting ST and vibration ST

Depending on the control system status, the following two types of self-tuning (ST) can be used: Starting ST and vibration ST

- Starting ST: Self-tuning is executed immediately after the control is started or when the set value (SV) is changed.
- Vibration ST: Self-tuning is executed when the control system in a stable state has become oscillatory due to some causes such as disturbance.

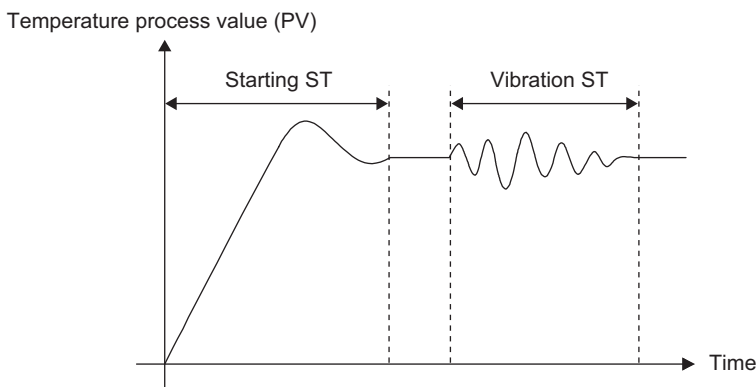

How to set starting ST

Set one of the following values for "Self-tuning setting" in "Application Setting". (The default value is "0:Do Not Run the ST".)

- 1: Starting ST (PID constant only)
- 2: Starting ST (Simultaneous temperature rise parameter only)
- 3: Starting ST (PID Constant and simultaneous temperature rise parameter)
- 4: Starting ST plus Vibration (PID Constant Only)

■How to set vibration ST





Set the following value for "Self-tuning setting" in "Application Setting".

- 4:Starting ST plus Vibration (PID Constant Only)





Operation of self-tuning

The following shows the operations after the start of the self-tuning.

■When the temperature control is started or the set value (SV) is changed

1. 'CH1 Auto tuning status' (X4) is on. (Starting ST) ( Page 153 Auto tuning status)
2. CH1 PID auto-correction status (Un\G411, b0) is turned off. ( Page 231 CH1 Self-tuning flag)
3. The temperature is controlled using the set PID constants.
4. PID constants are calculated by the self-tuning.
5. Check if the control response is poor or not.
If not, proceed to No. 8.
6. The PID constants are changed to the ones calculated by the self-tuning.
7. CH1 PID auto-correction status (Un\G411, b0) is turned on. ( Page 231 CH1 Self-tuning flag)
8. 'CH1 Auto tuning status' (X4) turns off. ( Page 153 Auto tuning status)
9. The temperature is controlled with the set PID constants.



■When the temperature control is not started or the set value (SV) is not changed

1. Check if the temperature process value (PV) is out of the set value (SV) or not.
If not, proceed to No. 8.
2. Check if the control response is oscillatory or not.
If not, proceed to No. 8.
3. 'CH1 Auto tuning status' (X4) is on. (Vibration ST) ( Page 153 Auto tuning status)
4. CH1 PID auto-correction status (Un\G411, b0) is turned off. ( Page 231 CH1 Self-tuning flag)
5. PID constants are calculated and changed by the self-tuning.
6. CH1 PID auto-correction status (Un\G411, b0) is turned on. ( Page 231 CH1 Self-tuning flag)
7. 'CH1 Auto tuning status' (X4) turns off. ( Page 153 Auto tuning status)
8. The temperature is controlled with the set PID constants.

Operation with starting ST

This section describes the operation when the temperature control is started or the set value (SV) is changed (starting ST). With starting ST, the module monitors the response waveform of the temperature process value (PV) of when the temperature control is started or when the set value (SV) is changed, and automatically corrects PID constants.

The following describes the operations of the module with starting ST.

1. CH1 PID auto-correction status (Un\G411, b0) is turned off. 'CH1 Auto tuning status' (X4) turns on. ( Page 231 CH1 Self-tuning flag, Page 153 Auto tuning status)
2. The temperature is controlled using the set PID constants.
3. When a control response is poor, PID constants are calculated based on the response waveform and are set in the buffer memory. CH1 PID auto-correction status (Un\G411, b0) is turned on. When a control response is good, CH1 PID auto-correction status (Un\G411, b0) keeps off and the PID constants are not changed. ( Page 231 CH1 Self-tuning flag)
4. 'CH1 Auto tuning status' (X4) turns off. ( Page 153 Auto tuning status)

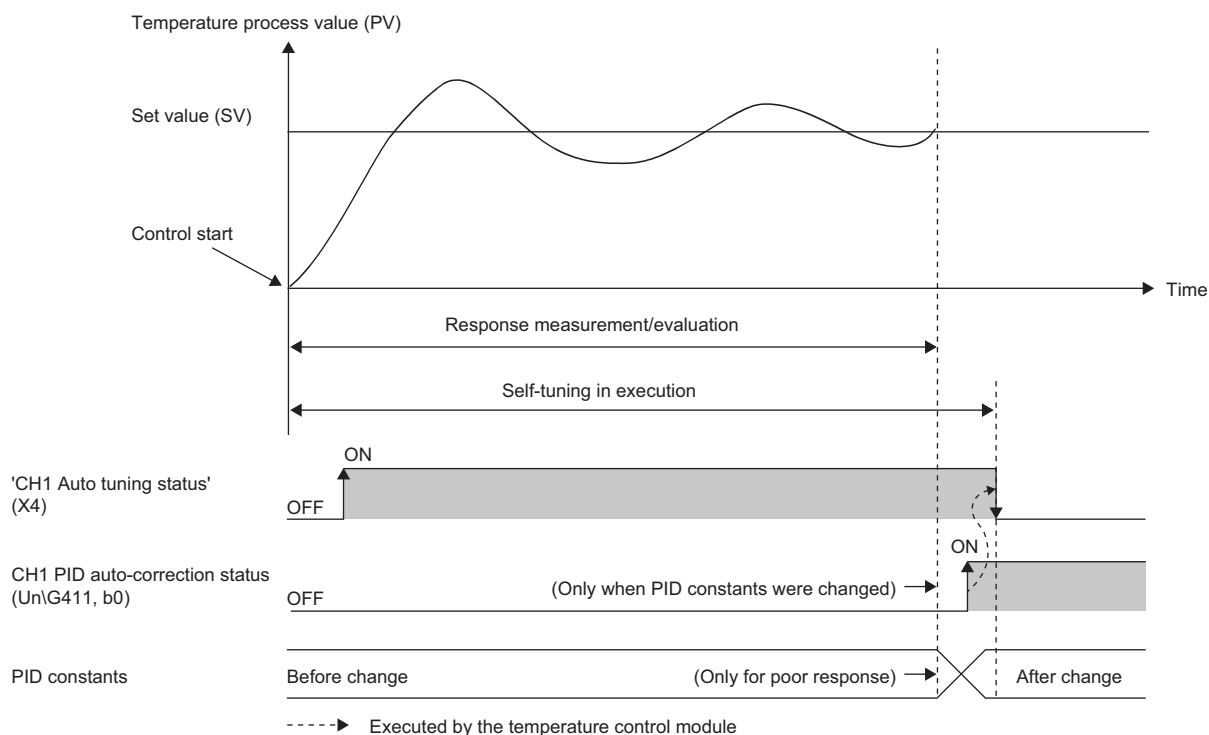

Conditions for execution

Starting ST is executed under the following conditions.

- When the mode is shifted from the setting mode to the operation mode ('Setting/operation mode command' (Y1) is turned off and on) for the first time after the power is turned off and on or after the CPU module is reset and the reset is cleared
- When the mode is shifted from the setting mode to the operation mode for the second time or later after the power is turned off and on or after the CPU module is reset and the reset is cleared (only when the temperature process value (PV) has been stable for two minutes or longer before the mode is shifted)
- When the set value (SV) is changed (only when the temperature process value (PV) before a change of the set value (SV) has been stable for two minutes or longer)

Point

When the starting ST is started when the temperature process value (PV) has not been stable, incorrect PID constants may be calculated. Execute the starting ST after the temperature process value (PV) has been stable for two minutes or longer.

Operation with vibration ST

This section describes the operation of when a control response is oscillatory (vibration ST).

With vibration ST, PID constants are automatically corrected to settle a vibration when a control response becomes oscillatory due to some causes such as the change of the characteristics of a controlled object and operation conditions.

The following describes the operations of the module with vibration ST. (The listed operations are under the state where the temperature is being controlled with the set PID constants.)

1. CH1 PID auto-correction status (Un\G411, b0) is turned off. 'CH1 Auto tuning status' (X4) turns on. (Page 231 CH1 Self-tuning flag, Page 153 Auto tuning status)
2. PID constants are calculated based on a response waveform.
3. When a control response is poor, PID constants are calculated based on the response waveform and are set in the buffer memory. CH1 PID auto-correction status (Un\G411, b0) is turned on. When a control response is good, CH1 PID auto-correction status (Un\G411, b0) keeps off and the PID constants are not changed. (Page 231 CH1 Self-tuning flag)
4. 'CH1 Auto tuning status' (X4) turns off. (Page 153 Auto tuning status)

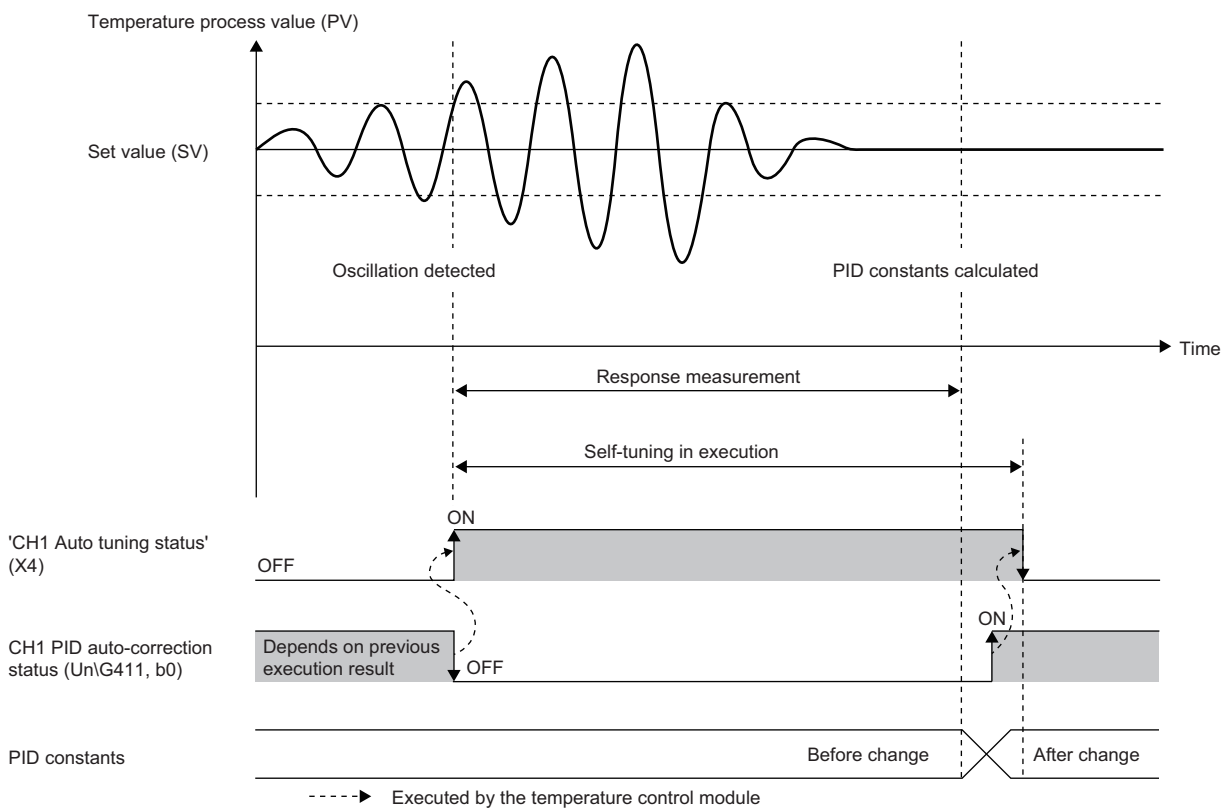

■Conditions for execution

When the temperature process value (PV) is out of the range considered as stable, vibration ST is executed.

■Precautions

When vibration ST is executed to the following controlled objects, inappropriate PID constants may be calculated.

- Controlled objects where a disturbance periodically occurs
- Controlled objects with strong mutual interference

Conditions in which the self-tuning is not executed

The following lists the conditions.

■When the control method is other than PID control

When a control method other than PID control (two-position control, P control, PI control, or PD control) is selected, the self-tuning is not executed. CH1 Self-tuning disable status (Un\G411, b8) is turned on. When all PID constants of the target channels turn to a value other than 0, the self-tuning is enabled.

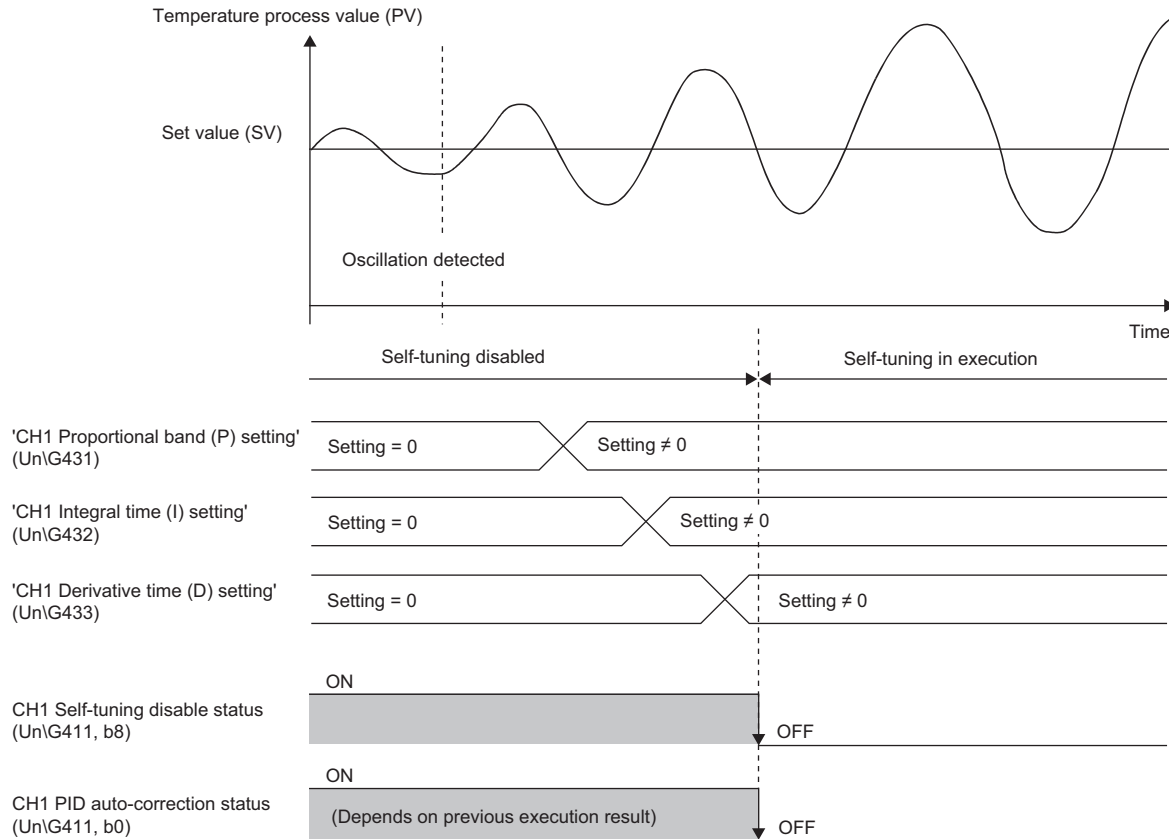

■While the auto tuning is being executed

While the auto tuning is being executed, the self-tuning is not executed. At this time, an error does not occur. When the auto tuning is completed, the self-tuning is enabled.

■The lower limit output limiter value is smaller than the manipulated value (MV) and the manipulated value (MV) is smaller than the upper limit output limiter value when the temperature control is started or the set value (SV) is changed

The starting ST does not start. However, when the following setting has been configured, the self-tuning is enabled at the time of when a control response becomes oscillatory.

- "Starting ST plus Vibration (PID Constant Only)" has been set for "Self-tuning setting" in "Application Setting".

■When the temperature process value (PV) is out of the temperature measuring range

The self-tuning is not executed. CH1 Self-tuning disable status (Un\G411, b8) is turned on.

■When a value other than 0 (0.0%/s) has been set for "Output Change Amount Limiter" of "Limiter setting" in "Application Setting"

The self-tuning is not executed. CH1 Self-tuning disable status (Un\G411, b8) is turned on.

■When 'CH1 AUTO/MAN mode shift' (Un\G518) has been set to MAN (1)

The self-tuning is not executed. CH1 Self-tuning disable status (Un\G411, b8) is turned on.

■When the setting variation rate limiter has been set to a value other than 0 (0°C (°F))

When a value other than 0 (0°C (°F)) has been set for each of the following settings, CH1 Self-tuning disable status (Un\G411, b8) is turned on.

- "Setting change rate limiter" of "Limiter setting" in "Application Setting"
- "Setting change rate limiter (Temperature drop)" of "Limiter setting" in "Application Setting"

■When the heating-cooling control or position-proportional control has been selected as the control mode

The self-tuning is not executed.

Discontinuation of self-tuning

The following operation during the self-tuning discontinues the self-tuning.

- When "Self-tuning setting" in "Application Setting" has been changed to "Do Not Run the ST"

The self-tuning operation in process is discontinued and the self-tuning is not executed after that. (An error does not occur.)

Whether the self-tuning is being executed or not can be checked in 'CH1 Auto tuning status' (X4).

Conditions in which the self-tuning ends in failure

Under the following conditions, the self-tuning ends in failure. When the self-tuning ends in failure, CH1 Self-tuning error (Un\G411, b10) is turned on.

- After the self-tuning was started, 6000 seconds (1 hour and 40 minutes) or longer have passed.
- The variation speed of the temperature process value (PV) during the self-tuning is slower than 1.125 (°C/min).
- 'CH1 Temperature process value (PV)' (Un\G402) has been out of the temperature measuring range.
- Required measurement data was not obtained because the manipulated value (MV) did not reach the upper limit output limiter value or the lower limit output limiter value before the completion of the measurement.
- The temperature process value (PV) that was supposed to increase after the self-tuning was started with the starting ST, and decreased by 1°C (°F) or more instead.
- The temperature process value (PV) that was supposed to decrease after the self-tuning was started with the starting ST, and increased by 1°C (°F) or more instead.
- The setting for the buffer memory areas in the following table was changed during self-tuning.

Buffer memory		Reference
CH1 Set value (SV) setting ^{*1}	Un\G430	Page 238 CH1 Set value (SV) setting
CH1 Proportional band (P) setting	Un\G431	Page 238 CH1 Proportional band (P) setting
CH1 Integral time (I) setting	Un\G432	Page 240 CH1 Integral time (I) setting
CH1 Derivative time (D) setting	Un\G433	Page 241 CH1 Derivative time (D) setting
CH1 Unused channel setting	Un\G502	Page 251 CH1 Unused channel setting
CH1 Control output cycle setting	Un\G504	Page 253 CH1 Control output cycle setting
CH1 Upper limit output limiter	Un\G508	Page 256 CH1 Upper limit output limiter
CH1 Lower limit output limiter	Un\G509	Page 257 CH1 Lower limit output limiter
CH1 Output variation amount limiter	Un\G510	Page 258 CH1 Output variation amount limiter
CH1 Setting variation rate limiter/setting variation rate limiter (temperature rise)	Un\G513	Page 260 CH1 Setting variation rate limiter/setting variation rate limiter (temperature rise)
CH1 Setting variation rate limiter (temperature drop)	Un\G514	Page 261 CH1 Setting variation rate limiter (temperature drop)
CH1 Direct/reverse action setting	Un\G515	Page 261 CH1 Direct/reverse action setting
CH1 AUTO/MAN mode shift	Un\G518	Page 263 CH1 AUTO/MAN mode shift
CH1 Primary delay digital filter setting	Un\G563	Page 293 CH1 Primary delay digital filter setting
CH1 Sensor correction value setting	Un\G565	Page 295 CH1 Sensor correction value setting

*1 Only during start-up

Precautions

- Before starting the temperature control using the temperature control module, power on a controlled object such as a heater. When the temperature control is started while the heater power supply is off, the PID constants for the response different from original characteristics are calculated by the self-tuning.

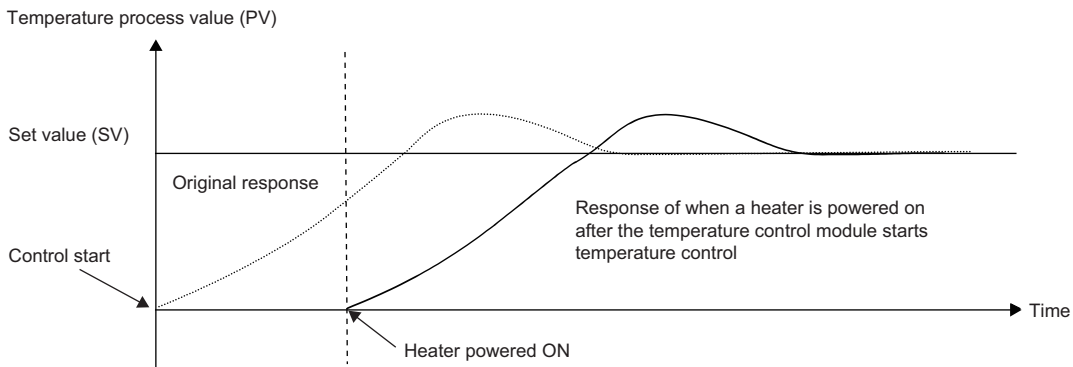

- Do not use the self-tuning function for controlled objects where a great disturbance (uncontrollable disturbance) occurs periodically. Doing so may cause improper PID constants to be calculated by the self-tuning. When the self-tuning function is used for such objects, improper PID constants are set and the response for the set value (SV) change or disturbance becomes slow. Use the disturbance suppression function for the controlled objects where a disturbance occurs periodically. ( Page 113 Disturbance Suppression Function)

1.13 Direct/reverse Action Selection Function

Whether to execute a PID operation with a direct action or a reverse action can be selected.

This function can be used in all the control methods (two-position control, P control, PI control, PD control, and PID control).

(☞ Page 16 Control Method)

For details on the operation, refer to the following.

(☞ Page 318 Actions of the temperature control module)

Setting method

Configure the setting as follows.

☞ [Navigation window] ⇒ [Parameter] ⇒ Target module ⇒ [Module Parameter] ⇒ [Application Setting] ⇒ [Normal Operation/Reverse Operation Setting]

1.14 RFB Limiter Function

The RFB (reset feedback) function operates when deviation (E) continues for a long period of time.

When the deviation (E) continues for a long period of time, this function prevents the PID operation results (manipulated value (MV)) calculated by integral actions from exceeding the effective range of the manipulated value (MV).

This function automatically operates when the PID control is executed. No setting is required.

Point

When a PID operation result is larger than the upper limit output limiter value, the temperature control module operates as follows.

- The RFB function levels the manipulated value (MV) to the upper limit output limiter value by feeding back an excess value to the integral value.

When a PID operation result is smaller than the lower limit output limiter value, the temperature control module operates as follows.

- The RFB function levels the manipulated value (MV) to the lower limit output limiter value by feeding back a required value to the integral value.

1.15 Derivative Action Selection Function

This function improves dynamic characteristics by selecting a suitable derivative action for fixed value actions or ramp actions.

Action

Each type of derivative action operates as shown below.

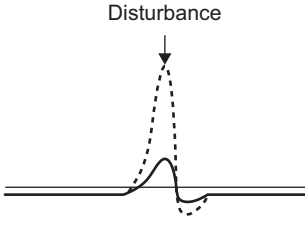
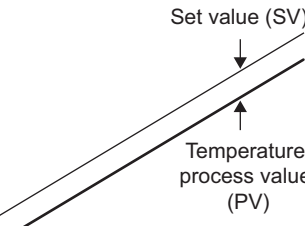
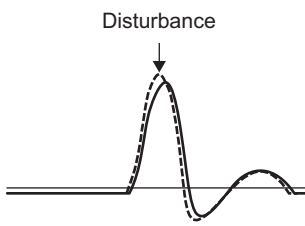
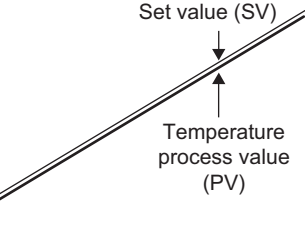
Setting of "Derivative action selection"	Action		
Measured Value Derivative (0)	<p>Fixed value action</p> 	<p>Ramp action</p> 	<p>This setting effectively prevents the temperature from being affected by a disturbance. However, the performance to follow the set value can be low.</p>
Deviation Derivative (1)	<p>Fixed value action</p> 	<p>Ramp action</p> 	<p>This setting allows the temperature to follow the set value well. However, the temperature get affected by a disturbance greatly.</p>

Setting method

Configure the setting as follows.

 [Navigation window] ⇒ [Parameter] ⇒ Target module ⇒ [Module Parameter] ⇒ [Application Setting] ⇒ [Derivative action selection]

1.16 Simple Two-degree-of-freedom

In addition to the PID control, this function selects a suitable response speed for the set value (SV) change from three levels to simply achieve the two-degree-of-freedom PID control.

General PID controls are called one-degree-of freedom PID control. In the one-degree-of freedom PID control, when PID constants to improve "response to the change of the set value (SV)" have been set, "response to the disturbance" degrades. Conversely, when PID constants to improve "response to the disturbance" have been set, "response to the change of the set value (SV)" degrades.

Compared to one-degree-of freedom PID control, "response to the change of the set value (SV)" and "response to the disturbance" can be compatible with each other in the two-degree-of-freedom PID control.

Note that required parameter settings increase and PID constants can hardly be automatically set by the auto tuning function for complete two-degree-of-freedom PID control. Therefore, the temperature control module operates in the simple two-degree-of-freedom PID control for which parameters are simplified.

In the PID control (simple two-degree-of-freedom) of the temperature control module, a form that allows users to use PID constants making good "response to the change of the set value (SV)" and "response to the disturbance" can be selected from the following three types.

- Fast
- Normal
- Slow

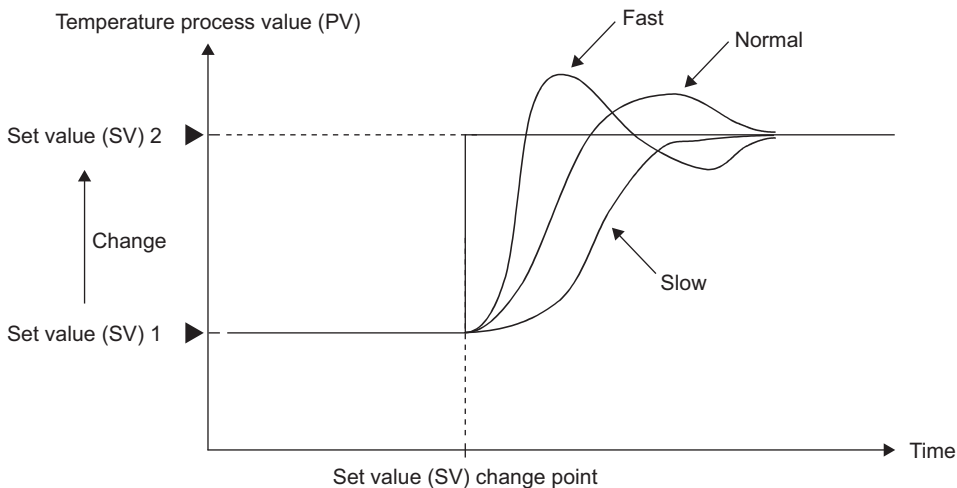

Setting method

Configure the setting as follows.

 [Navigation window] ⇒ [Parameter] ⇒ Target module ⇒ [Module Parameter] ⇒ [Application Setting] ⇒ [Control basic parameters] ⇒ [Control Response Parameters]

1.17 Auto-setting at Input Range Change

When the input range is changed, the related buffer memory data is automatically changed to prevent the values in those buffer memory areas from being out of the setting range. The following figure shows the setting timing.

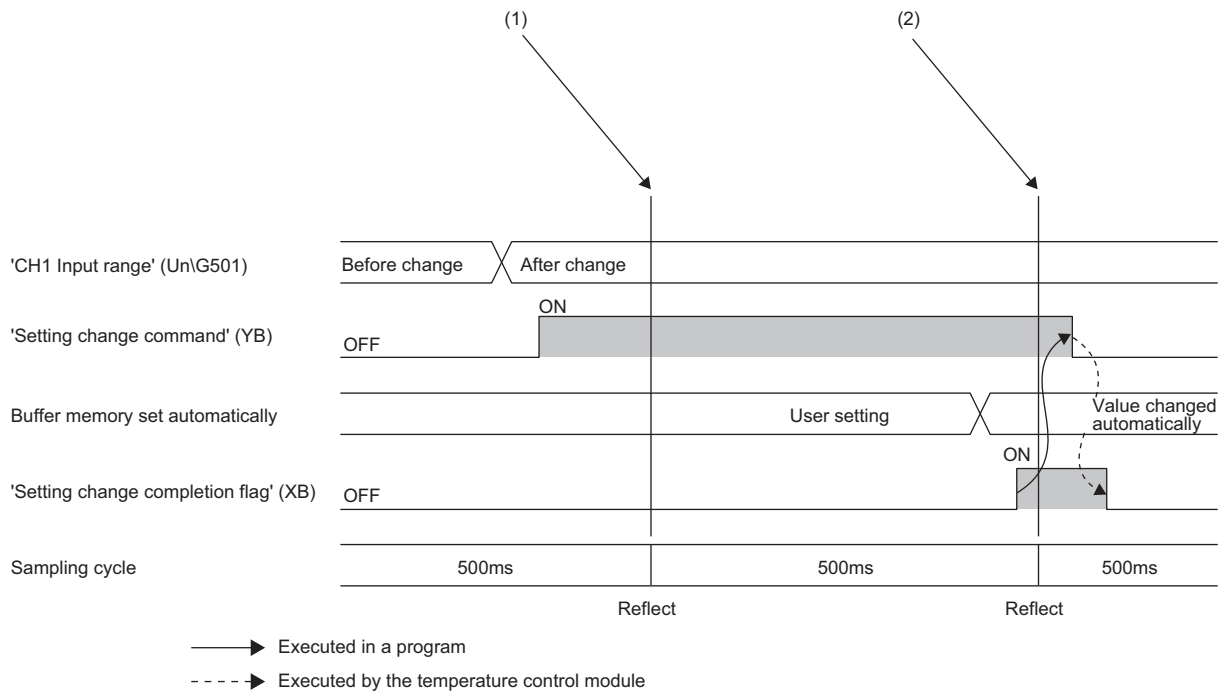

(1) Output signals and values in buffer memory areas are read when the processing by 250ms or 500ms^{*1} is started.

(2) Change the values in buffer memory areas that are automatically set after the processing every 250ms or 500ms^{*1}, and turn on and off 'Setting change command' (YB).

*1 The cycle to be used depends on the setting of "Sampling cycle selection" in "Base Setting".

Buffer memory areas to be automatically set

Refer to the following.

☞ Page 250 When the input range automatic change setting has been set to Enable (1) ('Automatic setting at input range change' (in the Q compatible mode) (UnG1024, b0) in the Q compatible mode)

Setting method

Configure the setting as follows.

☞ [Navigation window] ⇒ [Parameter] ⇒ Target module ⇒ [Module Parameter] ⇒ [Base Setting] ⇒ [Automatic setting at input range change]

1.18 Setting Variation Rate Limiter Setting Function

In the setting variation rate limiter setting, set the variation rate of the set value (SV) per a set unit time for when the set value (SV) is changed. Setting variation rate limiters for the temperature rise and the temperature drop can be set in a batch or individually.

Setting method

■Temperature rise/fall batch/individual setting

Configure the setting as follows.

[Navigation window] ⇒ [Parameter] ⇒ Target module ⇒ [Module Parameter] ⇒ [Base Setting] ⇒ [Setting change rate limiter setting]

■Variation amount setting

- When setting limiters in a batch

Set only "Setting change rate limiter".

[Navigation window] ⇒ [Parameter] ⇒ Target module ⇒ [Module Parameter] ⇒ [Application Setting] ⇒ [Limiter setting]

- When setting limiters individually

Set "Setting change rate limiter" and "Setting change rate limiter (Temperature drop)".

[Navigation window] ⇒ [Parameter] ⇒ Target module ⇒ [Module Parameter] ⇒ [Application Setting] ⇒ [Limiter setting]

■Setting a unit time

Set a unit time in "Setting change rate limiter unit time setting".

[Navigation window] ⇒ [Parameter] ⇒ Target module ⇒ [Module Parameter] ⇒ [Application Setting] ⇒ [Limiter setting]

Ex.

When "Temperature Rise/Temperature Drop Individual Setting" has been set for "Setting change rate limiter setting" in "Base Setting"

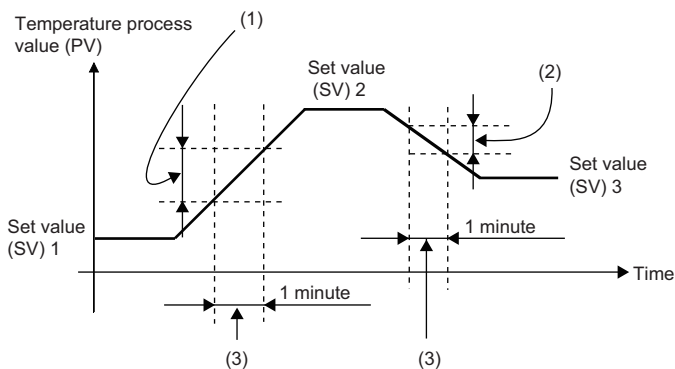

- (1) "Setting change rate limiter" of "Limiter setting" in "Application Setting"
- (2) "Setting change rate limiter (Temperature drop)" of "Limiter setting" in "Application Setting"
- (3) "Setting change rate limiter unit time setting" of "Limiter setting" in "Application Setting"

1.19 Sensor Correction Function

When there is an error between the temperature process value (PV) and actual temperature due to measurement conditions, this function corrects the error. The following two types are available.

- Normal sensor correction (one-point correction) function
- Sensor two-point correction function

Point

- In the Q compatible mode, set a value within the range of -5000 to 5000 (-50.00% to 50.00%) to the full scale of the set input range.
- When the sensor correction is executed with the engineering tool, the memory having the capacity of 700MB or larger is required. Check the memory in use has the capacity of 700MB or larger and execute the sensor correction.

Normal sensor correction (one-point correction) function

This function uses the value set in "Sensor Correction Value Setting" in "Application Setting" as the error correction value for correcting the error.

Ex.

When a value within the range of -200.0°C to 200.0°C has been set for "Input range setting" of "Control basic parameters" in "Application Setting", the actual temperature is 60°C, and the temperature process value (PV) is 58°C. Set "2°C" for "Sensor Correction Value Setting" in "Application Setting".

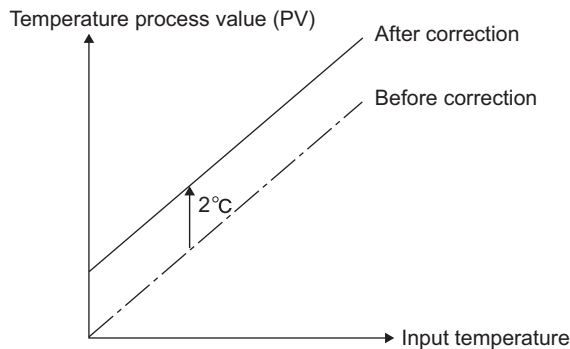

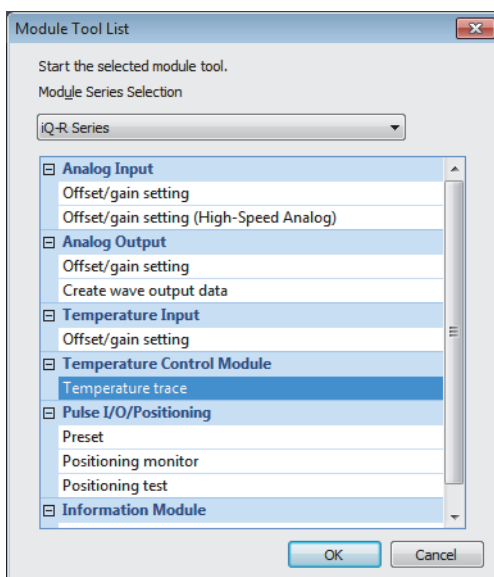

■ Procedure for executing the sensor correction (one-point correction) (when using the engineering tool)

[Tool] ⇒ [Module Tool List]

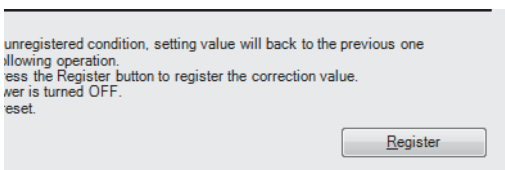
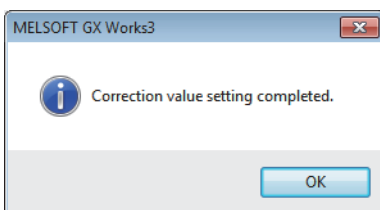
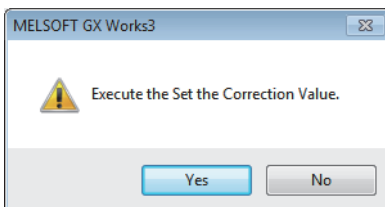
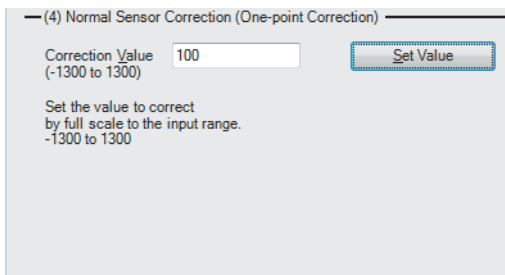
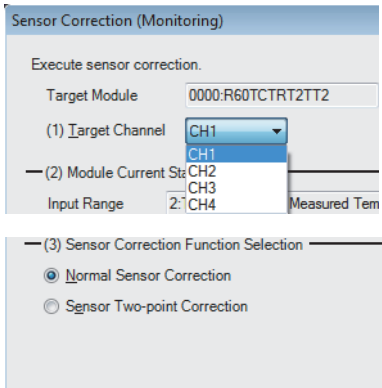
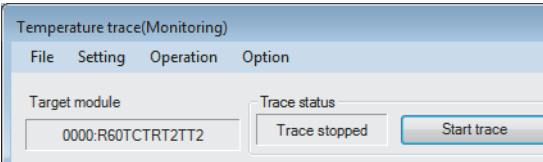
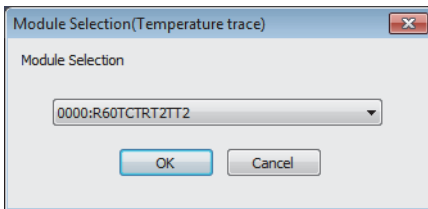

1. Select "Temperature trace" of "Temperature Control Module" and click the [OK] button.



2. Select the module to which the sensor correction is executed and click the [OK] button.
3. Select "Sensor Correction" from the following.
 [Option] ⇒ [Sensor correction]
4. Select a channel to which the sensor correction is executed for "Target Channel".
5. Select "Normal Sensor Correction" for "Sensor Correction Function Selection".
6. Input a value for "Sensor Correction" and click the [Set Value] button.
7. Click the [Yes] button.
8. Click the [OK] button.
9. To back up the correction value in the non-volatile memory, click the [Register] button.

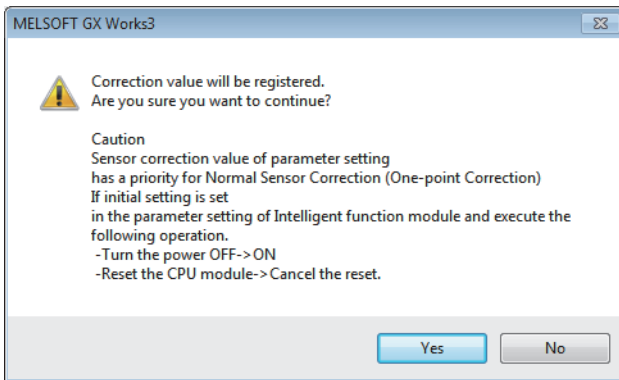

10. Click the [Yes] button.

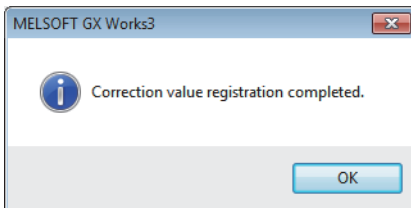

11. Click the [OK] button.

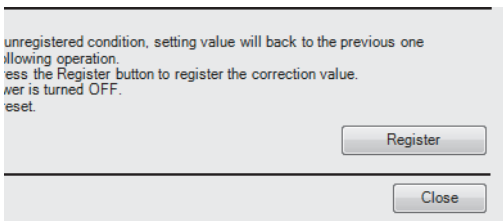

12. Click the [Close] button.

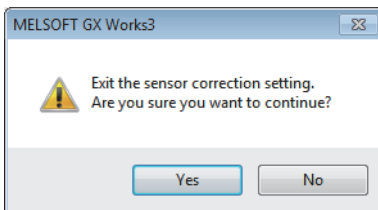

13. Click the [Yes] button.

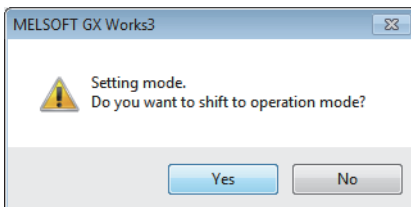

14. Click the [Yes] button.

Point



When the initial setting has been configured for "Sensor Correction Value Setting" in "Application Setting", the value set for "Sensor Correction Value Setting" in "Application Setting" is used instead of the correction value determined in Step 9 by executing the following operations.

- Turning off and on the power
- Resetting and clearing the reset of the CPU module

To use the correction value determined in Step 9 after the above operations are executed, correct the value set for "Sensor Correction Value Setting" in "Application Setting" and write the value to the programmable controller. Before correcting the value set for "Sensor Correction Value Setting", check the temporal operation to be executed after the correction with the setting determined in Step 9.

■ Procedure for executing the sensor correction (one-point correction) (when using a program)

Configure the setting by the following procedure.

1. Set 'Sensor correction function selection' (Un\G564) to Normal sensor correction (one-point correction) (0). ( Page 294 CH1 Sensor correction function selection)
2. Set a value for 'CH1 Sensor correction value setting' (Un\G565). ( Page 295 CH1 Sensor correction value setting)

Sensor two-point correction function

With this function, an error between the temperature process value (PV) and the actual temperature between the two points selected in advance (a correction offset value and a correction gain value) is stored. Based on this gradient, the error between the temperature detected by a sensor and the actual temperature is corrected.

Configure the sensor two-point correction setting in the setting mode ('Setting/operation mode status' (X1): Off). Set "Monitor" for "Stop mode setting" of "Control basic parameters" in "Application Setting".

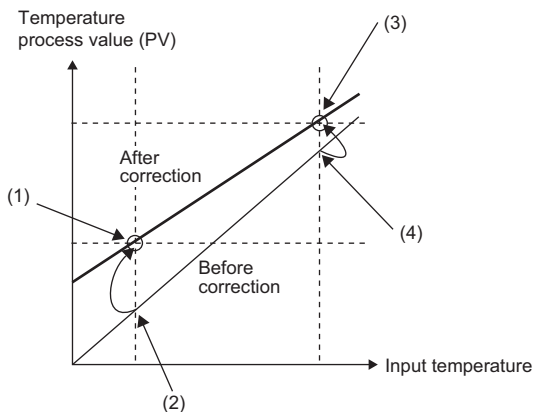

- (1) 'CH1 Sensor two-point correction offset value (corrected value)' (Un\G569)
- (2) 'CH1 Sensor two-point correction offset value (measured value)' (Un\G568)
- (3) 'CH1 Sensor two-point correction gain value (corrected value)' (Un\G571)
- (4) 'CH1 Sensor two-point correction gain value (measured value)' (Un\G570)

■ Procedure for executing the sensor correction (two-point correction) (when using the engineering tool)

 [Tool] ⇒ [Module Tool List]

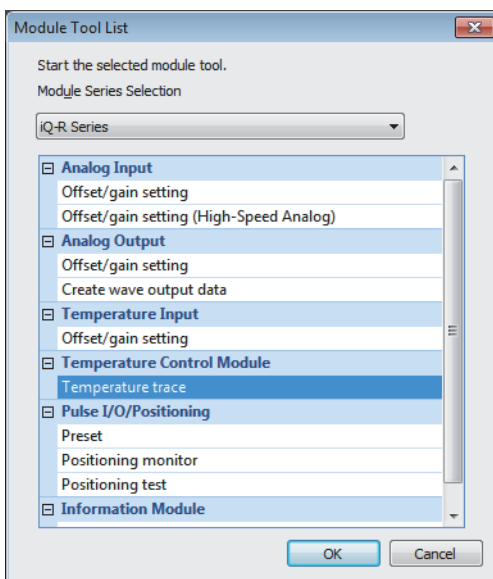

1. Select "Temperature trace" of "Temperature Control Module" and click the [OK] button.

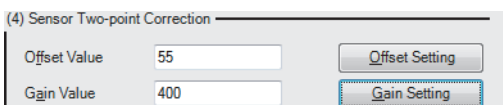
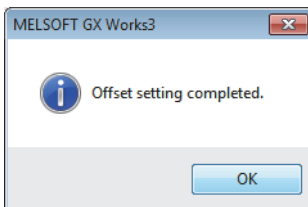
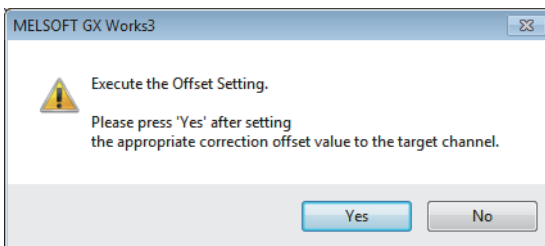
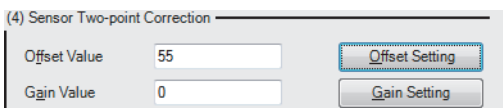
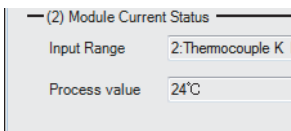
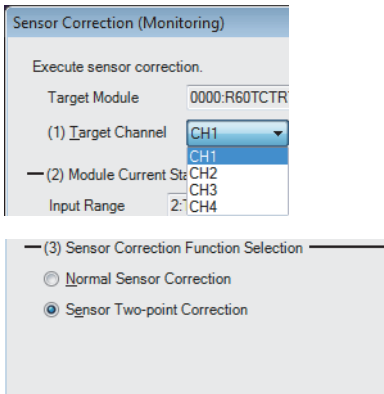
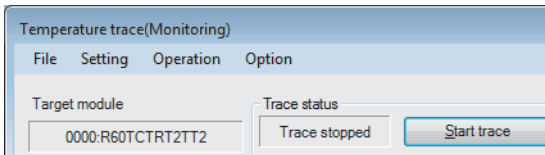
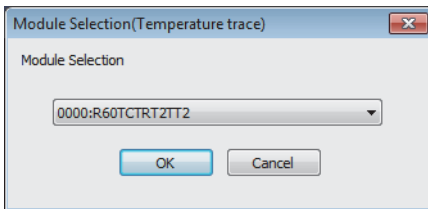

2. Select the module to which the sensor correction is executed and click the [OK] button.
3. Select "Sensor Correction" from the following.
 [Option] ⇒ [Sensor correction]
4. Select a channel to which the sensor correction is executed for "Target Channel".
5. Select "Sensor Two-point Correction" for "Sensor Correction Function Selection".
6. Monitor "Process value" and input the correction offset value.* 1
7. Set the temperature process value (PV) corresponding to the input for "Offset Value". After setting the value, click the [Offset Setting] button.
8. Click the [Yes] button.
9. Click the [OK] button.
10. Monitor "Process value" and input the correction gain value. After setting the value, click the [Gain Setting] button.

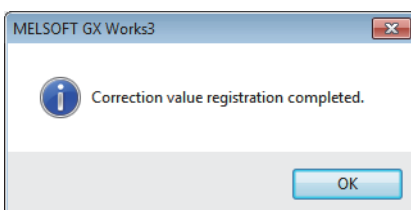
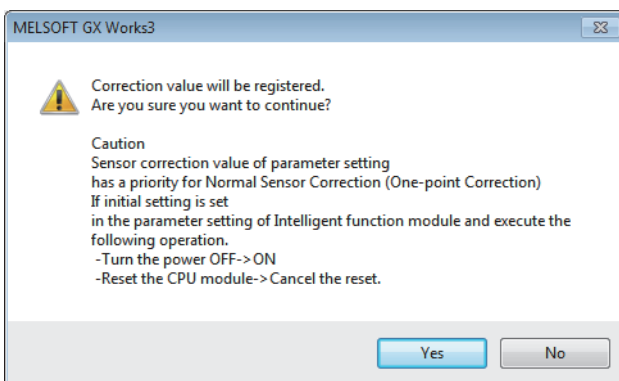
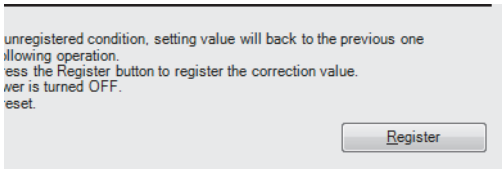
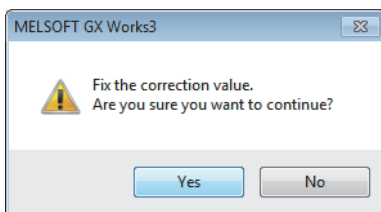
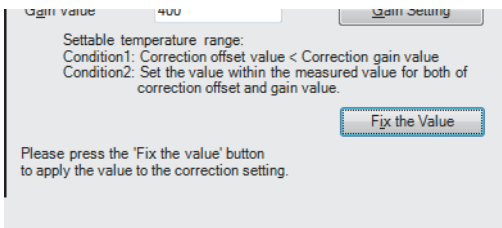
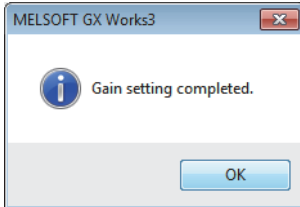
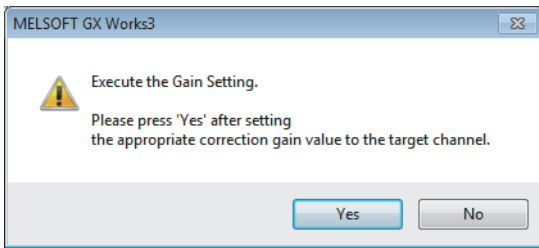

11. Click the [Yes] button.

12. Click the [OK] button.

13. Click the [Fix the Value] button.

14. Click the [Yes] button.

15. To back up the correction value in the non-volatile memory, click the [Register] button.

16. Click the [Yes] button.

17. Click the [OK] button.

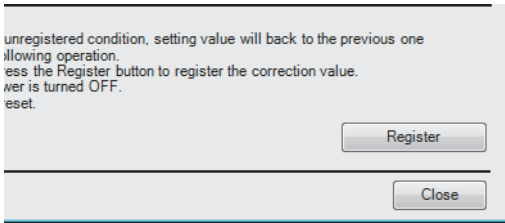

18. Click the [Close] button.

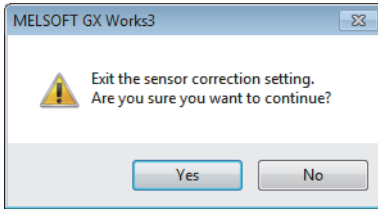

19. Click the [Yes] button.

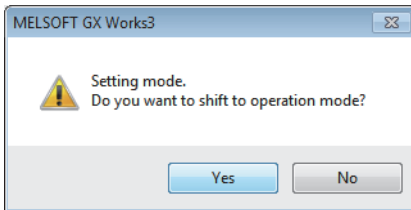

20. Click the [Yes] button.

*1 Enter the value using devices such as a thermocouple, platinum resistance thermometer, and standard DC voltage generator, or based on a general resistance value.

■ Procedure for executing the sensor correction (two-point correction) (when using a program)

Configure the setting by the following procedure.

1. Shift the mode to the setting mode. (Turn on and off 'Setting/operation mode command' (Y1).) (☞ Page 158 Setting/operation mode command)
2. Set 'CH1 Stop mode setting' (Un\G503) to Monitor (1). (☞ Page 252 CH1 Stop mode setting)
3. Set 'CH1 Sensor correction function selection' (Un\G564) to Sensor two-point correction (1). (☞ Page 294 CH1 Sensor correction function selection)

4. Input the correction offset value.

Enter the value using devices such as a thermocouple, platinum resistance thermometer, and standard DC voltage generator, or based on a general resistance value.

5. Set the temperature process value (PV) corresponding to the input for 'CH1 Sensor two-point correction offset value (corrected value)' (Un\G569). (☞ Page 297 CH1 Sensor two-point correction offset value (corrected value))
6. Set 'CH1 Sensor two-point correction offset latch request' (Un\G566) to Latch request (1). (☞ Page 295 CH1 Sensor two-point correction offset latch request)
7. Check that 'CH1 Sensor two-point correction offset latch completion' (Un\G419) becomes Latch completed (1). (☞ Page 237 CH1 Sensor two-point correction offset latch completion)

When the latch is completed, the temperature process value (PV) is stored in 'CH1 Sensor two-point correction offset value (measured value)' (Un\G568). (☞ Page 296 CH1 Sensor two-point correction offset value (measured value))

8. Set 'CH1 Sensor two-point correction offset latch request' (Un\G566) to No request (0). (☞ Page 295 CH1 Sensor two-point correction offset latch request)

9. Input the correction gain value.

Enter the value using devices such as a thermocouple, platinum resistance thermometer, and standard DC voltage generator, or based on a general resistance value.

10. Set the temperature process value (PV) corresponding to the input for 'CH1 Sensor two-point correction gain value (corrected value)' (Un\G571). (☞ Page 298 CH1 Sensor two-point correction gain value (corrected value))
11. Set 'CH1 Sensor two-point correction gain latch request' (Un\G567) to Latch request (1). (☞ Page 296 CH1 Sensor two-point correction gain latch request)
12. Check that 'CH1 Sensor two-point correction gain latch completion' (Un\G420) becomes Latch completed (1). (☞ Page 237 CH1 Sensor two-point correction gain latch completion)

When the latch is completed, the temperature process value (PV) is stored in 'CH1 Sensor two-point correction gain value (measured value)' (Un\G570). (☞ Page 297 CH1 Sensor two-point correction gain value (measured value))

13. Set 'CH1 Sensor two-point correction gain latch request' (Un\G567) to No request (0). (☞ Page 296 CH1 Sensor two-point correction gain latch request)

14. Turn off and on 'Setting change command' (YB). (☞ Page 160 Setting change command)

15. Check that 'Setting change completion flag' (XB) is on. (☞ Page 156 Setting change completion flag)

16. Turn on and off 'Setting change command' (YB). (☞ Page 160 Setting change command)

17. Shift the mode to the operation mode. (Turn off and on 'Setting/operation mode command' (Y1).) (☞ Page 158 Setting/operation mode command)

18. Check that the ERR LED is off.

When the ERR LED cannot be turned off, retry the setting from Step 4 or 9.

Point

- When a CH□ Sensor two-point correction setting error (error code: 1A△□H) occurs during the sensor two-point correction, correctly configure the setting for the sensor two-point correction. (The value set for the sensor two-point correction when an error occurred is not written to the temperature control module.)
- To use the value set for the sensor two-point correction even after the power is turned off and on or the CPU module is reset and the reset is cleared, turn off and on 'Setting value backup command' (Y8).

1.20 Primary Delay Digital Filter

By setting the primary delay digital filter, a temperature process value (PV) with smoothed transient noise can be output.

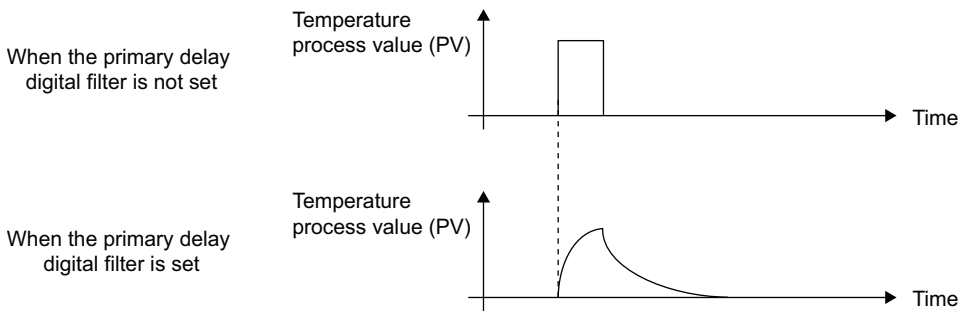

Set the time for the temperature process value (PV) to change by 63.3% in the primary delay digital filter.

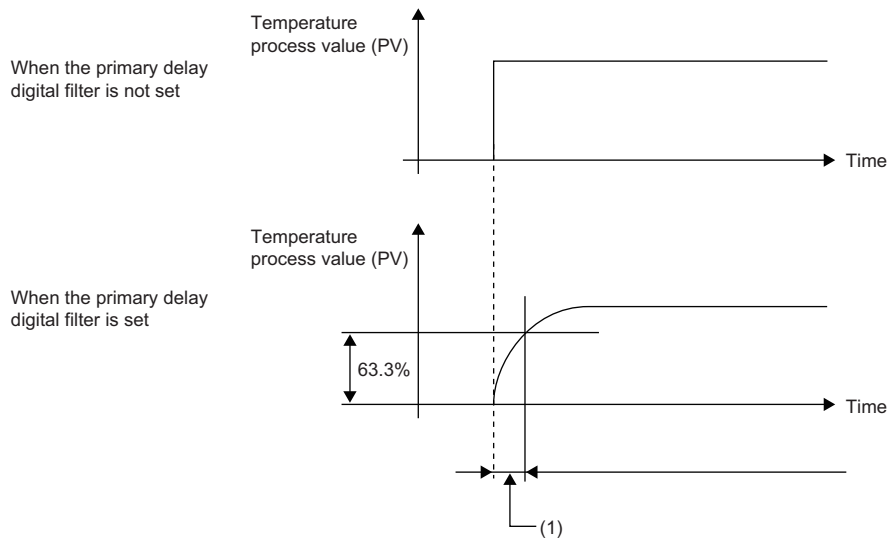

(1) "Primary Delay Digital Filter Setting" in "Application Setting"

Setting method

Configure the setting as follows.

[Navigation window] ⇒ [Parameter] ⇒ Target module ⇒ [Module Parameter] ⇒ [Application Setting] ⇒ [Primary Delay Digital Filter Setting]

Ex.

The following shows the temperature of when 3 (3s) has been set for "Primary Delay Digital Filter Setting" in "Application Setting" and the temperature process value (PV) is changed from 250.0°C to 260.0°C.

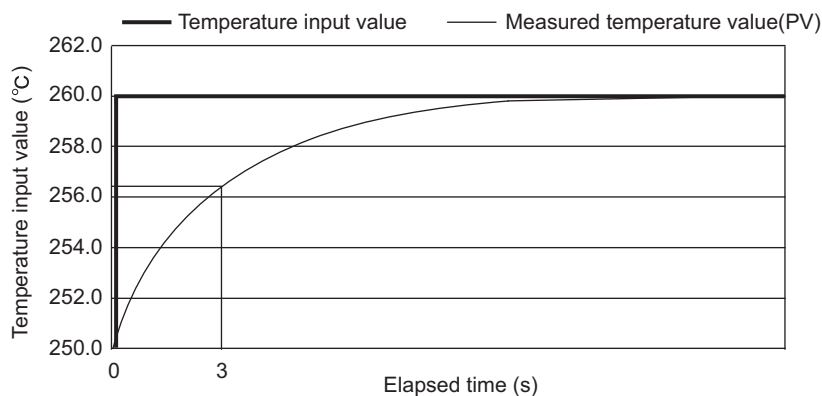

The temperature reaches 256.3°C that is 63.3% of the temperature process value (PV) in three seconds after the temperature input value has reached 250.0°C.

1.21 Moving Average Processing

Moving average processing can be set to a temperature process value (PV). With this function, the fluctuation of the temperature process value (PV) can be reduced in an electrically noisy environment or in the environment where the temperature process value (PV) fluctuates greatly.

To hasten the response of the temperature process value (PV), disable the moving average processing.

Setting method

Configure the settings.

1. Set "Enable" for the following setting.

 [Navigation window] ⇒ [Parameter] ⇒ Target module ⇒ [Module Parameter] ⇒ [Base Setting] ⇒ [Moving averaging process setting]

2. Set the number of times to execute the moving average processing by the following procedure.

 [Navigation window] ⇒ [Parameter] ⇒ Target module ⇒ [Module Parameter] ⇒ [Application Setting] ⇒ [Number of moving averaging]

Point

- When "Disable" has been set for "Moving averaging process setting" in "Base Setting", the value set for "Number of moving averaging" in "Application Setting" is ignored.
- For the module, the moving average processing is enabled and the number of times to execute the moving average processing has been set to 2 times as default. Change the settings if necessary.

1.22 Scaling Function

This function can convert temperature process values (PV) into the set width to import them in the buffer memory. For example, the range of -100°C to 100°C can be scaled into the range of 0 to 4000.

Scaling target

Usually, 'CH1 Temperature process value (PV)' (Un\G402) is the scaling target. However, values of other analog modules (such as an A/D converter module) on the system can be set as the scaling targets by setting a 200s value for "Input range setting" of "Control basic parameters" in "Application Setting". For details, refer to the following.

 Page 68 Setting method

Point

This section uses 'CH1 Temperature process value (PV)' (Un\G402) as the scaling target for explanation. To scale a value input from other analog modules (such as an A/D converter module), replace 'CH1 Temperature process value (PV)' (Un\G402) with 'CH1 Temperature process value (PV) for input with another analog module' (Un\G438) in the explanation and set values.

Monitoring the scaling value

The temperature process value (PV) after the scaling processing is stored in the following buffer memory area.

- 'CH1 Process value (PV) scaling value' (Un\G412)

A scaling value is calculated as follows.

$$\text{'CH1 Process value (PV) scaling value' (Un\G412)} = \frac{(\text{SH} - \text{SL}) \times (\text{PX} - \text{PMin})}{\text{PMax} - \text{PMin}} + \text{SL}$$

- PX: 'CH1 Temperature process value (PV)' (Un\G402)
- PMax: The maximum value of "Input range setting" of "Control basic parameters" in "Application Setting"
- PMin: The minimum value of "Input range setting" of "Control basic parameters" in "Application Setting"
- SH: "Process value (PV) scaling upper limit value" of "Scaling setting" in "Application Setting"
- SL: "Process value (PV) scaling lower limit value" of "Scaling setting" in "Application Setting"

■ Calculation example

Ex.

A calculation example of the scaling of the temperature process value (PV) into percentage

- "Input range setting" of "Control basic parameters" in "Application Setting": 38 (Temperature measuring range: -200.0°C to 400.0°C)
- "Process value (PV) scaling upper limit value" of "Scaling setting" in "Application Setting": 100
- "Process value (PV) scaling lower limit value" of "Scaling setting" in "Application Setting": 0

$$\begin{aligned} \text{'CH1 Process value (PV) scaling value' (Un\G412)} &= \frac{(100 - 0) \times (3600 - (-2000))}{4000 - (-2000)} + 0 \\ &= 93.333... \\ &= 93 \text{ (All decimal places are rounded off to an integer.)} \end{aligned}$$

■ Setting method

1. Set "Enable" or "Disable" for "Process value (PV) scaling function enable/disable setting".

 [Navigation window] ⇒ [Parameter] ⇒ Target module ⇒ [Module Parameter] ⇒ [Application Setting] ⇒ [Scaling setting] ⇒ [Process value (PV) scaling function enable/disable setting]

2. Set "Process value (PV) scaling upper limit value".

 [Navigation window] ⇒ [Parameter] ⇒ Target module ⇒ [Module Parameter] ⇒ [Application Setting] ⇒ [Scaling setting] ⇒ [Process value (PV) scaling upper limit value]

3. Set "Process value (PV) scaling lower limit value".

 [Navigation window] ⇒ [Parameter] ⇒ Target module ⇒ [Module Parameter] ⇒ [Application Setting] ⇒ [Scaling setting] ⇒ [Process value (PV) scaling lower limit value]

Point

- Even though the lower limit value has been set to be equal to or larger than the upper limit value in the above settings, an error does not occur. Scaling is executed according to the formula. ( Page 65 Monitoring the scaling value)
- When a value out of the temperature measuring range has been measured, the value set as the upper limit value or lower limit value is stored in 'CH1 Process value (PV) scaling value' (Un\G412).

1.23 ON Delay Output Function

This function enables users to configure settings considering the delay time (response/scan time delay) of an actual transistor output.

By monitoring ON delay output flag and external outputs, the settings can be used for the program that judges the disconnection of external outputs. The following figure shows an application example of ON delay output flag.

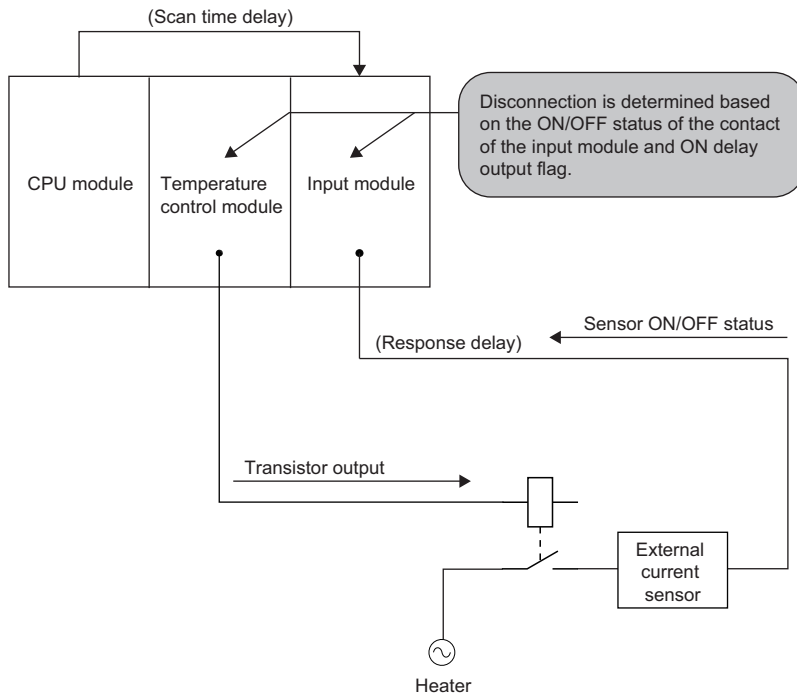

Setting method

Configure the setting as follows.

- [Navigation window] ⇒ [Parameter] ⇒ Target module ⇒ [Module Parameter] ⇒ [Application Setting] ⇒ [Transistor output monitor ON delay time setting]

1.24 Input/output (with Another Analog Module) Function

This function can input and output with other analog modules (including A/D converter module and D/A converter module) on the system.

Input

The temperature control module generally uses the temperature measured by the thermocouple or platinum resistance thermometer connected to the module as the temperature process value (PV). The temperature control module can use the digital input value of the current or voltage converted in another analog module (such as A/D converter module) on the system as a temperature process value (PV).

■Setting method

1. Select one of "Input with Another Analog Module Measured Temperature Range (0 to 4000)" to "Input with Another Analog Module Measured Temperature Range (0 to 32000)" in the following setting.
 [Navigation window] ⇒ [Parameter] ⇒ Target module ⇒ [Module Parameter] ⇒ [Application Setting] ⇒ [Control basic parameters] ⇒ [Input range setting]
2. Store the value of another analog module (such as an A/D converter module) in 'CH1 Temperature process value (PV) for input with another analog module' (Un\G438).

Point

- When the setting procedure 2 is executed without the setting procedure 1, an out of setting range error (error code: 1950H) occurs.
- When this function is used, the value in 'CH1 Temperature process value (PV) for input with another analog module' (Un\G438) is the target of the temperature process value (PV) scaling function. ( Page 65 Scaling Function)

Output

Instead of the transistor output from the temperature control module, an analog output value from another analog module (such as a D/A converter module) can be used as the manipulated value (MV).

■Setting method

1. Set the resolution of the manipulated value (MV) by the following procedure.
 [Navigation window] ⇒ [Parameter] ⇒ Target module ⇒ [Module Parameter] ⇒ [Application Setting] ⇒ [Resolution of the manipulated value for output with another analog module]
2. Store the value in 'CH1 Manipulated value (MV) for output with another analog module' (Un\G407) in the buffer memory of another analog module (such as a D/A converter module).

Point

- When the manipulated value (MV) is -5.0% to 0.0%, 0 is stored in Manipulated value (MV) for output with another analog module. When the manipulated value (MV) is 100.0% to 105.0%, 4000, 12000, 16000, 20000, or 32000 is stored in Manipulated value (MV) for output with another analog module.
- The manipulated value (MV) (%) is stored into Manipulated value (MV) for output with another analog module (digital output value) in real time.

1.25 Alert Function

This function issues an alert when a temperature process value (PV) or deviation (E) meets the condition set in advance. Use this function to activate danger signals of devices or safety devices. Alerts of the alert function are classified into input alerts and deviation alerts depending on the setting of the alert mode.

- Input alert: Upper limit input alert, lower limit input alert
- Deviation alert: Upper limit deviation alert, lower limit deviation alert, upper/lower limit deviation alert, within-range alert

Input alert

When the temperature process value (PV) is equal to or greater than the alert set value, the system issues the upper limit input alert.

When the temperature process value (PV) is equal to or smaller than the alert set value, the system issues the lower limit input alert.

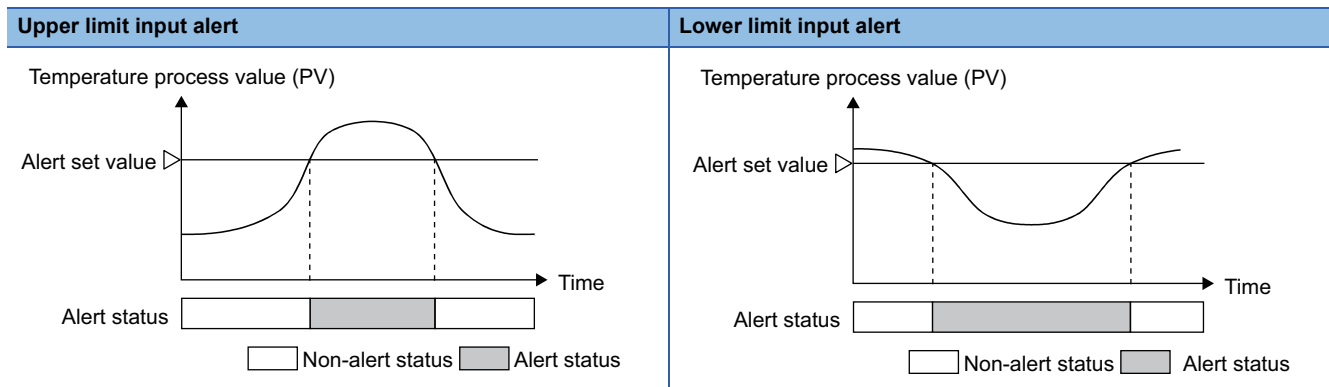

Setting method

Set an alert mode. (☞ Page 76 Alert mode)

- Upper limit input alert: Set "Upper Limit Input Alert" as the alert mode.
- Lower limit input alert: Set "Lower Limit Input Alert" as the alert mode.

Deviation alert

When the deviation (E) between the temperature process value (PV) and the set value (SV) meets a particular condition, the system issues the deviation alert.

The set value (SV) to be referred to is either "Set value (SV) monitor" or "Set value (SV) setting" depending on the set alert mode. When a setting variation rate limiter has been set, "Set value (SV) monitor" follows the set value (SV) at the specified variation rate.

The following table shows the application of each set value (SV) of when a setting variation rate limiter has been set. When the deviation alert is used, refer to the following.

Reference target of the set value (SV)	Application (when the set value (SV) has changed)
'CH1 Set value (SV) monitor' (Un\G406)	This value is used when the temperature process value (PV) needs to follow the changing set value (SV) within a certain deviation (E). When the temperature process value (PV) does not follow the set value (SV) and goes out of the set deviation (E), an alert occurs.
"Target Value(SV) Setting" of "Control basic parameters" in "Application Setting"	This value is used when the temperature process value (PV) does not need to follow the changing set value (SV) and only the deviation (E) to the set value (SV) is used for the judgment of an alert. Even while the value in 'CH1 Set value (SV) monitor' (Un\G406) is changing, an alert is judged based on the deviation (E) to the set value (SV).

■ Setting the set value (SV) and the setting variation rate limiter

The following figures show the relation of two set values (SV) depending on whether a setting variation rate limiter has been set or not.

- When the setting variation rate limiter has not been set: The two set values (SV) are the same.

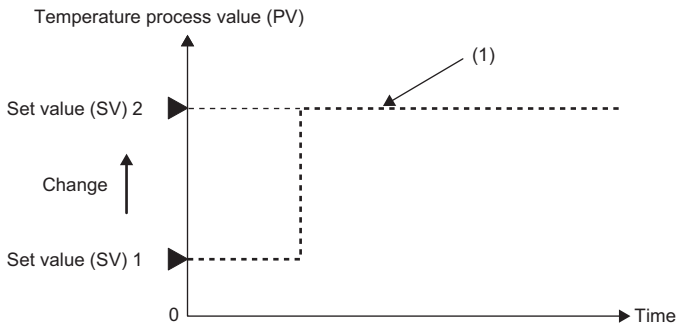

(1) "Target Value(SV) Setting" of "Control basic parameters" in "Application Setting" and 'CH1 Set value (SV) monitor' (Un\G406)

- When a setting variation rate limiter has been set: The value in 'CH1 Set value (SV) monitor' (Un\G406) follows the set value (SV) after the setting.

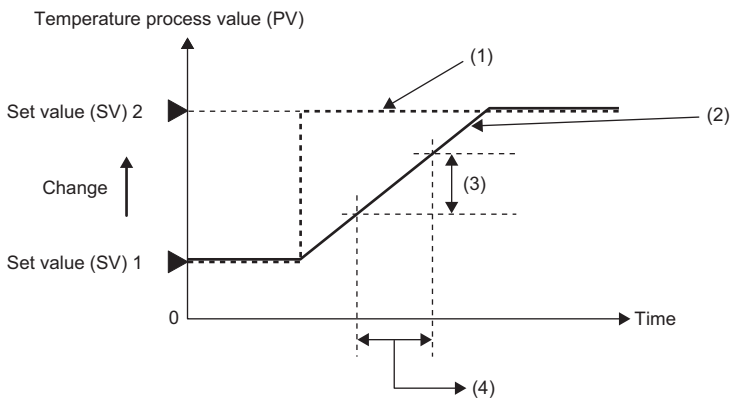

(1) "Target Value(SV) Setting" of "Control basic parameters" in "Application Setting"

(2) 'CH1 Set value (SV) monitor' (Un\G406)

(3) "Setting change rate limiter" of "Limiter setting" in "Application Setting"

(4) "Setting change rate limiter unit time setting" of "Limiter setting" in "Application Setting"

Upper limit deviation alert

When the deviation (E) is equal to or greater than the alert set value, the system issues a deviation alert.

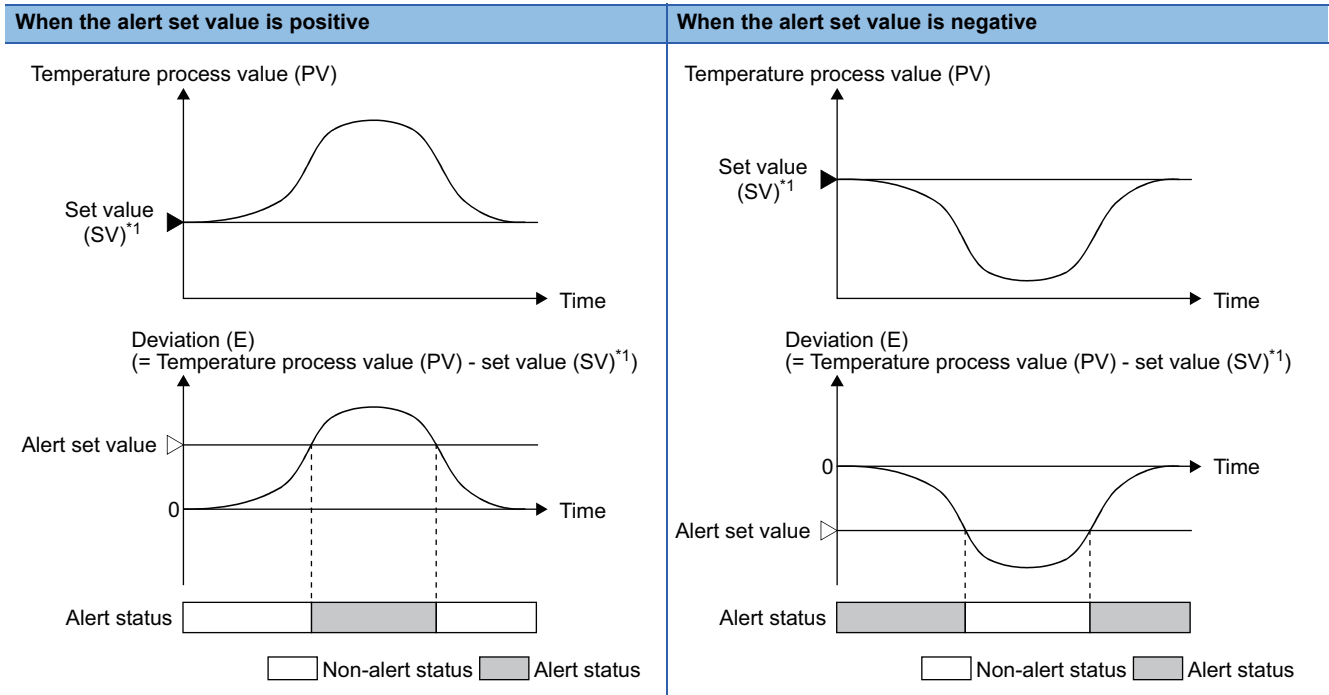

*1 Depending on the set alert mode, this value becomes the set value or the monitored value. The setting range of the alert set value is (- (Full scale of the input range)) to the full scale of the input range. (Page 70 Setting the set value (SV) and the setting variation rate limiter)

Lower limit deviation alert

When the deviation (E) is equal to or smaller than the alert set value, the system issues a deviation alert.

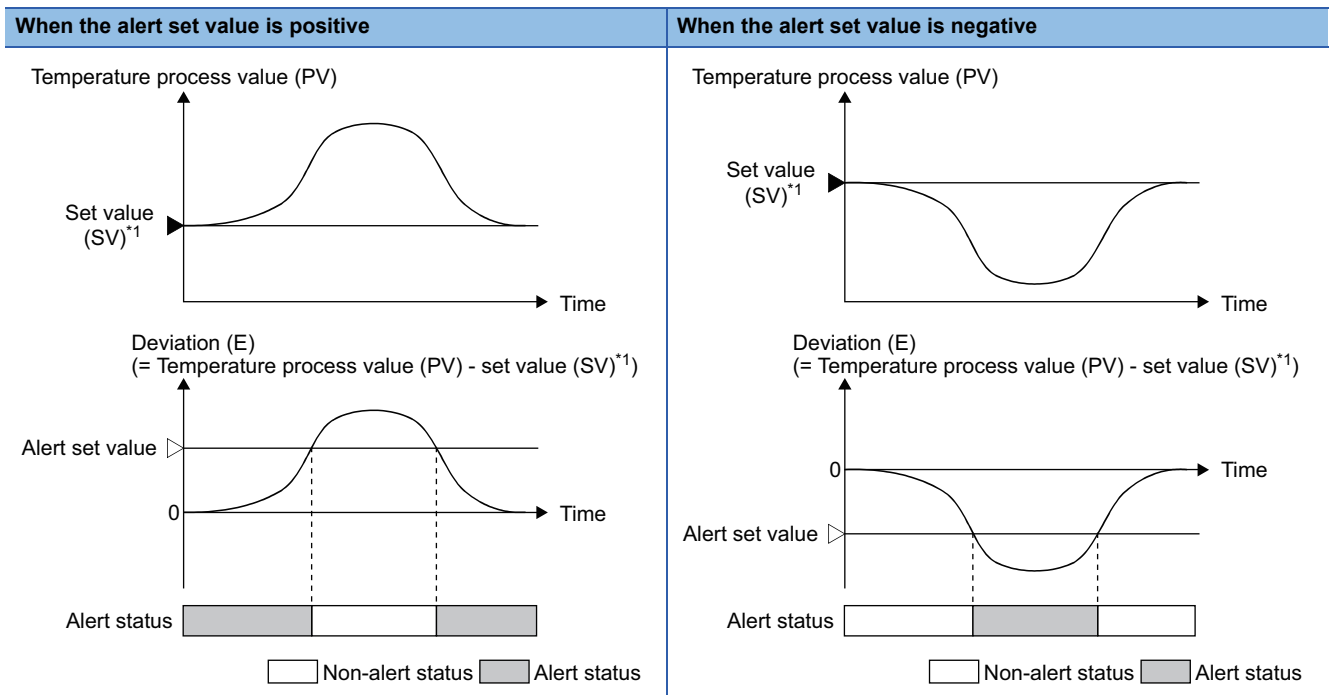

*1 Depending on the set alert mode, this value becomes the set value or the monitored value. The setting range of the alert set value is (- (Full scale of the input range)) to the full scale of the input range. (Page 70 Setting the set value (SV) and the setting variation rate limiter)

Upper/lower limit deviation alert

When one of the following conditions is satisfied, the system issues a deviation alert.

- Deviation (E) \geq Alert set value
- Deviation (E) \leq -(Alert set value)

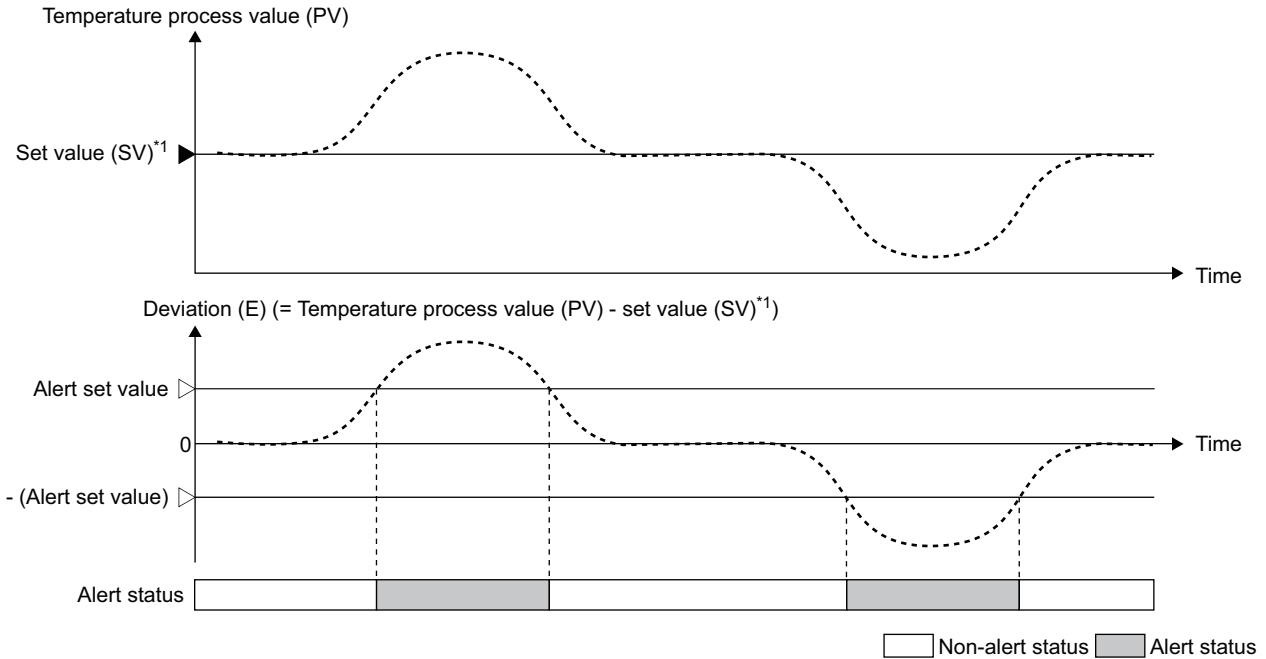

*1 Depending on the set alert mode, this value becomes the set value or the monitored value. The setting range of the alert set value is 0 to the full scale of the input range. (☞ Page 70 Setting the set value (SV) and the setting variation rate limiter)

Within-range alert

When the following condition is satisfied, the system issues an alert.

- -(Alert set value) \leq Deviation (E) \leq Alert set value

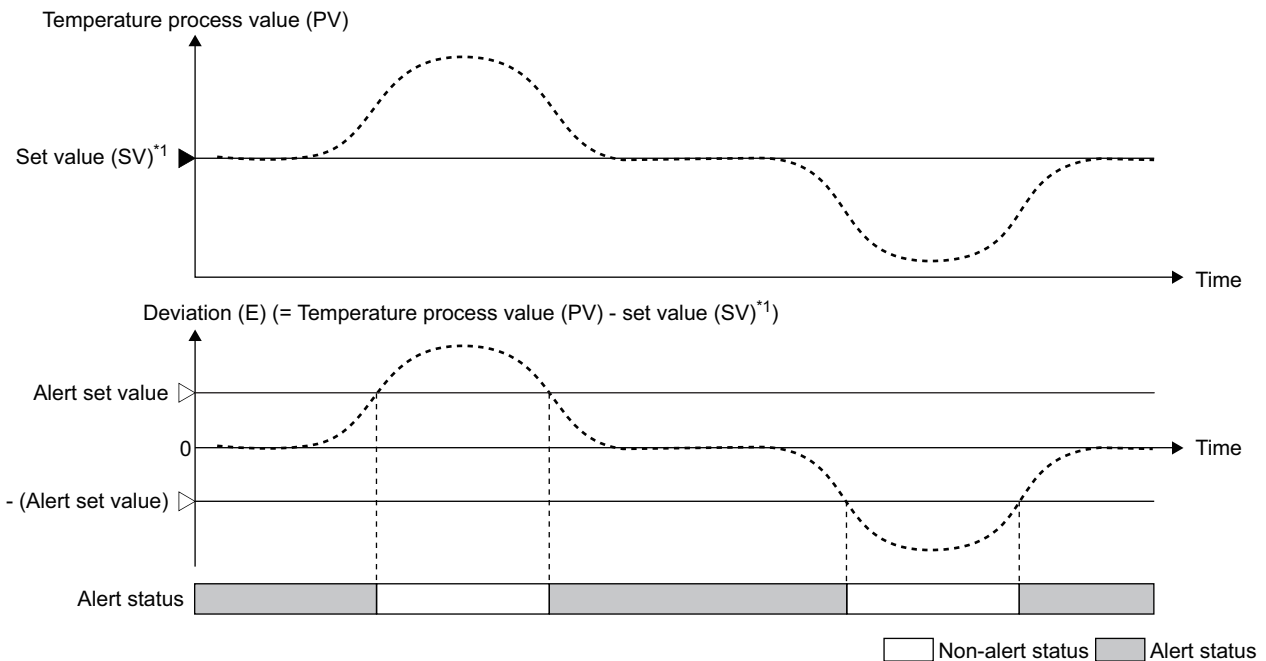

*1 Depending on the set alert mode, this value becomes the set value or the monitored value. The setting range of the alert set value is 0 to the full scale of the input range. (☞ Page 70 Setting the set value (SV) and the setting variation rate limiter)

■Setting method (Alert mode and the set value (SV) to be monitored)

From the reference targets of the set value (SV), set whether to use 'CH1 Set value (SV) monitor' (Un\G406) or "Target Value(SV) Setting" of "Control basic parameters" in "Application Setting" with the alert mode.

- When alerts need to be judged using the value in 'CH1 Set value (SV) monitor' (Un\G406), set one of the following values.

Alert mode setting	
Setting value	Alert mode name
3	Upper limit deviation alert
4	Lower limit deviation alert
5	Upper/lower limit deviation alert
6	Within-range alert
9	Upper limit deviation alert with wait
10	Lower limit deviation alert with wait
11	Upper/lower limit deviation alert with wait
12	Upper limit deviation alert with re-wait
13	Lower limit deviation alert with re-wait
14	Upper/lower limit deviation alert with re-wait

- When alerts need to be judged using the value of "Target Value(SV) Setting" of "Control basic parameters" in "Application Setting", set one of the following values.

Alert mode setting	
Setting value	Alert mode name
15	Upper limit deviation alert (use set value (SV) setting value)
16	Lower limit deviation alert (use set value (SV) setting value)
17	Upper/lower limit deviation alert (use set value (SV) setting value)
18	Within-range alert (use set value (SV) setting value)
19	Upper limit deviation alert with wait (use set value (SV) setting value)
20	Lower limit deviation alert with wait (use set value (SV) setting value)
21	Upper/lower limit deviation alert with wait (use set value (SV) setting value)
22	Upper limit deviation alert with re-wait (use set value (SV) setting value)
23	Lower limit deviation alert with re-wait (use set value (SV) setting value)
24	Upper/lower limit deviation alert with re-wait (use set value (SV) setting value)

Alert with wait

Even though the temperature process value (PV) or deviation (E) has been in an alert status when the mode is shifted from the setting mode to the operation mode ('Setting/operation mode command' (Y1) is turned off and on), this condition is ignored and no alert occurs. The alert function can be disabled until the temperature process value (PV) or deviation (E) goes out of the condition in which an alert occurs.

Ex.

When the alert mode has been set to "Lower Limit Deviation Alert with Wait"

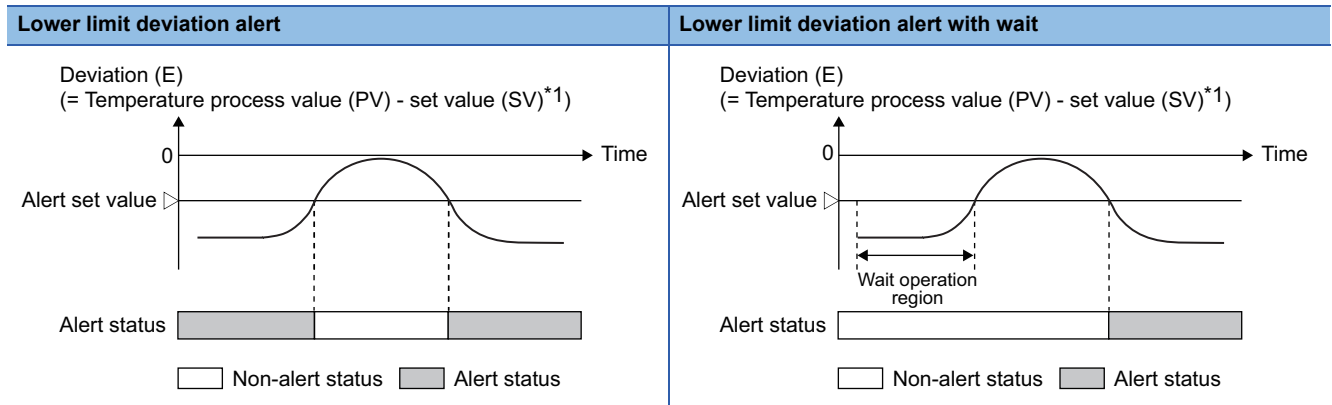

*1 Depending on the set alert mode, this value becomes the set value or the monitored value. (☞ Page 70 Setting the set value (SV) and the setting variation rate limiter)

Point

When the system goes into the non-alert status even once after an alert judgment has started following the set alert mode, an alert with wait is disabled even though the mode is shifted to the one with standby.

Setting method

Select one of the following alert modes. (☞ Page 76 Alert mode)

Alert mode setting	
Setting value	Alert mode name
7	Upper limit input alert with wait
8	Lower limit input alert with wait
9	Upper limit deviation alert with wait
10	Lower limit deviation alert with wait
11	Upper/lower limit deviation alert with wait
19	Upper limit deviation alert with wait (use set value (SV) setting value)
20	Lower limit deviation alert with wait (use set value (SV) setting value)
21	Upper/lower limit deviation alert with wait (use set value (SV) setting value)

Alert with re-wait

A function to deactivate the alert function once again when the set value (SV) is changed is added to an alert with wait. This is called an alert with re-wait.

When a control that changes the set value (SV) is executed, the alert that is supposed to occur can be avoided when the set value (SV) is changed by selecting an alert with re-wait.

Ex.

When the temperature process value (PV) is at the position shown as below before the set value (SV) change

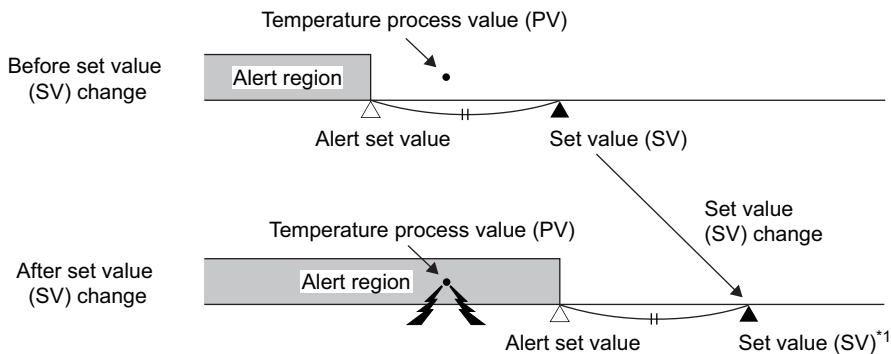

*1 Depending on the set alert mode, this value becomes the set value or the monitored value. (Page 70 Setting the set value (SV) and the setting variation rate limiter)

When the set value (SV) of a deviation alert is changed, the temperature process value (PV) goes into the alert area. Thus, the system goes into an alert status. To prevent the case above, alert outputs can be suspended.

Setting method

Select one of the following alert modes.

Alert mode setting	
Setting value	Alert mode name
12	Upper limit deviation alert with re-wait
13	Lower limit deviation alert with re-wait
14	Upper lower limit deviation alert re-wait
22	Upper limit deviation alert with re-wait (use set value (SV) setting value)
23	Lower limit deviation alert with re-wait (use set value (SV) setting value)
24	Upper/lower limit deviation alert with re-wait (use set value (SV) setting value)

When "Setting change rate limiter setting" in "Base Setting" has been set, an alert with re-wait cannot be enabled even though one of the following alert modes is selected.

Alert mode setting	
Setting value	Alert mode name
12	Upper limit deviation alert with re-wait
13	Lower limit deviation alert with re-wait
14	Upper/lower limit deviation alert with re-wait

The re-wait function is used to prevent the occurrence of an alert when the set value (SV) is changed.

When "Setting change rate limiter setting" in "Base Setting" has been set, the value in 'CH1 Set value (SV) monitor' (Un\G406) follows the set value (SV) and gradually changes when the set value (SV) is changed. When it is supposed that the re-wait function is enabled under such a situation, the re-wait function would be always active, and an alert would not be output even while the temperature process value (PV) is not following the value in 'CH1 Set value (SV) monitor' (Un\G406). To prevent such cases, the re-wait function is disabled when a setting variation rate limiter is used.

Condition for alert judgment

Whether the occurrence of an alert is judged or not depends on the following settings:

- 'Setting/operation mode command' (Y1) (☞ Page 158 Setting/operation mode command)
- "PID continuation Flag" of "Control basic parameters" in "Application Setting" (☞ Page 132 Application Setting)
- 'CH1 PID control forced stop command' (YC) (☞ Page 160 PID control forced stop command)
- "Stop mode setting" of "Control basic parameters" in "Application Setting" (☞ Page 132 Application Setting)

The following table shows the relation between each setting and the execution of alert judgment.

○: Executed, ×: Not executed

'Setting/operation mode command' (Y1)	"PID continuation Flag" of "Control basic parameters" in "Application Setting"	'CH1 PID control forced stop command' (YC)	"Stop mode setting" of "Control basic parameters" in "Application Setting"	Alert judgment	
Setting mode at power-on	Stop (0), Continue (1)	OFF, ON	Stop (0)	×	
			Monitor (1)	×	
			Alert (2)	○	
Operation mode (during operation)	Stop (0), Continue (1)	OFF	Stop (0), Monitor (1), Alert (2)	○	
		ON	Stop (0)	×	
			Monitor (1)	×	
Setting mode (after operation)	Stop (0)	OFF, ON	Stop (0)	×	
			Monitor (1)	×	
			Alert (2)	○	
	Continue (1)	OFF	Stop (0), Monitor (1), Alert (2)	○	
			ON	Stop (0)	×
				Monitor (1)	×
			Alert (2)	○	

When "Unused channel setting" in "Application Setting" has been set to "Unused", the alert judgment is not executed even though the above conditions are satisfied.

Point

For the timing of 'Setting/operation mode command' (Y1), refer to the following.

☞ Page 158 Setting/operation mode command

Condition in which 'CH1 Alert flag' (XC) turns off

The condition in which 'CH1 Alert flag' (XC) turns off differs depending on the following setting.

- "Stop mode setting" of "Control basic parameters" in "Application Setting" (☞ Page 132 Application Setting)

"Stop mode setting" of "Control basic parameters" in "Application Setting"	'CH1 Alert flag' (XC)
Stop (0)	When the cause of the alert is resolved or when the mode has shifted from the operation mode to the setting mode (when 'Setting/operation mode command' (Y1) is turned on and off)
Monitor (1)	
Alert (2)	When the cause of the alert is resolved

Setting alert modes and alert set values

The following describes the settings of alert modes and alert set values.

■Alert mode

Set alert modes.

Set "Alert 1 mode setting" to "Alert 4 mode setting" by the following procedure. Up to 4 items can be set.

Alert modes of Alert 1 to 4 correspond to the alert set values 1 to 4.

☞ [Navigation window] ⇒ [Parameter] ⇒ Target module ⇒ [Module Parameter] ⇒ [Application Setting] ⇒ [Alert setting]

■Alert set value

According to a selected alert mode, set the temperature at which CH1 Alert 1 (Un\G401, b8) to CH1 Alert 4 (Un\G401, b11) turn on. Up to 4 items can be set.

Set "Alert set value 1" to "Alert set value 4" by the following procedure.

Alert set values 1 to 4 correspond to the alert modes of Alert 1 to 4.

[Navigation window] ⇒ [Parameter] ⇒ Target module ⇒ [Module Parameter] ⇒ [Application Setting] ⇒ [Alert setting]

Setting an alert dead band

When the temperature process value (PV) or deviation (E) is close to the alert set value, the status may change repeatedly between the alert status and non-alert status due to inconsistent inputs.

In this case, by setting an alert dead band, repetition of the status change caused by inconsistent inputs can be prevented.

■Setting method

Configure the setting as follows.

[Navigation window] ⇒ [Parameter] ⇒ Target module ⇒ [Module Parameter] ⇒ [Application Setting] ⇒ [Alert setting] ⇒ [Alert dead band setting]

Ex.

When the alert mode has been set to "Upper Limit Input Alert"

When a value other than 0°C has been set for "Alert dead band setting" of "Alert setting" in "Application Setting", the system issues an alert when the input upper limit becomes equal to or greater than the alert set value. When the value becomes equal to or smaller than the alert dead band, the status changes to the non-alert status. (lower right figure)

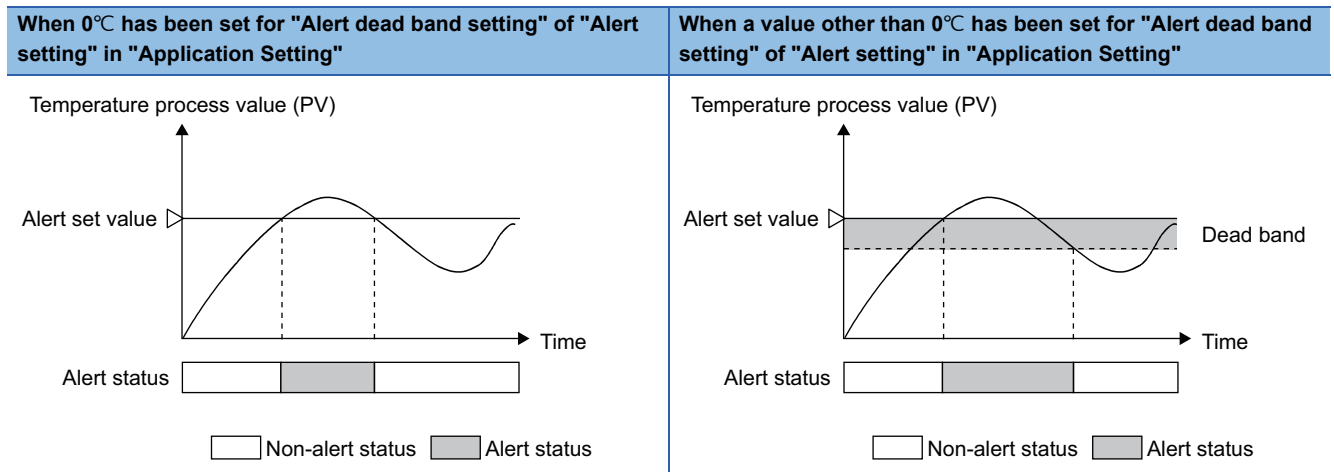

Setting of the number of alert delay

Set the number of times to execute sampling to judge an alert. By setting the number of times to execute sampling, when the temperature process value (PV) stays within the alert range after the temperature process value (PV) has reached the alert set value until the number of times to execute sampling exceeds the number of alert delay, an alert occurs.

■Setting method

Configure the setting as follows.

 [Navigation window] ⇒ [Parameter] ⇒ Target module ⇒ [Module Parameter] ⇒ [Application Setting] ⇒ [Alert setting] ⇒ [Number of alert delay]

Ex.

When the alert mode has been set to "Upper Limit Input Alert"

When 5 (times) is set as the number of alert delay, the system does not issue an alert when the number of times to execute sampling is 4 times or less.

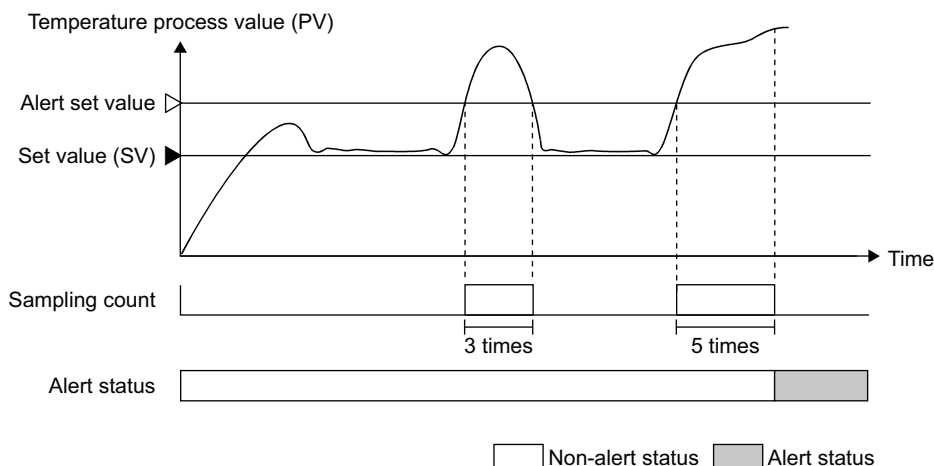

Alert mode and related settings

The following table shows the alert modes and the related settings described in this section.

Enabled or used: ○, Disabled or not used: —

Alert		Alert dead band setting	Number of alert delay	Alert with wait	Alert with re-wait
Input alert	Upper limit input alert	○	○	○	—
	Lower limit input alert	○	○	○	—
Deviation alert	Upper limit deviation alert	○	○	○	○
	Upper limit deviation alert (use set value (SV) setting value)	○	○	○	○
	Lower limit deviation alert	○	○	○	○
	Lower limit deviation alert (use set value (SV) setting value)	○	○	○	○
	Upper/lower limit deviation alert	○	○	○	○
	Upper/lower limit deviation alert (use set value (SV) setting value)	○	○	○	○
	Within-range alert	○	○	—	—
	Within-range alert (use set value (SV) setting value)	○	○	—	—

1.26 Rate Alarm Function

The temperature process value (PV) is monitored every rate alarm alert detection cycle. When the variation from the previously monitored value is greater than the rate alarm upper limit value or smaller than the rate alarm lower limit value, an alert occurs. The rate alarm is helpful to monitor the change of the temperature process value (PV) within a limited range. Rate alarm alert detection cycle = Value (times) set for "Rate alarm warning detection period" of "Rate alarm" in "Application Setting" × Sampling cycle (500ms/4 channels or 250ms/4 channels)

The temperature process value is judged every rate alarm alert detection cycle with the following formulas.

- (Present value of the temperature process value (PV) - Last value of the temperature process value (PV)) \geq Rate alarm upper limit value: A rate alarm upper limit alert occurs.
- (Present value of the temperature process value (PV) - Last value of the temperature process value (PV)) \leq Rate alarm lower limit value: A rate alarm lower limit alert occurs.

Checking the occurrence of an alert

While a rate alarm has occurred, 'CH1 Alert flag' (XC) turns on and the ALM LED turns on. In 'CH1 Alert definition' (Un\G401), whether an upper limit alert or a lower limit alert has occurred can be checked. ( Page 224 CH1 Alert definition)

Point

When an error that makes the ALM LED flash (such as a loop disconnection) has occurred, the ALM LED flashes.

Checking that the alert has been cleared

When the temperature process value (PV) has returned to within the setting range, CH1 Rate alarm upper limit (Un\G401, b4) or CH1 Rate alarm lower limit (Un\G401, b5) turns off. In addition, 'CH1 Alert flag' (XC) turns off and the ALM LED turns off.

Point

For 'CH1 Alert flag' (XC) and the ALM LED, the alert is not cleared when an alert other than rate alarms has occurred.

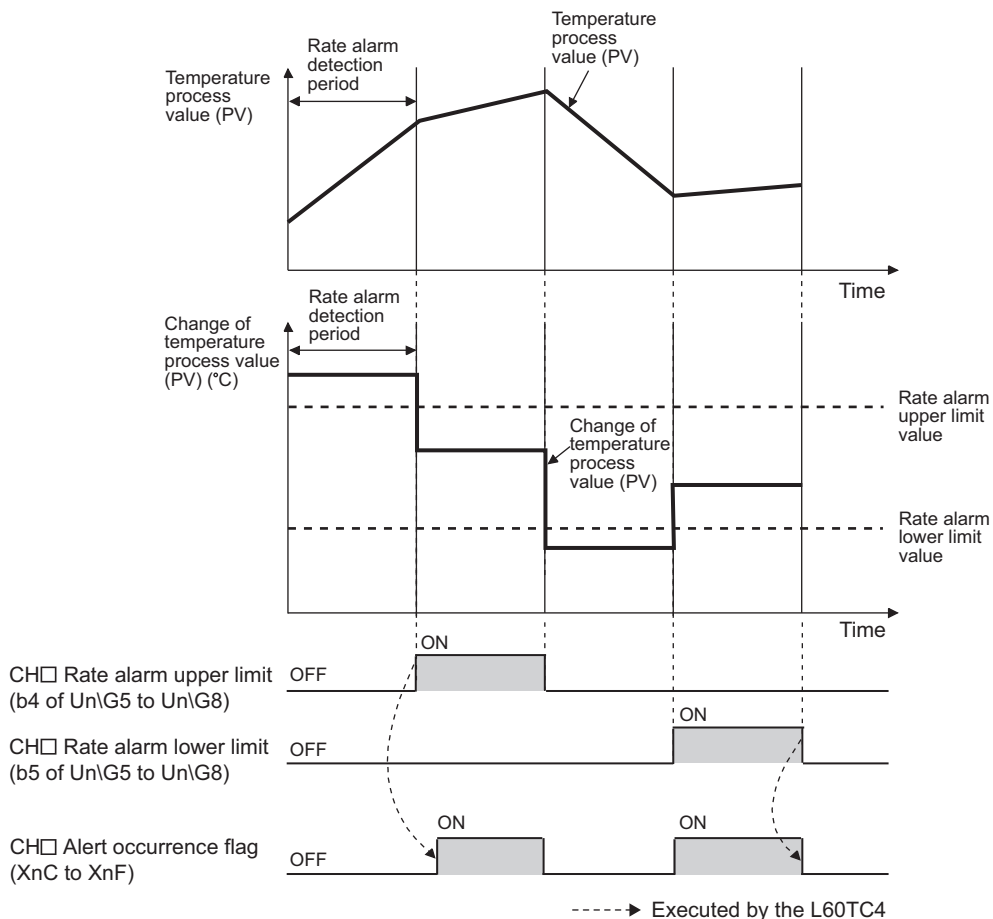

Setting method

Configure the setting as follows.

[Navigation window] ⇒ [Parameter] ⇒ Target module ⇒ [Module Parameter] ⇒ [Application Setting] ⇒ [Rate alarm]

■Precautions

When the resolution is 1, the temperature process value (PV) of the temperature control module is the actual temperature that was rounded off. The temperature process value (PV), the actual temperature that was rounded off, is also used for the judgment of the occurrence of a rate alarm.

Ex.

A setting example of the rate alarm upper limit value and the rate alarm lower limit value to monitor that the temperature process value (PV) is rising within a specified range

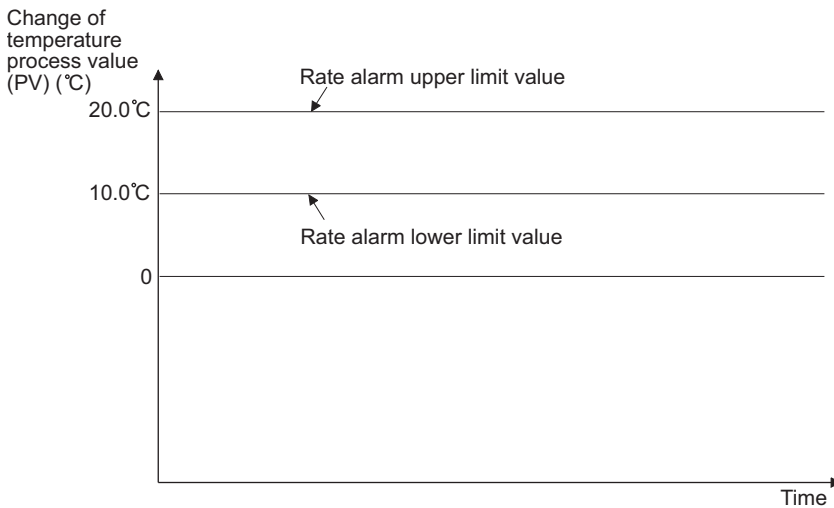

Ex.

A setting example of the rate alarm upper limit value and the rate alarm lower limit value to monitor that the temperature process value (PV) is falling within a specified range

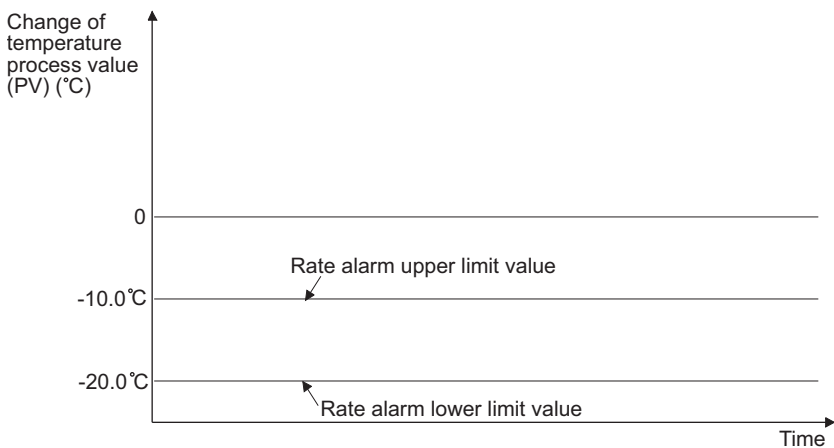

Ex.

A setting example of the rate alarm upper limit value and the rate alarm lower limit value to monitor that the temperature process value (PV) is changing within a specified range

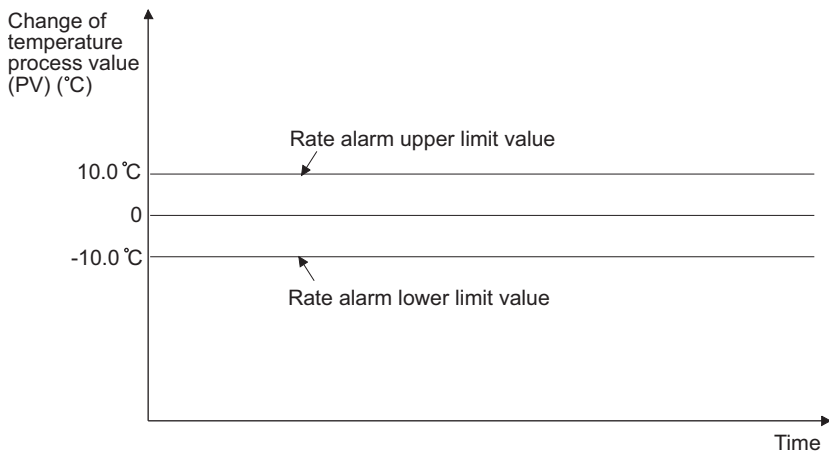

1.27 Heater Disconnection Detection Function

When a transistor output is on, this function checks whether a heater has been disconnected or not by using a heater current process value (load current value detected by a current sensor (CT)). This function compares the heater current process value and the heater disconnection alert current value. When the heater current process value becomes equal to or smaller than the heater disconnection alert current value, the heater is regarded as disconnected. However, when the transistor-output ON time is one of the following values, no heater disconnection is detected. (CH1 Heater disconnection detection (Un\G401, b12) remains off.)

- When the heater disconnection judgment mode is the normal mode: 500ms or shorter
- When the heater disconnection judgment mode is the high accuracy mode: 200ms or shorter

The following shows the timing when an alert is output.

- 500ms × n

n = Value set for "Heater disconnection/output off-time current error detection delay count" of "Loop disconnection detection setting" in "Application Setting"

When the heater disconnection status lasts longer than the time described above, the following operations are executed.

- The HBA LED turns on.
- 'CH1 Alert flag' (XC) turns on.
- CH1 Heater disconnection detection (Un\G401, b12) is turned on.
- CH□ Heater disconnection detection (alarm code: 088□) is stored in 'Latest alarm code' (Un\G3). (Page 141 When the temperature process value (PV) is abnormal)

Supported modules

- R60TCTRT2TT2BW
- R60TCRT4BW

Setting method

Configure the setting by the following procedure.

[Navigation window] ⇒ [Parameter] ⇒ Target module ⇒ [Module Parameter] ⇒ [CT setting]

1. Set the current sensor (CT) to be used for "CT selection".

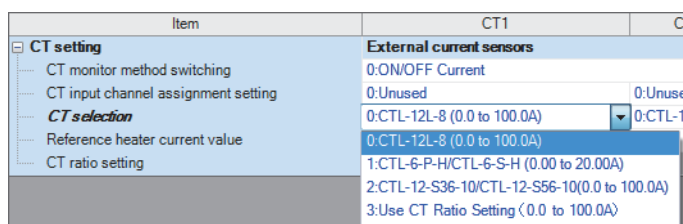

2. When using a current sensor (CT) other than the products manufactured by U.R.D.Co., LTD., set "CT ratio setting".

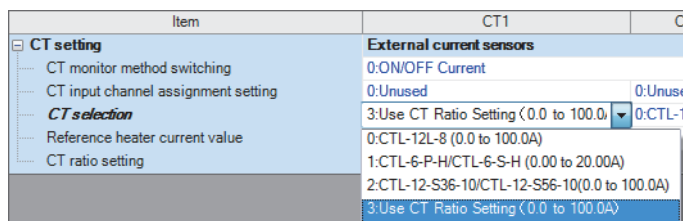

3. Set the channel to be assigned to CT□ in "CT input channel assignment setting".

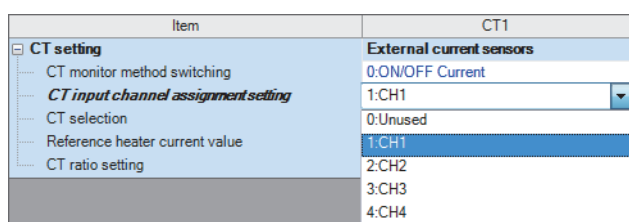

4. Monitor 'CT1 Heater current process value' (Un\G2030) and check the current value of when the heater is on.

Device Name	F	E	D	C	B	A	9	8	7	6	5	4	3	2	1	0	Current Value
U0/G2030	0	0	0	0	0	0	0	0	0	0	1	0	1	0	1	0	42
U0/G2031	0	0	0	0	0	0	0	0	0	0	0	0	0	0	0	0	0
U0/G2032	0	0	0	0	0	0	0	0	0	0	0	0	0	0	0	0	0
U0/G2033	0	0	0	0	0	0	0	0	0	0	0	0	0	0	0	0	0
U0/G2034	0	0	0	0	0	0	0	0	0	0	0	0	0	0	0	0	0

5. Set the value monitored with 'CT1 Heater current process value' (Un\G2030) in "Reference heater current value".

Item	CT1
CT setting	External current sensors
CT monitor method switching	0:ON/OFF Current
CT input channel assignment setting	1:CH1
CT selection	3:Use CT Ratio Setting (0.0 to 100.0A)
Reference heater current value	4.2 A
CT ratio setting	800

6. Set a judgment value to detect heater disconnections and output off-time current errors as a rate (%) of the reference heater current value in "Heater disconnection alert setting" of "Heater disconnection detection setting" in "Application Setting".

[Navigation window] ⇒ [Parameter] ⇒ Target module ⇒ [Module Parameter] ⇒ [Application Setting]

Item	CH1	CH2	
Heater disconnection detection setting	Set the heater disconnection detection.		
Heater disconnection alert setting	90 %	0 %	0 %

7. Set how many times heater disconnections are detected successively to regard the heater as disconnected for "Heater disconnection/output off-time current error detection delay count" of "Heater disconnection detection setting" in "Application Setting".

Heater disconnection/output off-time current error detection delay count	3 Times
Heater disconnection correction function selector	0:OFF

Point

- The standard setting value for "Heater disconnection alert setting" of "Heater disconnection detection setting" in "Application Setting" is 80%. However, the current value may significantly change depending on the characteristics of a heater or how the heater is used. Check that there is no problem in the actual system.

In the R mode

- An out of setting range error (error code: 1950H) occurs when "0:CTL-12L-8 (0.0 to 100.0A)", "2:CTL-12-S36-10/CTL-12-S56-10(0.0 to 100.0A)" or "3:Use CT Ratio Setting (0.0 to 100.0A)" has been set for "CT selection" of "CT setting" and the current value to be used as a judgment value to detect heater disconnections (Reference heater current value × CH□ Heater disconnection alert setting (%)) is smaller than 0.1A.
- In addition, an out of setting range error (error code: 1950H) occurs when "1:CTL-6-P-H/CTL-6-S-H (0.00 to 20.00A)" has been set for "CT selection" of "CT setting" and the current value to be used as a judgment value to detect heater disconnections (Reference heater current value × CH□ Heater disconnection alert setting (%)) is smaller than 0.01A.

In the Q compatible mode

- An out of setting range error (error code: 1950H) occurs when "0:CTL-12-S36-8 (0.0 to 100.0A)" or "2:Use CT Ratio Setting (0.0 to 100.0A)" has been set for "CT selection" of "CT setting" and the current value to be used as a judgment value to detect heater disconnections (Reference heater current value × CH□ Heater disconnection alert setting (%)) is smaller than 0.1A.
- In addition, an out of setting range error (error code: 1950H) occurs when "1:CTL-6-P/CTL-6-P-H (0.00 to 20.00A)" has been set for "CT selection" of "CT setting" and the current value to be used as a judgment value to detect heater disconnections (Reference heater current value × CH□ Heater disconnection alert setting (%)) is smaller than 0.01A.

Heater disconnection correction function

When a heater voltage drops, a heater current is reduced. The R60TCTRT2TT2BW and R60TCRT4BW detect heater disconnections by measuring a heater current. Thus, an accidental alert may be issued due to the voltage fluctuation caused when a heater voltage drops.

The heater disconnection correction function corrects the amount of the heater current reduced (heater disconnection correction), preventing the disconnections from being detected.

■ Calculation formula for heater disconnection correction

Calculate (CH□ Heater current value) - (Reference heater current value). The largest positive value is used as the correction value. When there is no positive value, the value with the smallest gap is the correction value. The heater current of each channel is corrected using a correction value. When the corrected value is larger than the heater disconnection alert setting value, a heater disconnection is detected.

Ex.

When "Heater disconnection alert setting" of "Heater disconnection detection setting" in "Application Setting" is 80% and the differences between CH□ Heater current value and the reference heater current value are the following values:

- CH1: -2%
- CH2: 5%
- CH3: -1%
- CH4: -17%

The following table shows the result.

Channel	Heater disconnection alert setting	Difference between CH□ Heater current value and the reference heater current value	Correction value	Difference between CH□ Heater current value and the reference heater current value after correction	Disconnection detection
CH1	80 (%)	-2%	5%	-7% (= -2% - 5%)	None
CH2		5%		0% (= 5% - 5%)	None
CH3		-1%		-6% (= -1% - 5%)	None
CH4		-17%		-22% (= -17% - 5%)	Detected

The correction value is 5%, and the heater disconnection detection judgment is executed on the following values: CH1: -7%, CH2: 0%, CH3: -6%, and CH4: -22%. Because the heater disconnection alert setting has been set to 80%, a disconnection is detected only in CH4.

Ex.

When "Heater disconnection alert setting" of "Heater disconnection detection setting" in "Application Setting" is 80% and the differences between CH□ Heater current value and the reference heater current value are the following values:

- CH1: -16%
- CH2: -17%
- CH3: -22%
- CH4: -19%

The following table shows the result.

Channel	Heater disconnection alert setting	Difference between CH□ Heater current value and the reference heater current value	Correction value	Difference between CH□ Heater current value and the reference heater current value after correction	Disconnection detection
CH1	80 (%)	-16%	-16%	0% (= -16% - (-16%))	None
CH2		-17%		-1% (= -17% - (-16%))	None
CH3		-22%		-6% (= -22% - (-16%))	None
CH4		-19%		-3% (= -19% - (-16%))	None

The correction value is -16%, and the heater disconnection detection judgment is executed on the following values: CH1: 0%, CH2: -1%, CH3: -6%, and CH4: -3%. Because the heater disconnection alert setting has been set to 80%, none of the channels are regarded as disconnected.

■Restrictions

- When only one channel has been used, the heater disconnection correction function does not work. To use this function, two or more channels have to be used.
- When multiple channels have been used with a heater that is on in one channel and heaters that are off in the other channels, the heater disconnection correction function does not work. Thus, disconnections may be detected even though there is no disconnection.
- The heater disconnection alert correction value can be 20% at maximum. When the heater disconnection alert setting value has been set to 80% as shown in the above two examples and if a voltage drops by 40% or more, the disconnection detection conditions are satisfied and a heater disconnection is detected even after the correction value of 20% has been applied.

■Setting method

Set the following item to "ON".

 [Navigation window] ⇒ [Parameter] ⇒ Target module ⇒ [Module Parameter] ⇒ [Application Setting] ⇒ [Heater disconnection detection setting] ⇒ [Heater disconnection correction function selection]

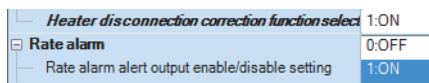

■Clearing the disconnection detection status

Detected disconnections are disabled by restoring the disconnection status and CH1 Heater disconnection detection (Un\G401, b12) turns on and off.

The timing of when a heater turns on differs depending on the settings of the following buffer memory areas.

- "Control output cycle setting" of "Control basic parameters" in "Application Setting"
- "Cooling control output cycle setting" of "Heating/cooling control setting" in "Application Setting"

1.28 Output Off-time Current Error Detection Function

Transistor output errors can be detected using this function. A current sensor (CT) for heater disconnection detection is used to check for errors of when transistor outputs are off.

A heater current process value and the heater disconnection alert current value are compared. If the heater current process value is larger than the heater disconnection alert current value, an output off-time current error occurs.

Detection of output off-time current errors is executed every 500ms. When the off time of a transistor output has been set as follows, output off-time current errors are not detected. (CH1 Output off-time current error (Un\G401, b14) remains off.)

- When the heater disconnection judgment mode is the normal mode: 500ms or shorter
- When the heater disconnection judgment mode is the high accuracy mode: 200ms or shorter

The following shows the timing when an alert is output.

- 500ms × n

n = Value set for "Heater disconnection/output off-time current error detection delay count" of "Loop disconnection detection setting" in "Application Setting"

When the output off-time current error status lasts longer than the time described above, the following operations are executed.

- The HBA LED turns on.
- 'CH1 Alert flag' (XC) turns on.
- CH1 Output off-time current error (Un\G401, b14) is turned on.
- CH□ Output off-time current error (alarm code: 08A□) is stored in 'Latest alarm code' (Un\G3).

Supported modules

- R60TCTRT2TT2BW
- R60TCRT4BW

Setting method

The setting method is the same as that for the heater disconnection detection function. (☞ Page 83 Heater Disconnection Detection Function)

1.29 Loop Disconnection Detection Function

This function detects errors that occurs in a control system (control loop) such as a load (heater) disconnection, an externally-operable device (such as a magnetic relay) failure, and input disconnections.

How an error is detected

From the point where the control output has reached the upper limit output limiter value or the lower limit output limiter value, the variation amount in the temperature process value (PV) is monitored every unit time set and heater and input disconnections are detected.

Examples of the errors detected

The following shows the examples of the errors detected.

■When control output is executed

The temperature control module detects an error because the temperature does not rise even while control output is being executed under the following conditions:

- When a heater is disconnected
- When input is disconnected or short-circuited
- When a contact point of an externally-operable device does not turn on

When the temperature does not rise by 2°C (°F) or higher within the set loop disconnection detection judgment time after the control output has reached the upper limit output limiter value, an alert is output. (The operation is reversed for a forward action.  Page 51 Direct/reverse Action Selection Function)

■When control output is not being executed

The temperature control module detects an error because the temperature rises even while control output is not being executed under the following conditions:

- When input is disconnected
- When a contact point of an externally-operable device was welded

When the temperature does not fall by 2°C (°F) or lower within the set loop disconnection detection judgment time after the control output has reached the lower limit output limiter value, an alert is output. (The operation is reversed for a forward action.  Page 51 Direct/reverse Action Selection Function)

Setting method

Configure two settings to use the loop disconnection detection function.

■Setting the unit time to monitor the variation amount in the temperature process value (PV)

Configure the setting as follows.

 [Navigation window] ⇒ [Parameter] ⇒ Target module ⇒ [Module Parameter] ⇒ [Application Setting] ⇒ [Loop disconnection detection setting] ⇒ [Loop disconnection detection judgment time]

Point

When this function is not necessary, set 0 for "Loop disconnection detection judgment time" of "Loop disconnection detection setting" in "Application Setting".

■Setting a dead band

Set the non-alert area having the set value (SV) at the center (temperature width in which no loop disconnection is detected) to prevent accidental alerts of the loop disconnection detection.

When the temperature process value (PV) is within the loop disconnection detection dead band, an alert is not output even though the loop disconnection alert conditions have been satisfied.

Configure the setting as follows.

 [Navigation window] ⇒ [Parameter] ⇒ Target module ⇒ [Module Parameter] ⇒ [Application Setting] ⇒ [Loop disconnection detection setting] ⇒ [Loop disconnection detection dead band]

Point

When this function is not necessary, set 0 for "Loop disconnection detection dead band" of "Loop disconnection detection setting" in "Application Setting".

1.30 During AT Loop Disconnection Detection Function

This function detects loop disconnections during AT (auto tuning). A channel that does not follow the control can be detected by using this function. An error channel can be detected faster than the set time in which the auto tuning ends in failure. The auto tuning continues even while a loop disconnection detection alert has been issued.

For details on the loop disconnection detection function, refer to the following.

 Page 88 Loop Disconnection Detection Function

Point

- This function is enabled even while the peak current suppression function or the simultaneous temperature rise function is being used.
- The loop disconnection detection dead band setting is disabled for the loop disconnection detection during AT. (There is no dead band.)

Conditions to start the during AT loop disconnection detection function

- "Valid" has been set for "During AT loop disconnection detection function is enabled/disabled" of "Auto tuning setting" in "Application Setting".
- A value other than 0 has been set for "Loop disconnection detection judgment time" of "Loop disconnection detection setting" in "Application Setting".
- The control mode is the standard control. (CH3 and CH4 of the mix control can be used)

The during AT loop disconnection detection function does not work when the above conditions are not satisfied. An error or alarm does not occur even though the conditions are not satisfied.

■Setting method

1. Set a value other than 0 for "Loop disconnection detection judgment time". It takes time before the temperature starts rising due to the dead time of a controlled object. Consider the dead time of each controlled object and set the value.

 [Navigation window] ⇒ [Parameter] ⇒ Target module ⇒ [Module Parameter] ⇒ [Application Setting] ⇒ [Loop disconnection detection setting] ⇒ [Loop disconnection detection judgment time]

2. Set the following item to "Valid".

 [Navigation window] ⇒ [Parameter] ⇒ Target module ⇒ [Module Parameter] ⇒ [Application Setting] ⇒ [Auto tuning setting] ⇒ [During AT loop disconnection detection function is enabled/disabled]

3. Execute the auto tuning. ( Page 38 Procedure of auto tuning)

Ex.

For the control in which the temperature rises by 200°C for 40 minutes

It takes approximately 24 seconds to raise the temperature by 2°C. It takes time before the temperature starts rising due to the dead time of a controlled object. Set the time calculated by adding 24 seconds and the dead time of the controlled object.

For example, when the total dead time is 6 seconds, set 30 for "Loop disconnection detection judgment time" of "Loop disconnection detection setting" in "Application Setting".

Operation to be executed when an alert occurs or does not occur

When a loop disconnection detection alert is issued, 'CH1 Alert flag' (XC) and CH1 Loop disconnection detection (Un\G401, b13) turn on, and CH1 Loop disconnection detection (alarm code: 089□H) is stored in 'Latest alarm code' (Un\G3). (Page 146 List of Alarm Codes)

When a loop disconnection detection alert is not issued and the auto tuning is completed successfully, "Loop disconnection detection judgment time" of "Loop disconnection detection setting" in "Application Setting" is automatically updated to the value calculated by the auto tuning.

Point

When a loop disconnection alert occurs, there may be an error in the control loop. Thus, even though the auto tuning has been completed successfully, check the control loop and if the loop disconnection detection judgment time of the auto tuning is appropriate.

Clearing the alert status

When one of the following conditions is satisfied, 'CH1 Alert flag' (XC) and CH1 Loop disconnection detection (Un\G401, b13) turn off.

- 'CH1 PID control forced stop command' (YC) is turned off and on.
- 'Setting/operation mode command' (Y1) is turned on and off and the mode shifts to the setting mode.
- A manipulated value (MV) becomes greater than the lower limit output limiter value and smaller than the upper limit output limiter value.
- The value 0 is set for "Loop disconnection detection judgment time" of "Loop disconnection detection setting" in "Application Setting".
- MAN (1) has been set for 'CH1 AUTO/MAN mode shift' (Un\G518).
- "Disable" has been set for "During AT loop disconnection detection function is enabled/disabled" of "Auto tuning setting" in "Application Setting".

After executing the operations above, turn on and off 'Error reset command' (Y2) to clear the value in 'Latest alarm code' (Un\G3).

1.31 Peak Current Suppression Function

This function suppresses the peak current by automatically changing the values of the upper limit output limiter of each channel and dividing the timing of the transistor output. The timing can be divided into two to four parts.

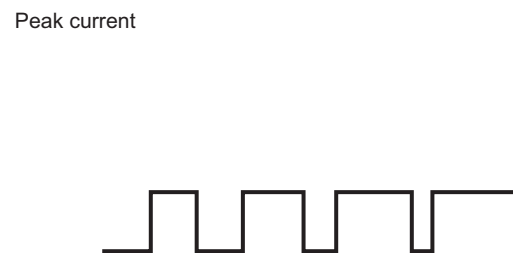
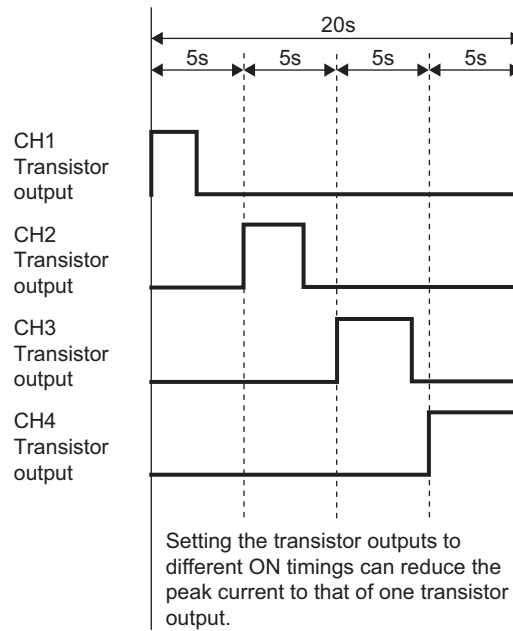
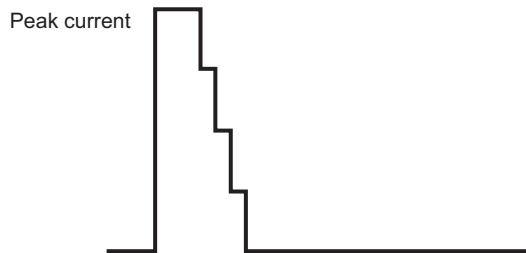
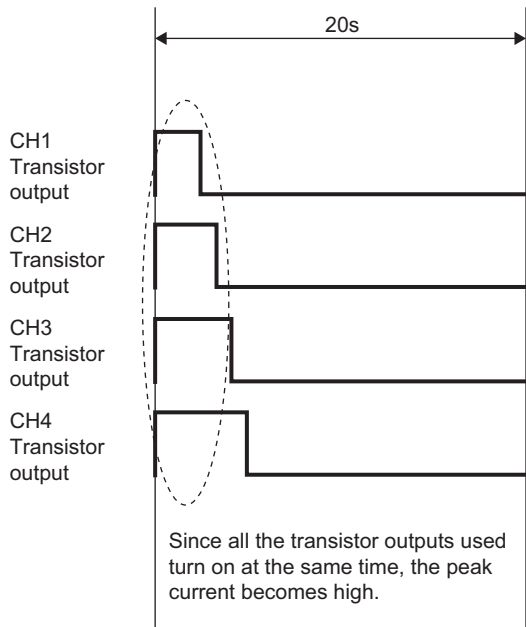

The number of divisions and upper limit output limiter

Configure the setting to divide the timing ("Peak current suppression control group setting" of "Peak current suppression setting" in "Application Setting") in the setting mode ("Setting/operation mode status" (X1): Off). Turn on and off 'Setting change command' (YB) to enable the setting. At the timing when the setting is enabled, "Upper limit output limiter" of "Limiter setting" in "Application Setting" is automatically set according to the number of divisions.

Number of divisions	"Upper limit output limiter" of "Limiter setting" in "Application Setting"
2	50.0%
3	33.3%
4	25.0%

"Lower limit output limiter" of "Limiter setting" in "Application Setting" is set to 0.0%.

The following shows the timing when the upper limit output limiter and lower limit output limiter are output by the peak current suppression function.

- At power-on
- When the CPU module is turned from STOP to RUN
- When the number of divisions is changed

Point

When using this function, set a single value for the control output cycles of target channels.

When the parameter settings of the channels are different, an error does not occur.

- "Control output cycle setting" of "Control basic parameters" in "Application Setting"

The module operates with the value (%) of "Upper limit output limiter" of "Limiter setting" in "Application Setting" that is automatically set when this function is used.

Ex.

Timing chart of when the timing is divided into four parts

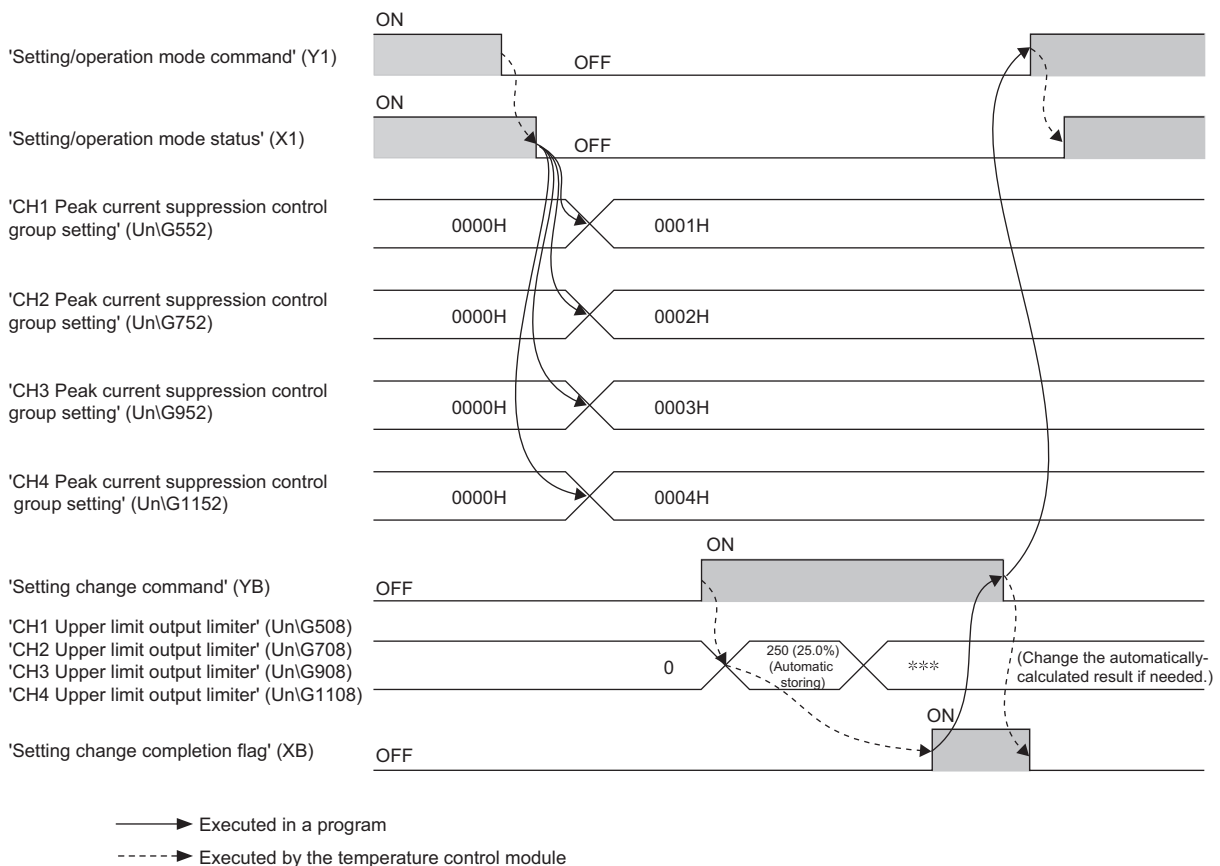

Examples of dividing timing

■ When the timing is divided into four parts

The following table shows two examples.

Example	Channel	Group
Example 1	CH1	Group 1
	CH2	Group 2
	CH3	Group 3
	CH4	Group 4
Example 2	CH1	Group 1
	CH2	Group 2
	CH3	Not divided
	CH4	Group 4

The following figure shows the relation between each group and the value (%) of "Upper limit output limiter" of "Limiter setting" in "Application Setting".

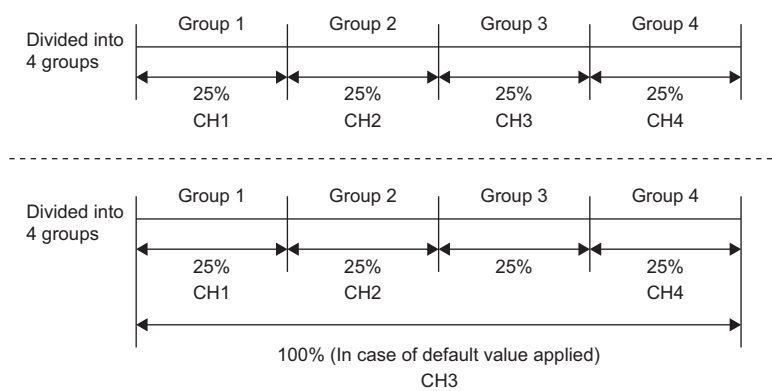

In Example 2, the maximum number of groups is four; therefore, the timing is divided into four parts. Because no channel has been set for Group 3, no channel starts transistor output at the timing of Group 3.

■When the timing is divided into three parts

The following table shows two examples.

Example	Channel	Group
Example 1	CH1	Group 1
	CH2	Group 2
	CH3	Group 2
	CH4	Group 3
Example 2	CH1	Group 1
	CH2	Group 2
	CH3	Group 3
	CH4	Not divided

The following figure shows the relation between each group and the value (%) of "Upper limit output limiter" of "Limiter setting" in "Application Setting".

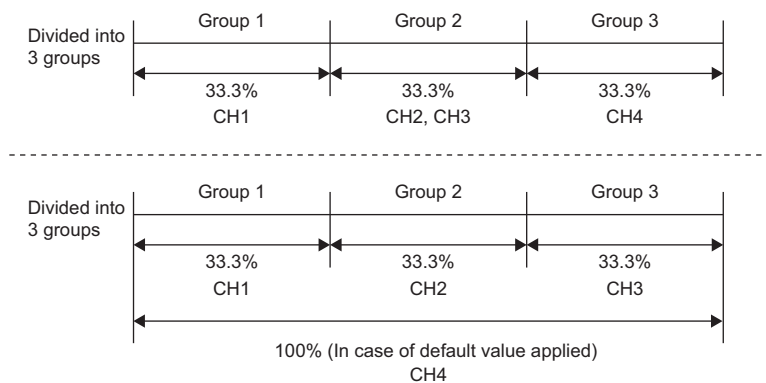

■When the timing is divided into two parts

The following table shows two examples.

Example	Channel	Group
Example 1	CH1	Group 1
	CH2	Group 1
	CH3	Group 2
	CH4	Group 2
Example 2	CH1	Group 1
	CH2	Group 2
	CH3	Not divided
	CH4	Not divided

The following figure shows the relation between each group and the value (%) of "Upper limit output limiter" of "Limiter setting" in "Application Setting".

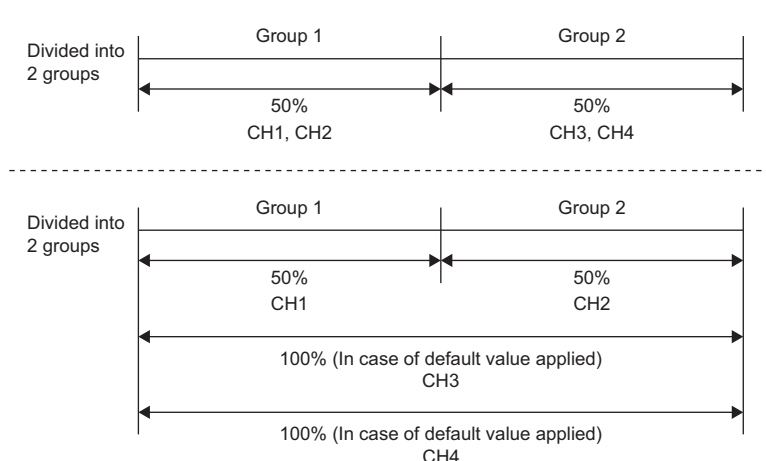

Setting method

Configure the setting as follows.

 [Navigation window] ⇒ [Parameter] ⇒ Target module ⇒ [Module Parameter] ⇒ [Application Setting] ⇒ [Peak current suppression setting] ⇒ [Peak current suppression control group setting]

1.32 Simultaneous Temperature Rise Function

This function allows several loops to reach the set value (SV) at the same time. Simultaneous temperature rise can be executed on up to two groups separately by setting a group of the channels where temperatures rise at the same time. This function is good for controlled objects in which the temperature rise have to be completed at the same time. Aligning the temperature rise completion time enables an even control of temperatures without partial burning or partial heat expansion. In addition, the channel that has reached the set value (SV) first does not need to be kept warm at the set value (SV) until the last channel reaches the set value (SV), leading to energy saving.

Ex.

Comparison of the cases where the simultaneous temperature rise function is used and the function is not used in CH1

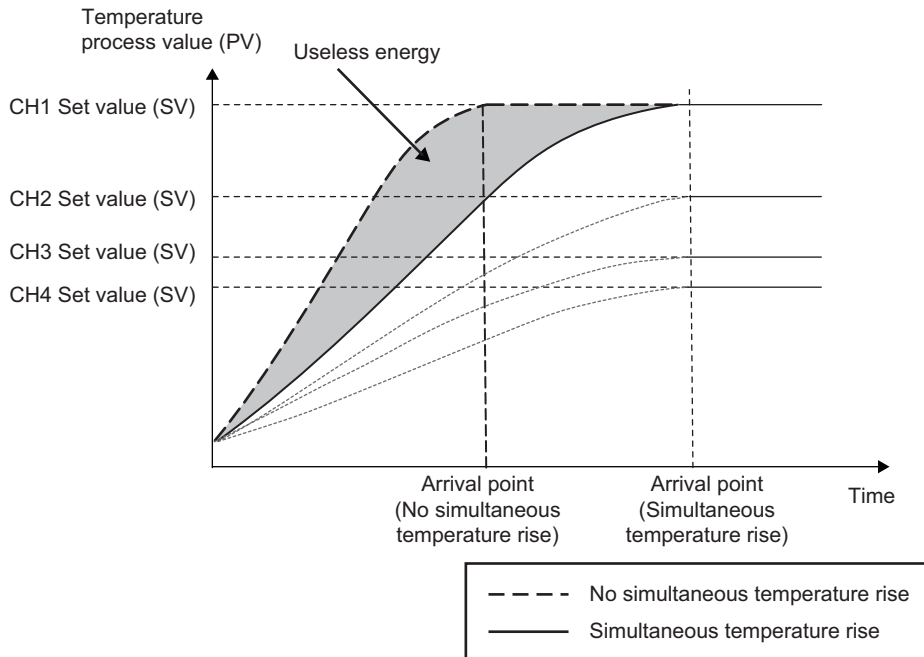

Operation of the simultaneous temperature rise function

Among the channels that have satisfied the condition to start the simultaneous temperature rise, the channel in which the temperature reaches the set value (SV) last is used as a standard when the simultaneous temperature rise function is started. The temperature of the other channels rise following the temperature of the standard channel. The standard channel is determined based on the simultaneous temperature rise parameter and the deviation (E).

Ex.

When all channels have been selected for Group 1

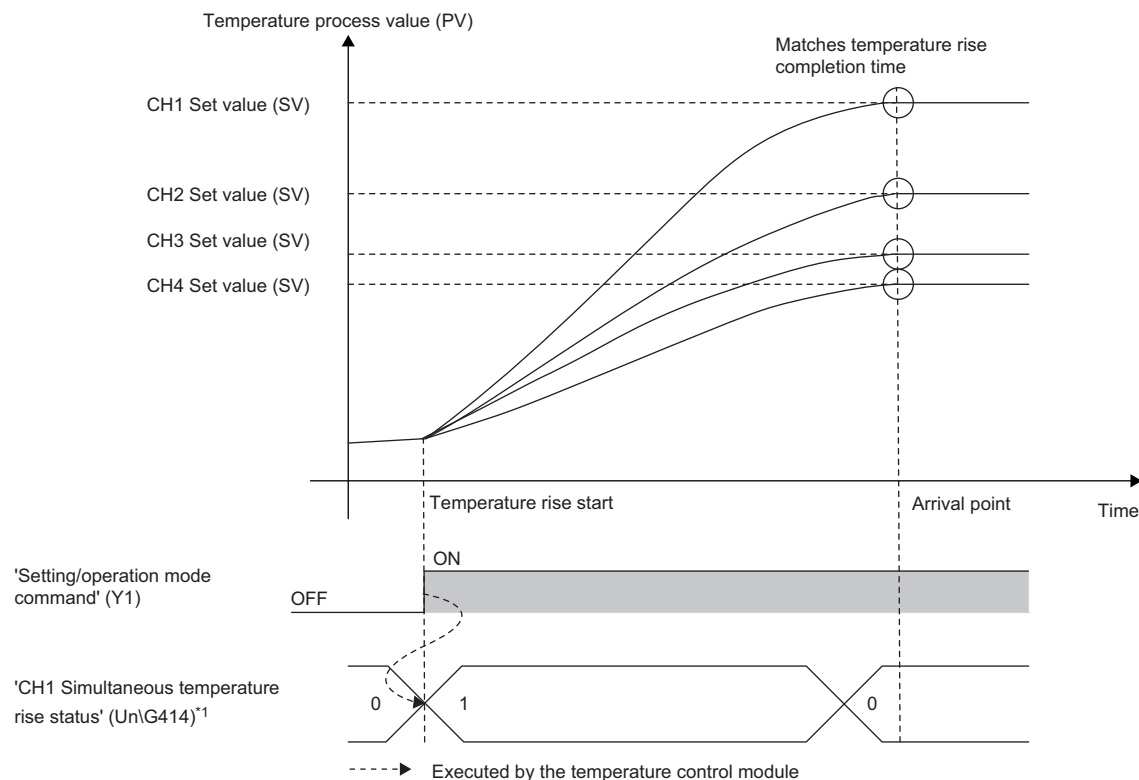

*1 Although Simultaneous temperature rise in process (1) is set at the start of the simultaneous temperature rise, Simultaneous temperature rise not in process (0) is set before the completion of the temperature rise.

Ex.

When channels are divided as follows

- CH1, CH2: Group 1
- CH3, CH4: Group 2

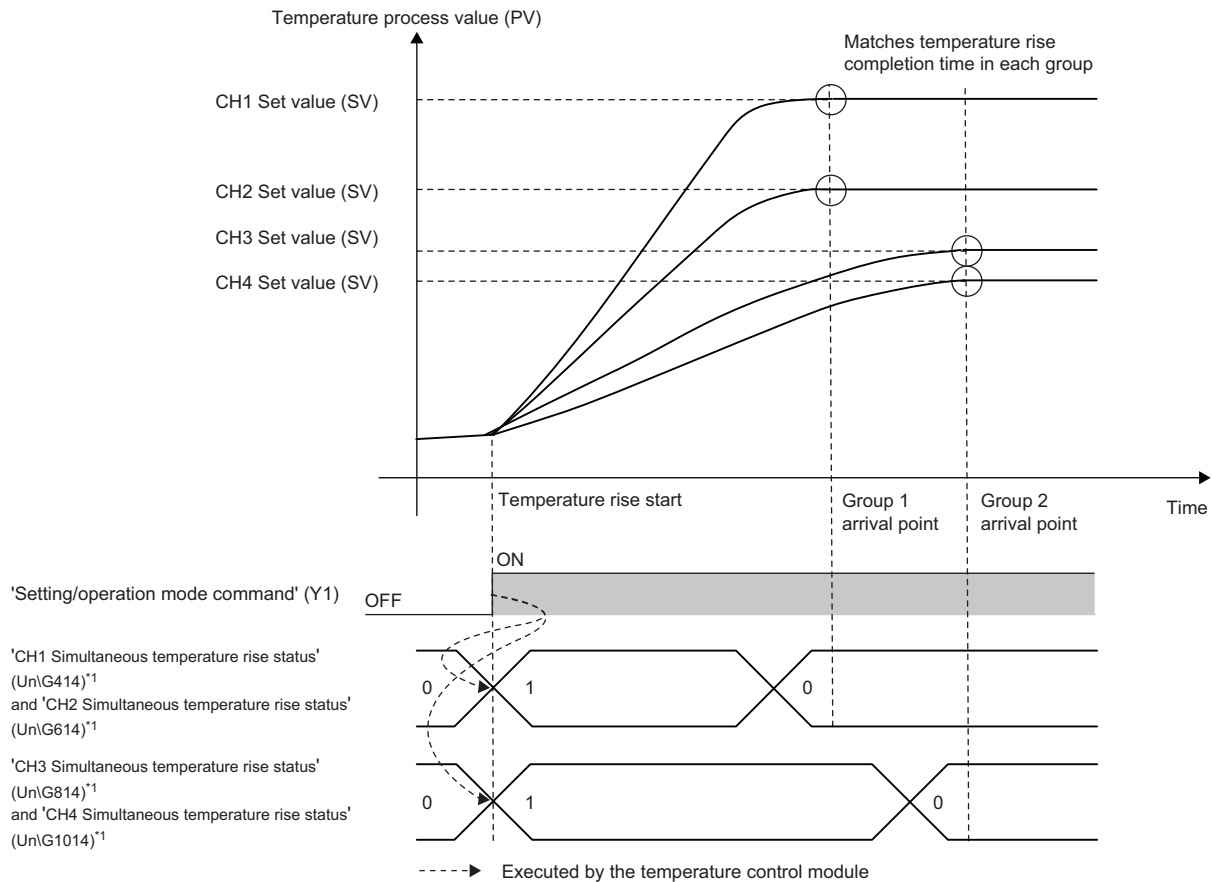

*1 Although Simultaneous temperature rise in process (1) is set at the start of the simultaneous temperature rise, Simultaneous temperature rise not in process (0) is set before the completion of the temperature rise.

Point

- When the mode is changed from the operation mode to the setting mode ('Setting/operation mode command' (Y1) is turned on and off) during the simultaneous temperature rise, the control stops. In addition, 'CH1 Simultaneous temperature rise status' (UnG414) changes from Simultaneous temperature rise in process (1) to Simultaneous temperature rise not in process (0). (An error does not occur.)
- When the simultaneous temperature rise function is executed, the setting variation rate limiter cannot be used.

Conditions to execute the simultaneous temperature rise function

When all of the following conditions are satisfied, the simultaneous temperature rise function can be executed.

- The control is started
- The set value (SV) is larger than the temperature process value (PV).
- "Standard Control" has been selected for "Control mode selection" in "Base Setting" (This function cannot be executed in the heating-cooling control).
- The simultaneous temperature rise parameter has been determined (or has been set) and a value other than 0 (default value) has been set.

When a value smaller than 100% is set for the following parameter, temperature rise may not be completed at the same time.

- "Upper limit output limiter" of "Limiter setting" in "Application Setting"

Setting method (dividing channels into groups)

Configure the setting as follows.

[Navigation window] ⇒ [Parameter] ⇒ Target module ⇒ [Module Parameter] ⇒ [Application Setting] ⇒ [Simultaneous temperature rise setting] ⇒ [Simultaneous temperature rise group setting]

Simultaneous temperature rise parameter

The simultaneous temperature rise parameter is the values in the following two buffer memory areas.

- 'CH1 Simultaneous temperature rise gradient data' (Un\G554)
- 'CH1 Simultaneous temperature rise dead time' (Un\G555)

■Automatic calculation

The simultaneous temperature rise parameter can be automatically calculated using the following two methods:

- Simultaneous temperature rise AT
- Simultaneous temperature rise parameter setting with self-tuning

Point

When the setting of "Peak current suppression control group setting" of "Peak current suppression setting" in "Application Setting" is changed after the simultaneous temperature rise parameter has been calculated, the intended control may not be executed. In that case, calculate the simultaneous temperature rise parameter again. For details on the peak current suppression function, refer to the following.

☞ Page 92 Peak Current Suppression Function

Simultaneous temperature rise AT

PID constants and the simultaneous temperature rise parameter are calculated. The waveform upon execution is the same as that for the auto tuning function.

For details on the auto tuning function, refer to the following.

☞ Page 35 Auto Tuning Function

■Procedure for executing the simultaneous temperature rise AT

The following shows the procedure for executing simultaneous temperature rise AT.

1. Set "AT for Simultaneous Temperature Rise" for "Simultaneous temperature rise AT mode setting".

[Navigation window] ⇒ [Parameter] ⇒ Target module ⇒ [Module Parameter] ⇒ [Application Setting] ⇒ [Simultaneous temperature rise setting] ⇒ [Simultaneous temperature rise AT mode setting]

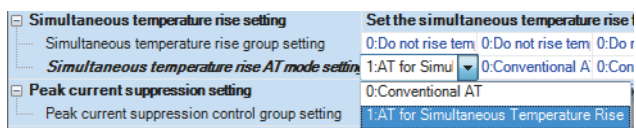

2. Turn off and on 'CH1 Auto tuning command' (Y4).
3. Shift the mode to the operation mode (turn off and on 'Setting/operation mode command' (Y1).

■ Operation of the simultaneous temperature rise AT

When the function is executed, the temperature control module operates as follows.

Operation of the temperature control module	
1	'CH1 Auto tuning status' (X4) turns on. The normal auto tuning is executed and the simultaneous temperature rise parameter is calculated.
2	A calculation value is stored in the buffer memory when the simultaneous temperature rise parameter has been properly calculated. CH1 AT simultaneous temperature rise parameter calculation completion (Un\G413, b0) is turned on. After the auto tuning is completed, 'CH1 Auto tuning status' (X4) turns off and the module is shifted to the PID control.

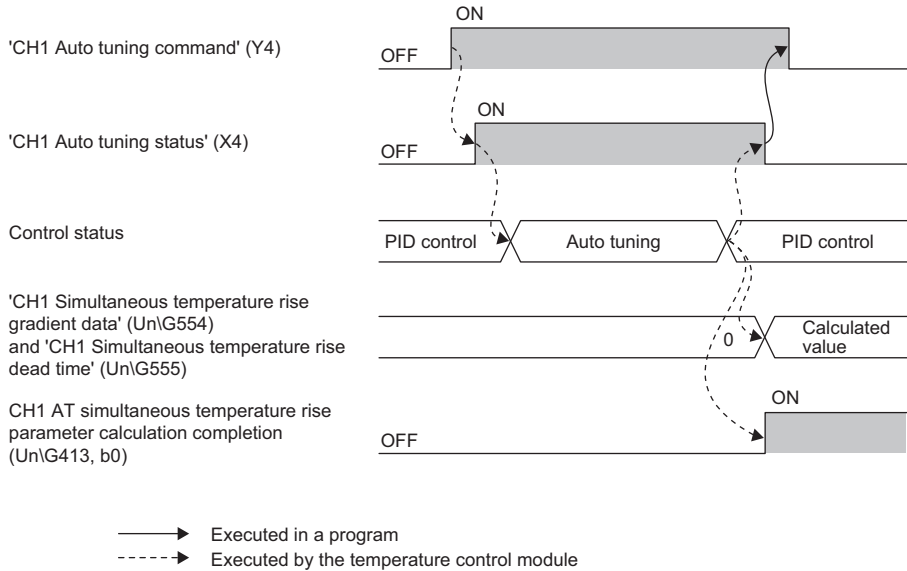

■ Conditions to execute the simultaneous temperature rise AT

When all of the following conditions are satisfied after the operations are executed, the simultaneous temperature rise parameter is calculated.

- The PID control has been set. (All of the proportional band (P), integral time (I), and derivative time (D) are not 0.)
- The temperature process value (PV) has been stable for two minutes or longer just before the simultaneous temperature rise AT is executed.
- The temperature process value (PV) just before the simultaneous temperature rise AT is executed is within the temperature measuring range. When the temperature process value (PV) goes outside the range after the simultaneous temperature rise AT is executed, the auto tuning ends in failure. (Page 43 When the auto tuning ends in failure)
- "Output Change Amount Limiter" of "Limiter setting" in "Application Setting" has been set to 0.

When all the conditions described above are not satisfied, the simultaneous temperature rise parameter is not calculated.

Only PID constants are calculated.

The following shows how the temperature control module operates when the simultaneous temperature rise AT has not been executed.

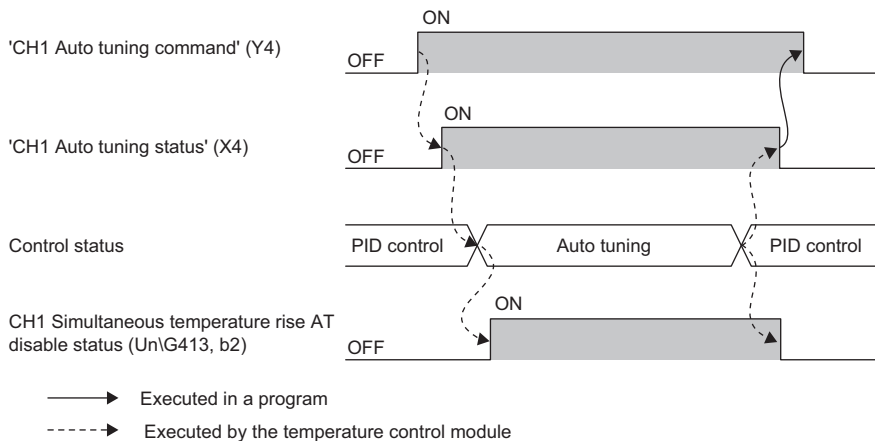

The temperature control module turns on CH1 Simultaneous temperature rise AT disable status (Un\G413, b2). With 'CH1 Auto tuning status' (X4) on, the module executes the same processing as the normal auto tuning.

■When the simultaneous temperature rise parameter cannot be calculated

The simultaneous temperature rise parameter is not calculated under the following conditions:

- When the maximum ramp is not determined
- When the output saturation time is short

The temperature control module turns on CH1 AT simultaneous temperature rise parameter calculation error status (Un\G413, b1).

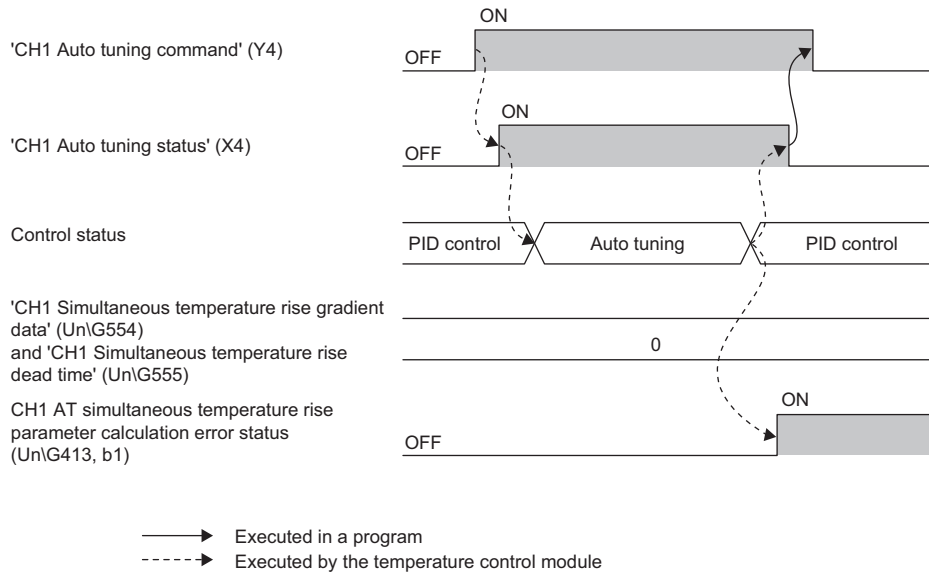

Simultaneous temperature rise parameter setting with self-tuning

The control response at the temperature rise is constantly monitored during self-tuning and the simultaneous temperature rise parameter is calculated based on the characteristics of a controlled object.

For details on the self-tuning function, refer to the following.

☞ Page 44 Self-tuning Function

■Operation with the simultaneous temperature rise parameter setting with self-tuning

The temperature control module operates as follows.

Operation of the temperature control module	
1	When the self-tuning has been normally started, 'CH1 Auto tuning status' (X4) turns on and the simultaneous temperature rise parameter is calculated.
2	A calculation value is stored in the buffer memory when the simultaneous temperature rise parameter has been properly calculated. The module turns on CH1 Simultaneous temperature rise parameter correction status (Un\G411, b1) and turns off 'CH1 Auto tuning status' (X4), and the control is shifted to the PID control.

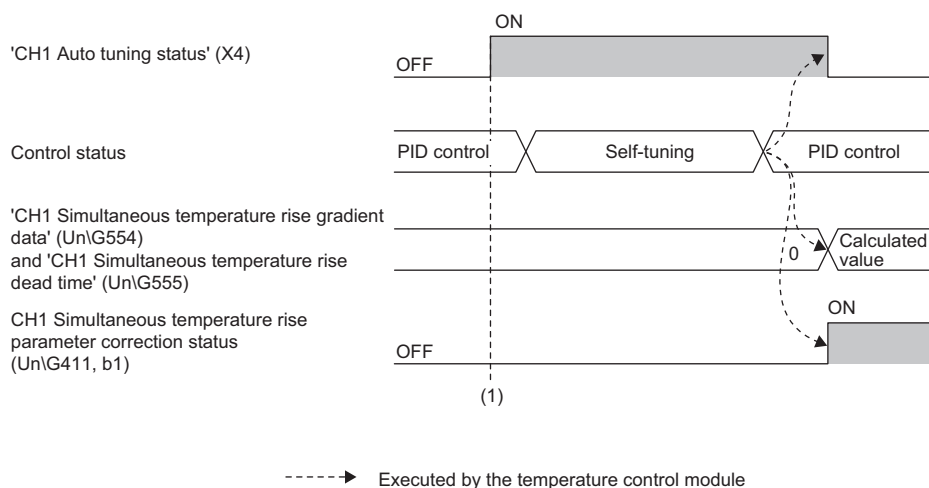

(1) When the temperature control starts, the set value (SV) is changed, or vibration is detected

■Conditions to execute the simultaneous temperature rise parameter setting with self-tuning

The conditions are the same as the ones for the starting ST. (☞ Page 46 Conditions for execution)

When the self-tuning cannot be started, the temperature control module operates as follows with the PID control continued.

- CH1 Self-tuning disable status (Un\G411, b8) is turned on.

The following shows how the temperature control module operates when the self-tuning is not executed.

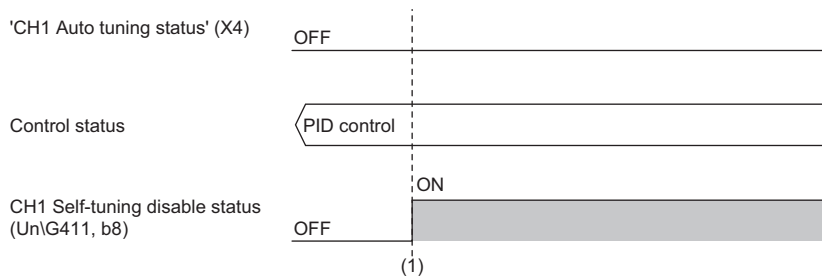

(1) When the temperature control starts, the set value (SV) is changed, or vibration is detected

■When the simultaneous temperature rise parameter cannot be calculated

The simultaneous temperature rise parameter is not calculated under the following conditions:

- When the maximum ramp is not determined
- When the output saturation time is short

The temperature control module turns on CH1 Simultaneous temperature rise parameter error status (Un\G411, b9).

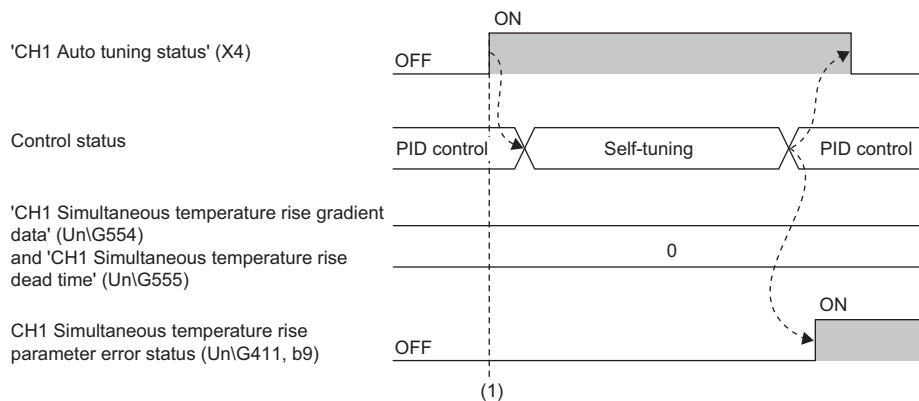

-----> Executed by the temperature control module

(1) When the temperature control starts, the set value (SV) is changed, or vibration is detected

Point

To turn off CH1 Simultaneous temperature rise parameter error status (Un\G411, b9), set the following.

- Set "Do Not Run the ST" for "Self-tuning setting" in "Application Setting".

To calculate the simultaneous temperature rise parameter, execute the self-tuning again. However, execute it after the temperature has dropped.

■Stopping of the calculation of the simultaneous temperature rise parameter

The optimum simultaneous temperature rise parameter may not be able to be calculated depending on the characteristics of a controlled object. In addition, the temperature control module stops the calculation when the self-tuning has not been completed with errors. For the conditions in which the self-tuning is completed with errors, refer to the following.

☞ Page 49 Conditions in which the self-tuning ends in failure

■How to set the simultaneous temperature rise parameter with self-tuning

Select one of the following two settings for "Self-tuning setting" in "Application Setting".

- 2: Starting ST (Simultaneous temperature rise parameter only)
- 3: Starting ST (PID Constant and simultaneous temperature rise parameter)

☞ [Navigation window] ⇒ [Parameter] ⇒ Target module ⇒ [Module Parameter] ⇒ [Application Setting] ⇒ [Self-tuning setting]

Operation of when the simultaneous temperature rise parameter is calculated

■ When the simultaneous temperature rise AT is started before the simultaneous temperature rise parameter is calculated with self-tuning

The simultaneous temperature rise parameter is not calculated neither with self-tuning nor auto tuning. PID constants are changed.

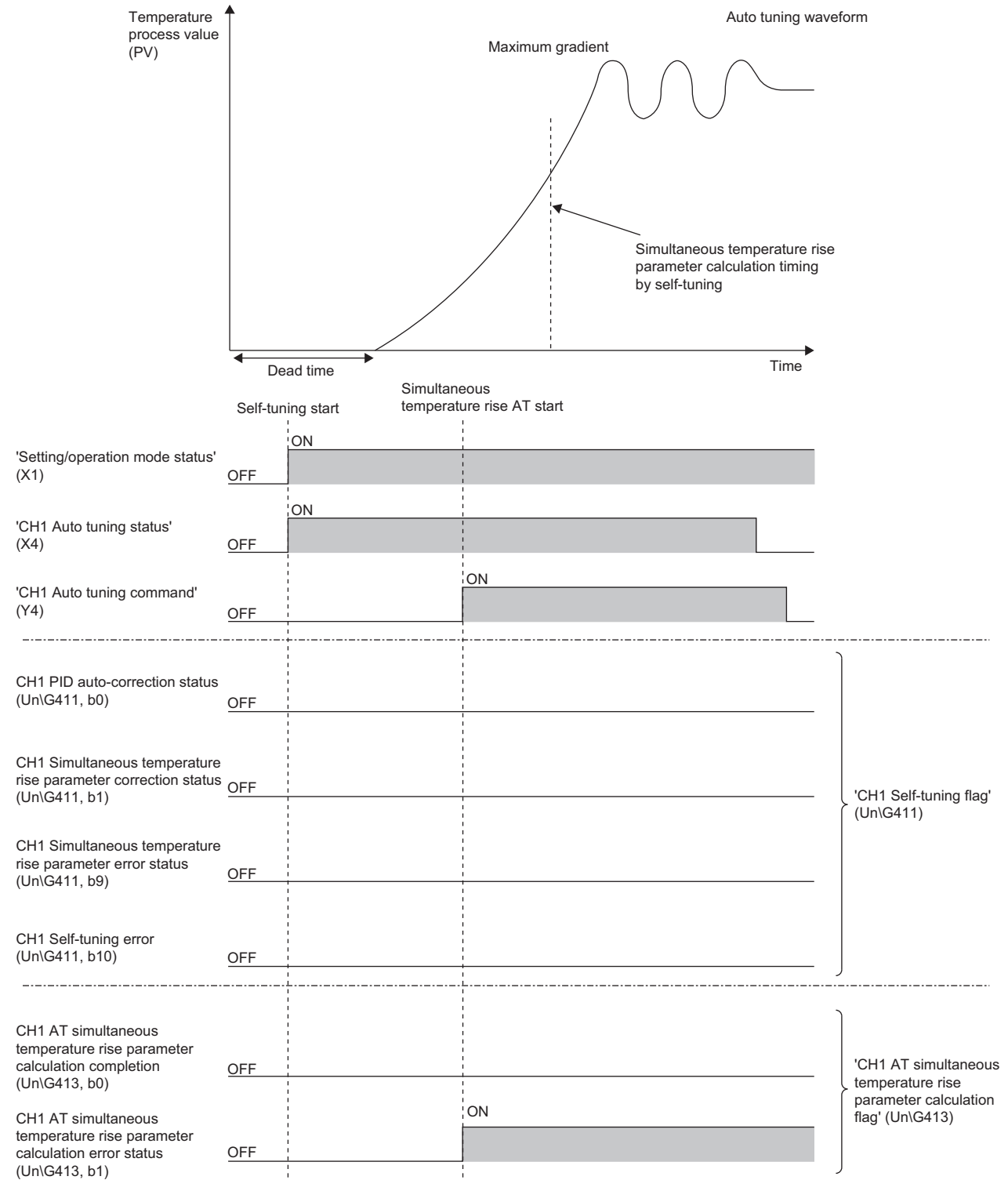

■ When the simultaneous temperature rise AT is started after the simultaneous temperature rise parameter is calculated with self-tuning

The simultaneous temperature rise parameter calculated with the self-tuning is enabled, and PID constants are changed by the auto tuning.

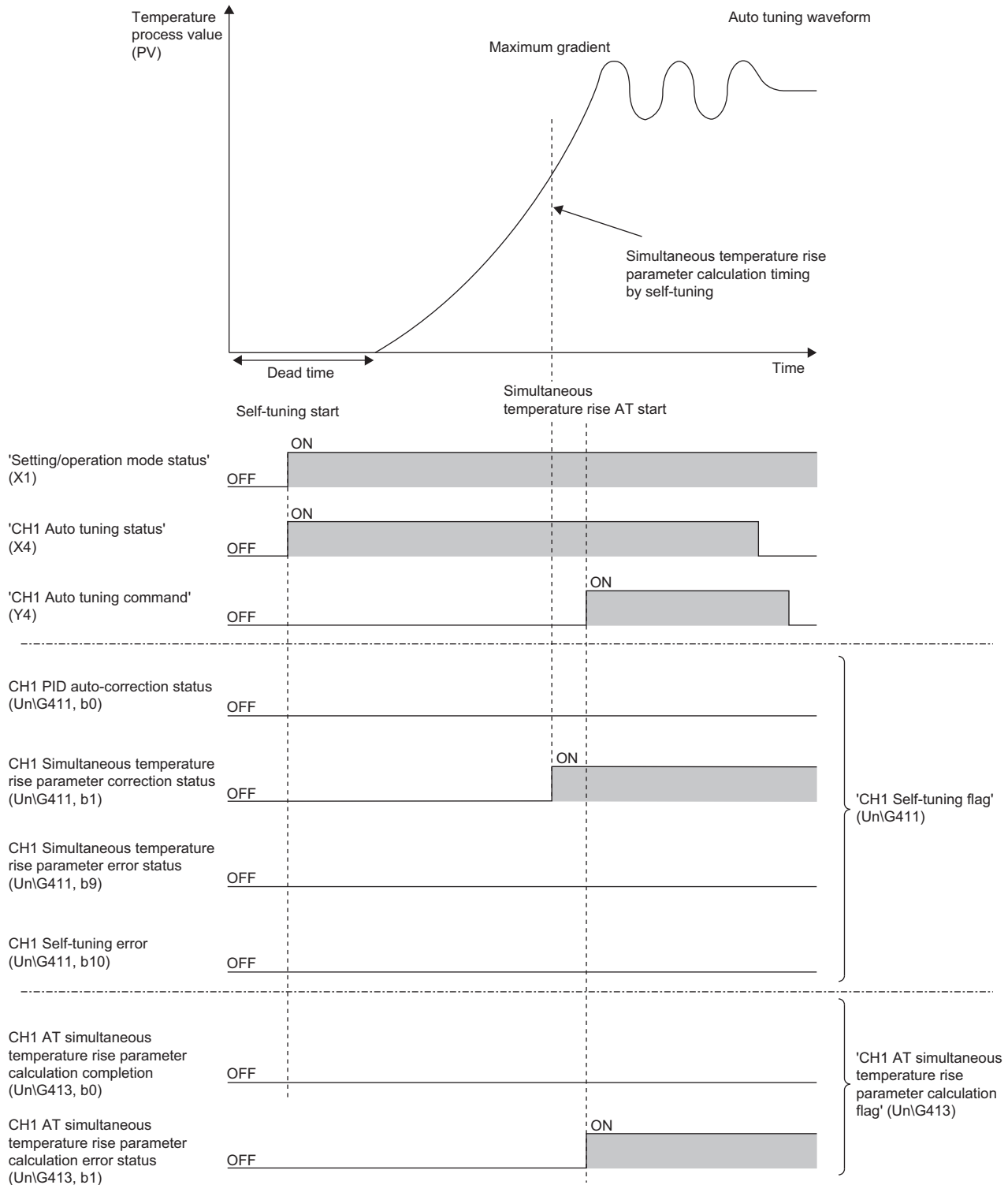

■When 'CH1 Auto tuning command' (Y4) is turned off and on in the setting mode and the mode is shifted to the operation mode

After the mode is shifted to the operation mode ('Setting/operation mode command' (Y1) is turned off and on), the simultaneous temperature rise parameter and PID constants are changed by the auto tuning.

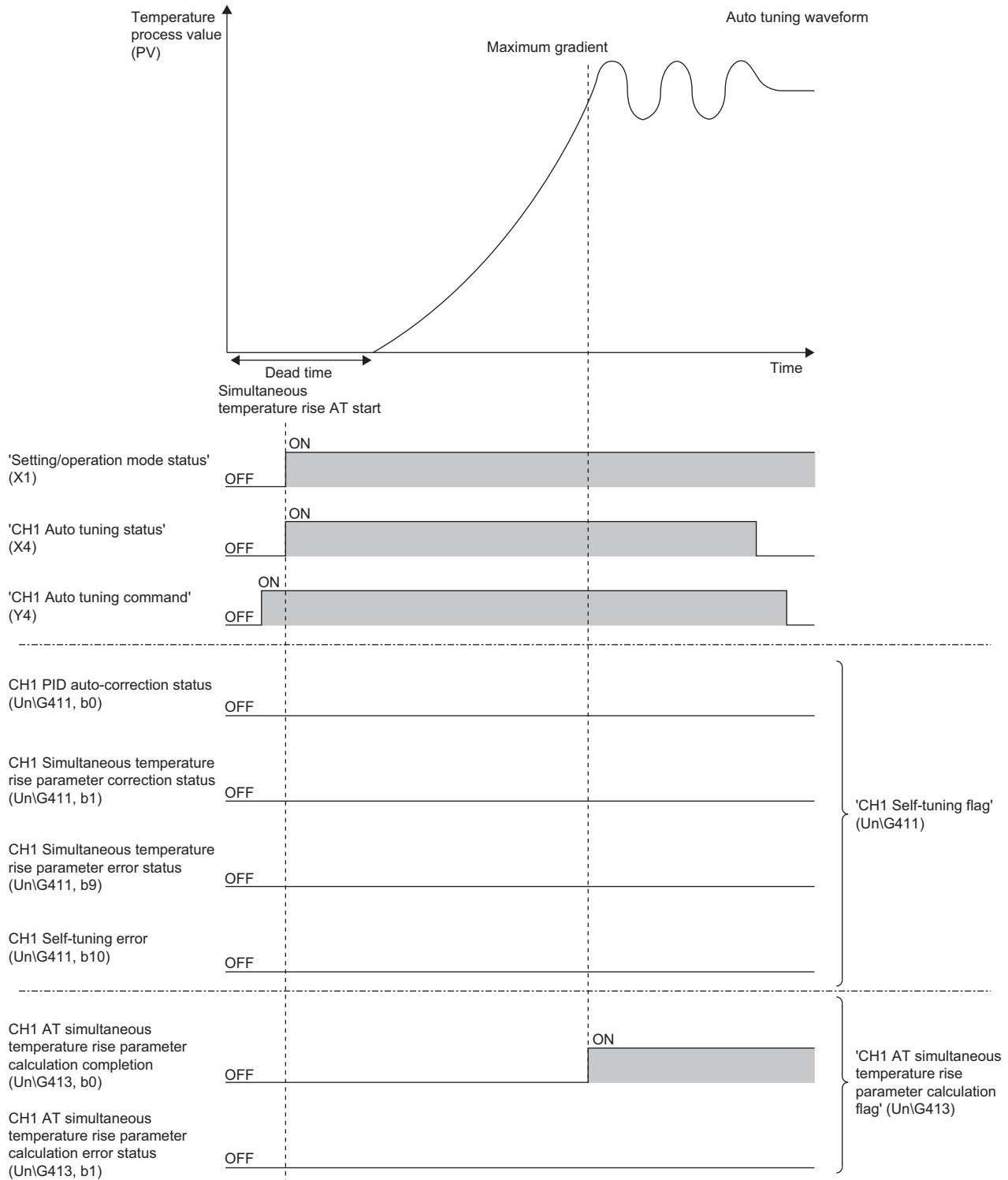

■When the auto tuning is started with the temperature process value (PV) that is within the stable judgment width (1°C (°F)) after the mode has shifted from the setting mode to the operation mode

Until the temperature process value (PV) goes outside the stable judgment width (1°C (°F)), the data measured after the mode has been shifted to the operation mode ('Setting/operation mode command' (Y1) is turned off and on) can be used. Thus, the simultaneous temperature rise parameter can be calculated by the auto tuning.

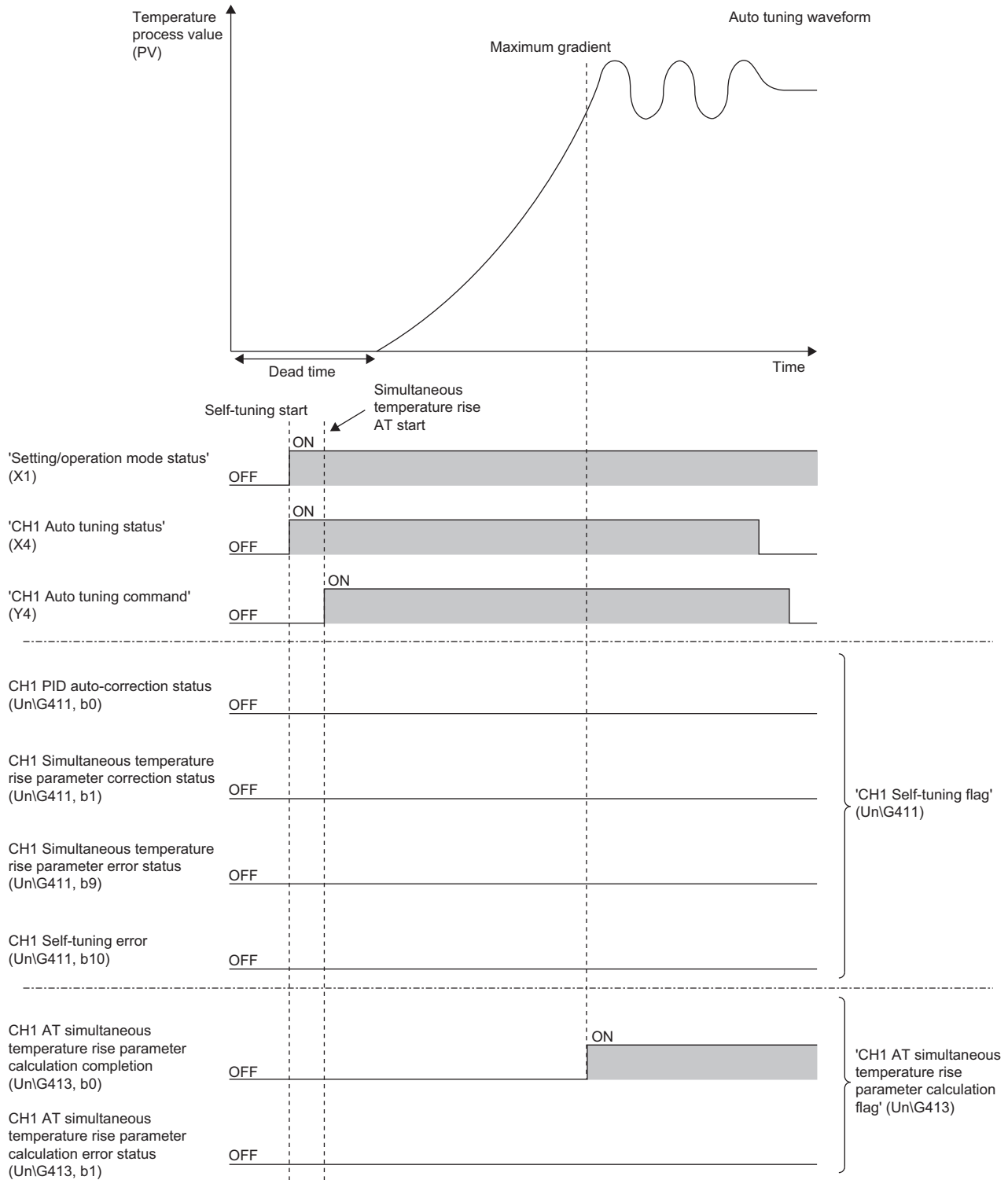

1.33 Inter-module Link Function

The inter-module link function has the following two functions.

- Inter-module peak current suppression function
- Inter-module simultaneous temperature rise function

These functions control temperatures with multiple temperature control modules.

The inter-module link function can be used between the temperature control modules having the same control CPU.

Inter-module peak current suppression function

The peak current is suppressed among the temperature control modules.

Up to 64 modules can be divided into 5 groups to suppress the peak current.

Setting a channel with a large heater capacity and the one with a small heater capacity in one group among the temperature control modules can suppress the scale of the power supply facility.

Compared to the peak current suppression with one module, the scale of the power supply facility can be more suppressed because the current is controlled through an entire system.

Not using the inter-module peak current suppression function

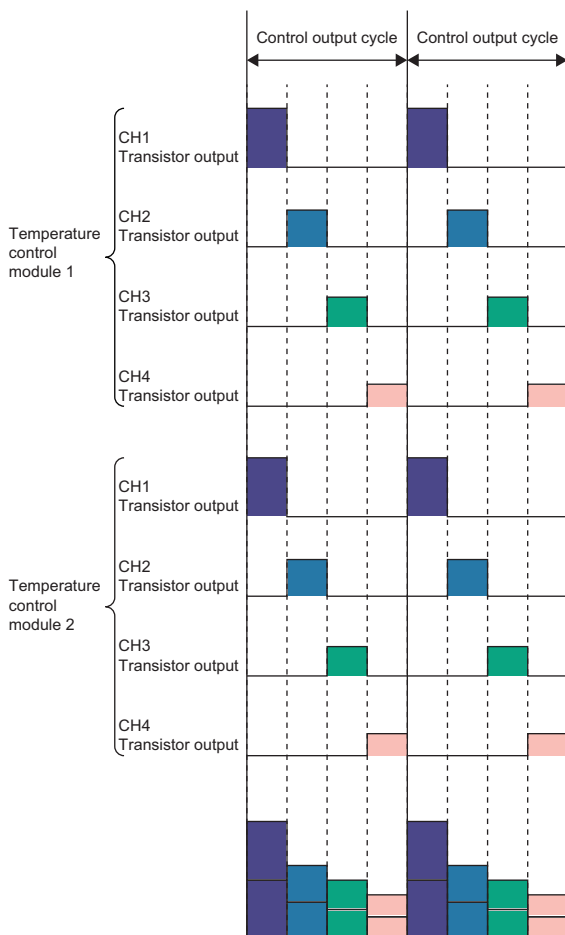

Using the inter-module peak current suppression function

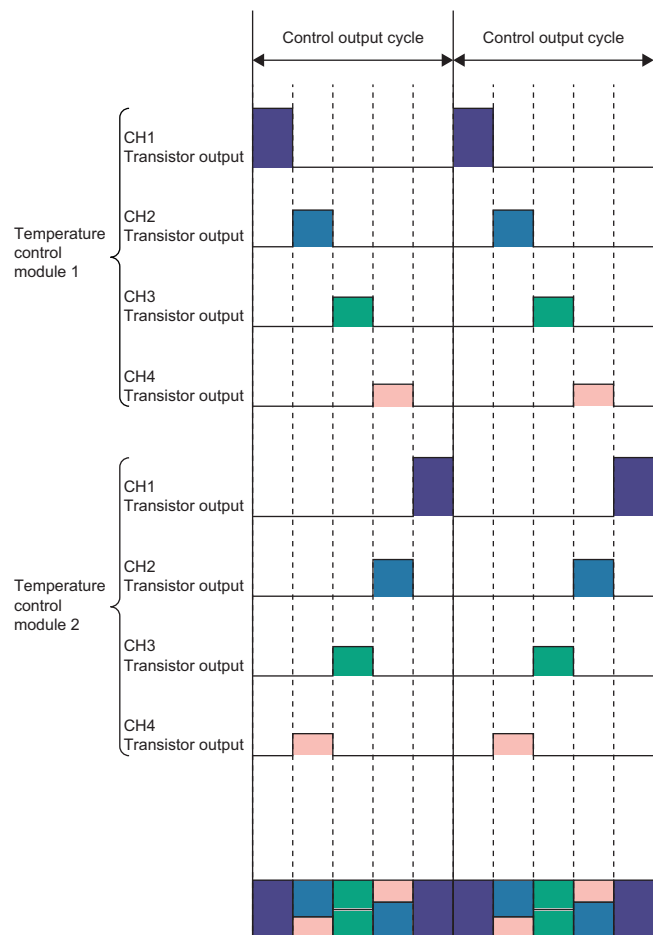

Setting method

The following shows the setting method.

1. Set "Peak current suppression function enable/disable between multiple module" to "Enable".

 [Navigation window] ⇒ [Parameter] ⇒ Target module ⇒ [Module Parameter] ⇒ [Base Setting] ⇒ [Multiple module interaction function] ⇒ [Peak current suppression function enable/disable between multiple module]

2. Set only one module of all the temperature control modules that use the inter-module peak current suppression function to "Master" in "Peak current suppression function master/slave selection between multiple module".

3. Set the number of divisions in "Peak current suppression control group setting".

 [Navigation window] ⇒ [Parameter] ⇒ Target module ⇒ [Module Parameter] ⇒ [Application Setting] ⇒ [Peak current suppression setting] ⇒ [Peak current suppression control group setting]

Point

For this function, no errors occur even though different values are set for the control output cycles for each channel. This function operates according to the value automatically set by the control group setting. Thus, set a single value for the control output cycles of target channels.

Starting the control

Turn off and on 'Setting/operation mode command' (Y1) of the modules to execute the inter-module peak current suppression function in the same scan.

Start the control at the timing when 'Inter-module peak current suppression function state monitor' (Un\G2100) is changed to In execution (1).

"Upper limit output limiter" of "Limiter setting" in "Application Setting" for CH1 is set to one of the following values according to the number of divisions.

"Lower limit output limiter" of "Limiter setting" in "Application Setting" is set to 0 (0.0%).

- When the value is divided into two parts: 500 (50.0%)
- When the value is divided into three parts: 333 (33.3%)
- When the value is divided into four parts: 250 (25.0%)
- When the value is divided into five parts: 200 (20.0%)

To change the output limiter value after the startup of the control, set a value with a program.

Inter-module simultaneous temperature rise function

The simultaneous temperature rise is executed among the temperature control modules.

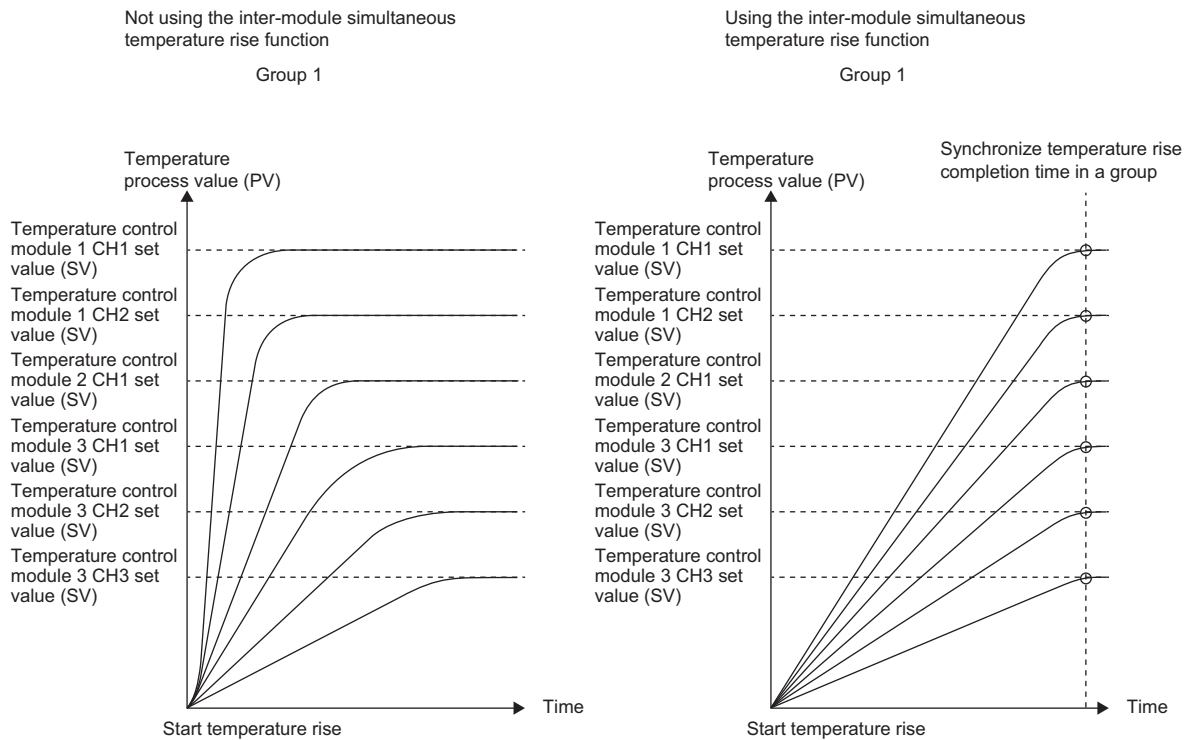
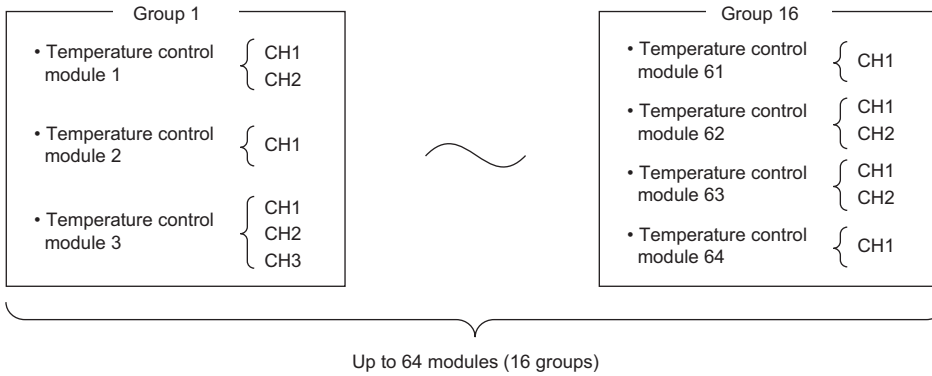

Up to 64 modules can be divided into 16 groups to execute the simultaneous temperature rise.

Compared to the simultaneous temperature rise with one module, the energy is effectively saved because the time taken for the temperature rise can be adjusted through an entire system.



Setting method

The following shows the setting method.

- 1.** Set "Simultaneous temperature rise function enable/disable between multiple module" to "Enable".
 [Navigation window] ⇨ [Parameter] ⇨ Target module ⇨ [Module Parameter] ⇨ [Base Setting] ⇨ [Multiple module interaction function] ⇨ [Simultaneous temperature rise function enable/disable between multiple module]
- 2.** Set only one module of all the temperature control modules that use the inter-module simultaneous temperature rise function to "Master" in "Simultaneous temperature rise function master/slave selection between multiple module".
- 3.** Set the values calculated by the auto tuning or self-tuning or the ones that users calculated for Simultaneous temperature rise dead time and Simultaneous temperature rise gradient data.
- 4.** Set groups in "Simultaneous temperature rise group setting". The inter-module simultaneous temperature rise function is not executed to the channel that has been set to "Do not rise temperature simultaneously".
 [Navigation window] ⇨ [Parameter] ⇨ Target module ⇨ [Module Parameter] ⇨ [Application Setting] ⇨ [Simultaneous temperature rise setting] ⇨ [Simultaneous temperature rise group setting]
- 5.** Simultaneously turn off and on 'Setting/operation mode command' (Y1) of the temperature control modules that execute the inter-module simultaneous temperature rise.

1.34 Proportional Band Setting Function

This function can set the proportional bands (P) for heating and cooling individually. Different gradients can be set by using different proportional band (P) values in heating and cooling areas.

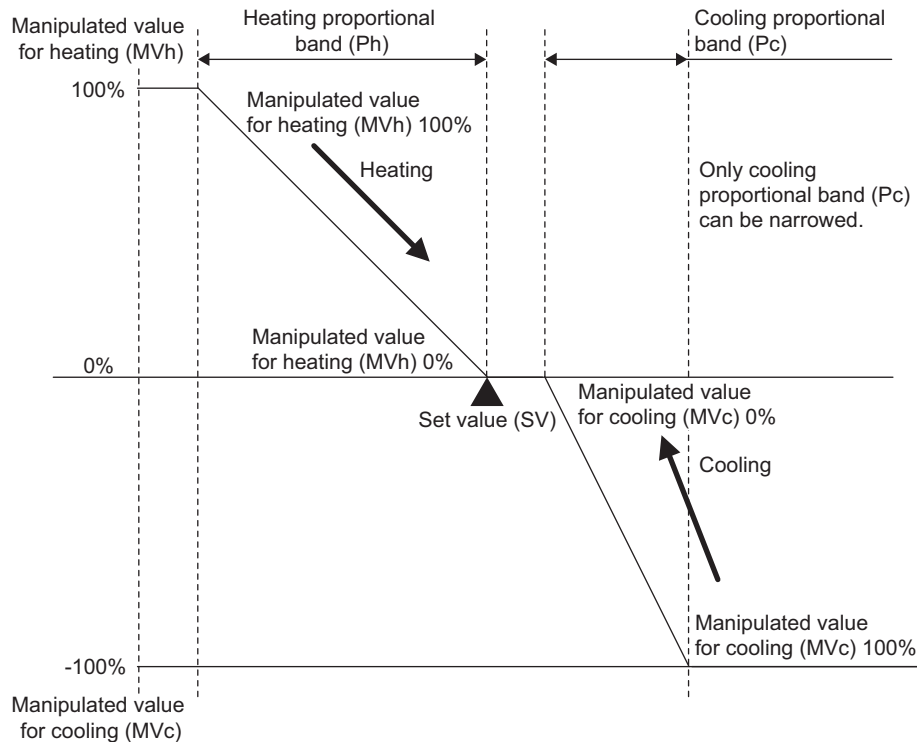

Setting method (in the R mode)

■For heating

Set a proportional band (P) in the following buffer memory area.

- 'CH1 Heating proportional band (Ph) setting' (Un\G431) (☞ Page 240 CH1 Heating proportional band (Ph) setting)

■For cooling

Set a proportional band (P) in the following buffer memory area.

- 'CH1 Cooling proportional band (Pc) setting' (Un\G439) (☞ Page 244 CH1 Cooling proportional band (Pc) setting)

Setting method (in the Q compatible mode)

■For heating

Configure the setting as follows.

- ☞ [Navigation window] ⇒ [Parameter] ⇒ Target module ⇒ [Module Parameter] ⇒ [Application Setting] ⇒ [Control basic parameters] ⇒ [Proportion Belt (P) Setting]

■For cooling

Configure the setting as follows.

- ☞ [Navigation window] ⇒ [Parameter] ⇒ Target module ⇒ [Module Parameter] ⇒ [Application Setting] ⇒ [Control basic parameters] ⇒ [Cooling proportional band (Pc) setting]

1.35 Disturbance Suppression Function

This function quickly damps the temperature change caused by disturbance while a temperature is in a stable state. To control the temperature fall (bottom) caused by the disturbance, execute the feed forward control (FF control). After the bottom control, the control mode returns to the normal PID control.

Restriction

The disturbance suppression function cannot be used in the position proportional control.

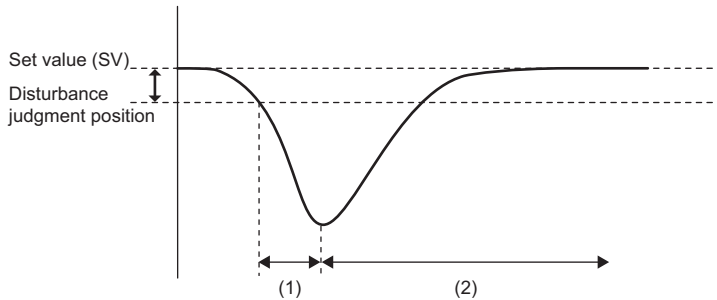

- (1) FF control
- (2) PID control

Ex.

This function is good to the devices to which a disturbance periodically is generated as shown below.

- Injection molding machine
- Semiconductor manufacturing equipment (plate for heating wafers)
- Packaging machine

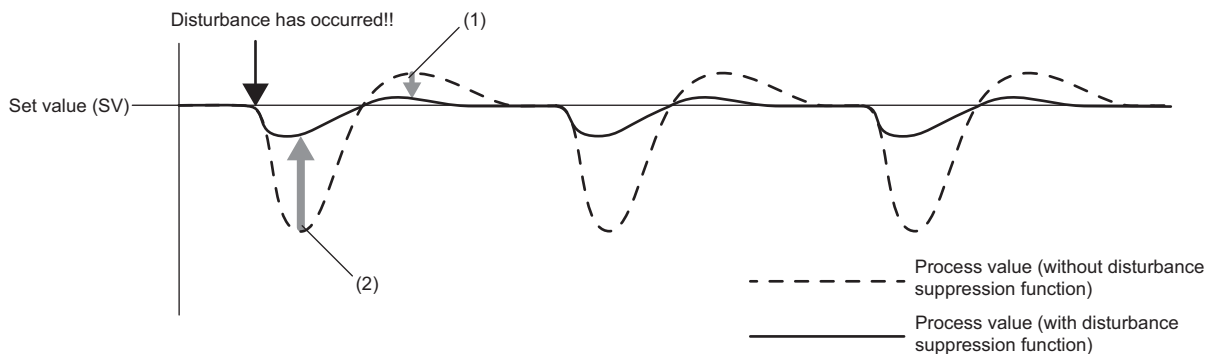

- (1) Overshoots after the bottom control are suppressed.
- (2) The temperature fall (bottom) is suppressed.

Precautions

This function uses a noise filter to avoid a false detection for the disturbance judgment. Thus, if the temperature fluctuation caused by disturbance is steep in terms of time, the disturbance judgment may delay.

Feed forward control

When an external factor that disturbs the control occurs, this control executes a corrective action to eliminate the effect to temperatures in advance.

The temperature fall (bottom) caused by the disturbance is suppressed by adding the feed forward value to an output.

The adjustment of the feed forward value can be selected from manually and automatically in 'CH1 Feed forward value tuning selection' (Un\G561).

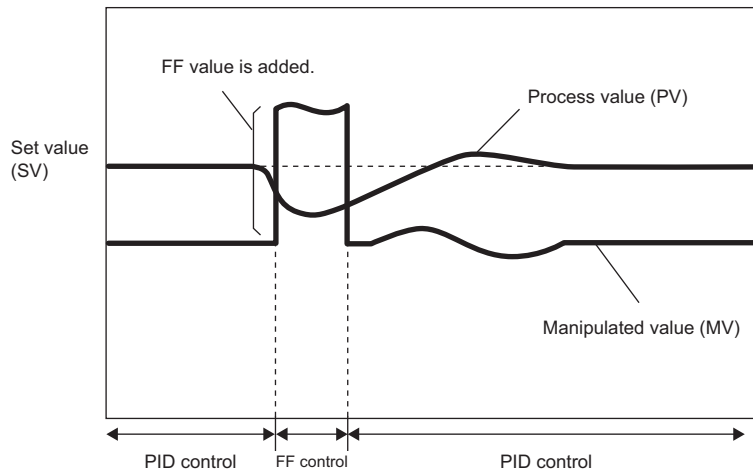

PID control after the bottom control

After the bottom has been suppressed by the feed forward control, the control is shifted to the PID control.

In this case, overshoots may occur. Thus, the overshoot value and the recovery time need to be adjusted for the recovery operation to the set value (SV).

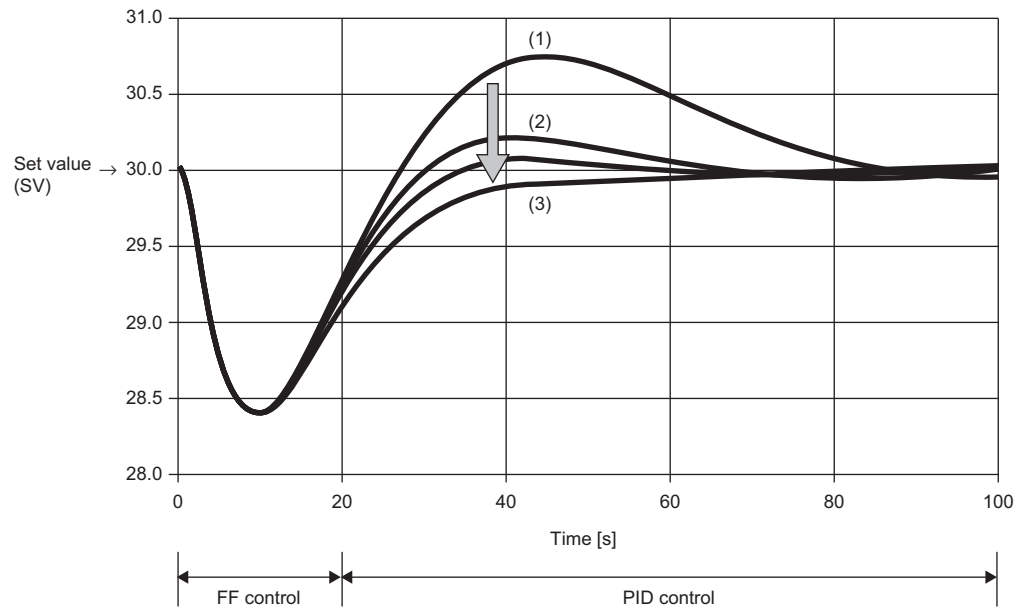

Select the set value (SV) restoration adjustment level from 0 to 10 and adjust the overshoot value and the recovery time.



- (1) PID control (no return adjustment)
- (2) Return adjustment value: Small
- (3) Return adjustment value: Large

Parameters and buffer memory addresses

The following shows the parameters and buffer memory addresses to be set in the disturbance suppression function.

- "Disturbance judging position" of "Disturbance suppression function" in "Application Setting"
- "Set value (SV) restitution adjustment" of "Disturbance suppression function" in "Application Setting"
- 'CH1 Feed forward value' (Un\G560) ( Page 291 CH1 Feed forward value)
- 'CH1 Feed forward value tuning selection' (Un\G561) ( Page 292 CH1 Feed forward value tuning selection)

Setting method



1. Set "Target Value(SV) Setting" of "Control basic parameters" in "Application Setting" and PID constants.

 [Navigation window] ⇒ [Parameter] ⇒ Target module ⇒ [Module Parameter] ⇒ [Application Setting] ⇒ [Control basic parameters]

For the setting calculation of PID constants, the auto tuning can be executed.

2. Set "Disturbance judging position" and "Set value (SV) restitution adjustment" of "Disturbance suppression function" in "Application Setting".

 [Navigation window] ⇒ [Parameter] ⇒ Target module ⇒ [Module Parameter] ⇒ [Application Setting] ⇒ [Disturbance suppression function]

- Set the deviation (Set value (SV) - Process value (PV)) for "Disturbance judging position". ( Page 288 CH1 Disturbance judgment position)
- Set a return action to be taken when the temperature process value (PV) returns to the set value (SV) from the temperature fall caused by disturbance for "Set value (SV) restitution adjustment". ( Page 290 CH1 Set value return adjustment)

3. Set 'CH1 Feed forward value tuning selection' (Un\G561) to Automatic-setting (1) and start the control. ( Page 292 CH1 Feed forward value tuning selection)

4. After the start of the control, the feed forward value is automatically calculated by giving a disturbance. During the automatic calculation, CH1 Feed forward value tuning status (Un\G416, b1) is on. ( Page 235 CH1 Feed forward value tuning flag)

5. CH1 Feed forward value change flag (Un\G416, b0) is turned on and the turning ends. ( Page 235 CH1 Feed forward value tuning flag)

After the completion of the turning, set 'CH1 Feed forward value tuning selection' (Un\G561) to No automatic-setting (0). ( Page 235 CH1 Feed forward value tuning flag)

Turning off and on 'Setting value backup command' (Y8) is not required because the calculated feed forward value is automatically backed up.

Point

When the tuning ends in failure, CH1 Feed forward value tuning error flag (Un\G416, b8) is turned on. ( Page 235 CH1 Feed forward value tuning flag)

Operating condition

When the following conditions are satisfied, the functions can be executed.

■Operating conditions for only the feed forward control

- CH1 Feed forward value tuning status (Un\G416, b1) is not on.
- The feed forward value is not 0.

■Operating condition for only the set value (SV) restoration adjustment

A value of 1 or larger has been set for the set value (SV) restoration adjustment.

■Operating conditions for the feed forward control and set value (SV) restoration adjustment

- The control is being executed.
- The AUTO mode is activated.
- The disturbance judgment position is not 0.
- The PID control has been set. (All of the proportional band (P), integral time (I), and derivative time (D) are not 0.)
- The set value (SV) has not been changed (Even when the setting variation rate limiter has been set, the set value (SV) has not been changed according to the variation rate).
- The temperature is not out of the temperature measuring range.
- The self-tuning is not being executed.
- The output variation limiter is 0.
- The simultaneous temperature rise is not being executed.
- The overshoot suppression function is not operating.

Startup conditions

The following control or function is started when the operating conditions have been satisfied and the following startup conditions are satisfied.

■Startup conditions of the feed forward control

- With 'CH1 Feed forward control READY flag' (Un\G417) on, the deviation exceeds the disturbance judgment position.
- With 'CH1 Feed forward control forced start READY flag' (Un\G418) on, 'CH1 Feed forward control forced starting signal' (Un\G559) is set to Feed forward control forced start (1).

■Startup condition of the set value (SV) restoration adjustment

The deviation (E) exceeds the disturbance judgment position.

Normal completion conditions

When the following conditions are satisfied, the following control or function is completed successfully and the control shifts to the PID control.

Normal completion conditions of the feed forward control

- A bottom has been detected
- The integral time has passed under the condition in which no disturbance has been detected at the disturbance judgment position.

Normal completion condition of the set value (SV) restoration adjustment

- The deviation (E) at the start of the disturbance suppression is 1% or lower of the maximum deviation, or the temperature process value (PV) has reached the set value (SV).
- The deviation (E) is within the disturbance judgment position and the temperature process value (PV) is judged to be stable enough.

Stop conditions

When the operating conditions are not satisfied or one of the following conditions is satisfied, the operation is stopped.

Stop condition for only the feed forward control

- 'CH1 Feed forward control forced starting signal' (UnG559) has been set to Feed forward control forced start (1), the temperature process value (PV) responds in the reverse direction of the disturbance judgment position, and the value exceeds the disturbance judgment width.

Ex.

The disturbance judgment position is -5°C.

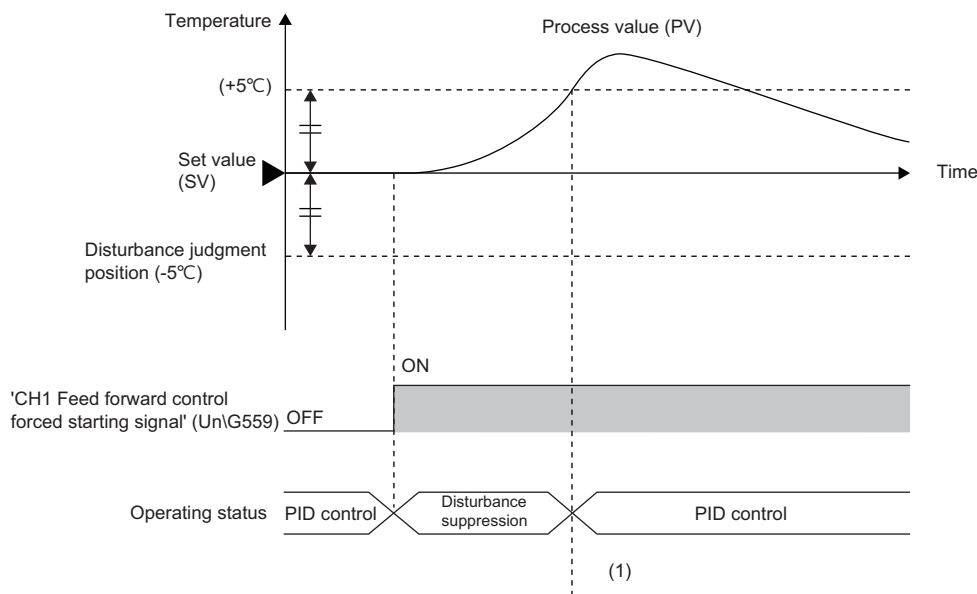

(1) Because the process value (PV) is larger than the reverse of the disturbance judgment position, the disturbance suppression is suspended and the control shifts to the PID control.

- When 'CH1 Feed forward control forced starting signal' (UnG559) has been set to Feed forward control forced start (1) and no disturbance has been detected at the disturbance judgment position, 'CH1 Feed forward control forced starting signal' (UnG559) is changed to Feed forward control forced start stop (0).

Point

When a disturbance has been detected at the disturbance judgment position, the operation does not stop even though 'CH1 Feed forward control forced starting signal' (UnG559) is changed to Feed forward control forced start stop (0).

Stop conditions for the set value (SV) restoration adjustment

The deviation (E) after a bottom exceeds the deviation (E) at the bottom.

■ Stop conditions for the feed forward control and set value (SV) restoration adjustment

- The proportional band (P) is changed.
- The integral time (I) is changed.
- The derivative time (D) is changed.
- The output limiter is changed.
- The overlap/dead band setting is changed in the heating-cooling control.
- The control response parameter is changed.
- The set value (SV) is changed.
- The sensor correction value and the primary delay digital filter setting are changed.
- The disturbance judgment position is changed.

The following figure shows the stop caused by the change of the integral time (I), derivative time (D), or the output limiter.

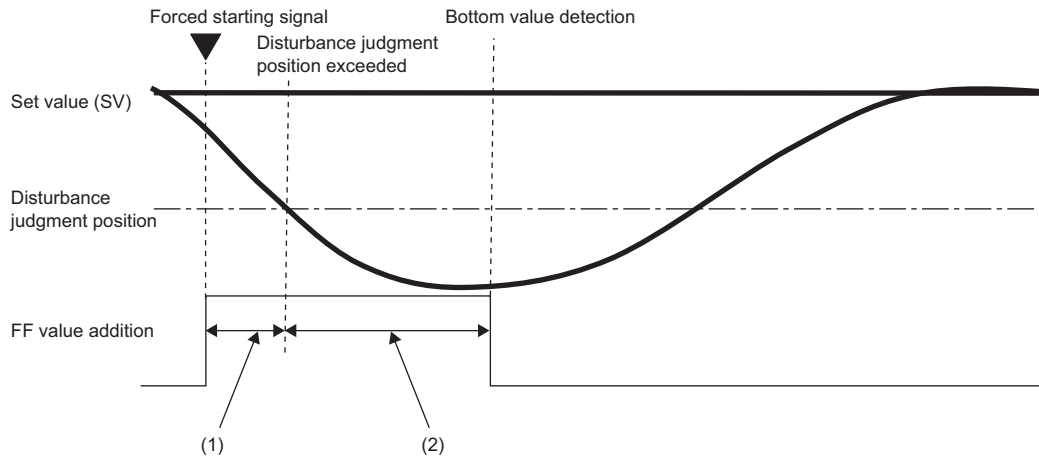

(1) Even though the following items are changed in this area, the operation does not stop. However, when the integral time (I) and derivative time (D) have been set to 0, the operation stops.

- Integral time (I)
- Derivative time (D)
- Output limiter

(2) When the following items are changed in this area, the operation stops.

- Integral time (I)
- Derivative time (D)
- Output limiter

Point

When a feed forward value has been applied by 'CH1 Feed forward control forced starting signal' (Un\G559), the operation does not stop even though the integral time (I), derivative time (D), and output limiter are changed.

1.36 Buffer Memory Data Backup Function

This function backs up data in buffer memory areas to the non-volatile memory.

The backed up data is transferred from the non-volatile memory to the buffer memory when the power is turned off and on or the CPU module is reset and the reset is canceled. Thus, temperatures can be controlled without writing data when the power is turned off and on or the CPU module is reset and the reset is canceled.

Target buffer memory areas

Refer to the list of buffer memory addresses. (☞ Page 161 List of buffer memory addresses)

Writing data to the non-volatile memory

This function can be used to back up the data that was directly written to the buffer memory areas using the PID constants set by the auto tuning function and the engineering tool. When the data is written to the non-volatile memory and the power is turned off and on or the CPU module is reset and the reset is canceled, the values in the buffer memory areas are not required to be set again.

Point

For the functions whose PID constants are automatically backed up after the auto tuning, refer to the following.

☞ Page 161 List of buffer memory addresses

To write data to the non-volatile memory, turn off and on 'Setting value backup command' (Y8).

When writing the data to the non-volatile memory is completed, 'Setting value backup completion flag' (X8) turns on.

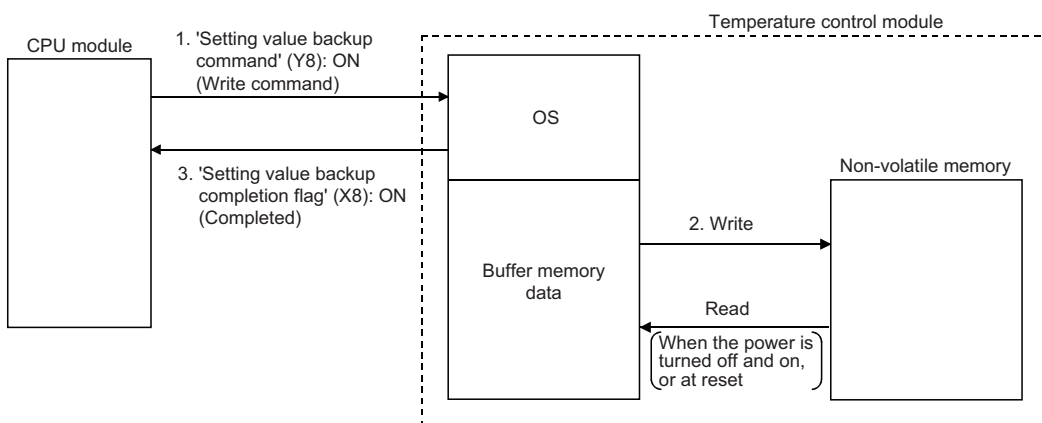

If writing the data to the non-volatile memory is not completed successfully, 'Setting value backup failure flag' (XA) turns on.

■Setting change

Change the settings of the buffer memory areas while 'Setting value backup completion flag' (X8) is off.

■Reading data from the non-volatile memory

Data can be read by the following methods.

- Turning off and on the power, or resetting the CPU module and canceling the reset
- Setting 'CH1 Memory's PID constants read command' (Un\G440) to Requested (1) (However, the data to be read is only the PID constants and the loop disconnection detection judgment time of the corresponding channels.)
- Setting 'CH1 Feed forward value memory read command' (Un\G441) to Requested (1) (However, the data to be read is only the feed forward values of the corresponding channels.)

■Precaution on after the execution of the set value backup function

After this function is executed in the Q compatible mode, the data transferred to the buffer memory areas when the power was turned off and on or the CPU module was reset and the reset was canceled is overwritten with new data by setting parameters with the engineering tool.

To use the set values stored as the backup data of the initial settings of the module, select one of the following actions.

- Do not configure the parameter setting of the engineering tool.
- When configuring the parameter setting of the engineering tool, correct the set values of the parameters to the ones stored as backup data, and write the parameters to the CPU module.

1.37 Overshoot Suppression Function

This function suppresses overshoots at the startup and the set value (SV) change.

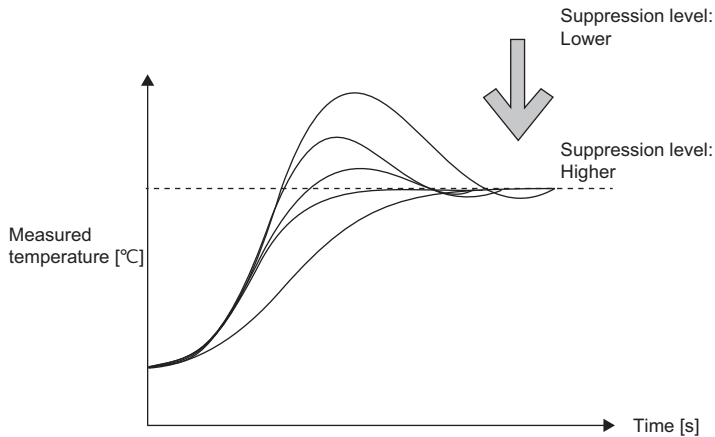

Setting "Fast" for "Control Response Parameters" of "Control basic parameters" in "Application Setting" with the overshoot suppression function enables the fast temperature rise.

Ex.

The following shows an example of temperature changes of when "Slow", "Normal", or "Fast" has been set for "Control Response Parameters" of "Control basic parameters" in "Application Setting".

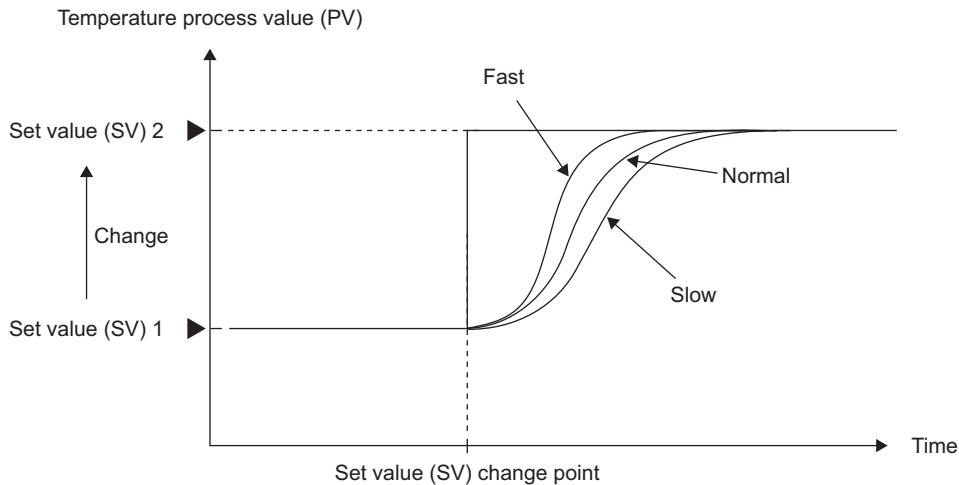

Operating conditions

When all of the following conditions are satisfied, the overshoot suppression function can be executed.

- The value set in "Overshoot control level setting" of "Overshoot control function" in "Application Setting" is 1 or more.
- The module is during control operation.
- The module is not during auto tuning operation.
- The proportional band (P) is not 0.
- The integral time (I) is not 0.
- The value is within the temperature measuring range.
- 'CH1 AUTO/MAN mode shift' (Un\G518) is AUTO (0).
- The module is not during self-tuning operation.
- The module is not using the simultaneous temperature rise function.
- The module is not using the setting variation rate limiter setting function.

Startup conditions

The overshoot suppression function is started when the deviation (E) becomes larger than 0.2% of the input span by performing any of the following operations.

- Changing the set value (SV)
- Changing the state of the module from control stop to control start
- Powering on the module

Completion conditions

When either of the following conditions is satisfied, the overshoot suppression function is completed and the control shifts to the PID control.

- The deviation (E) becomes equal to or smaller than 1% of the deviation (E) at the startup of the overshoot suppression function.
- The process value (PV) reaches the set value (SV).

Stop conditions

When any of the following conditions is satisfied, the overshoot suppression function is stopped and the control shifts to the PID control.

- An operating condition becomes unsatisfied.
- Temperature measurement lasts for 7200 seconds.
- The sensor correction value and the primary delay digital filter setting are changed.
- The overlap/dead band setting is changed.

Setting method

Configure the setting as follows.

 [Navigation window] ⇒ [Parameter] ⇒ Target module ⇒ [Module Parameter] ⇒ [Application Setting] ⇒ [Overshoot control function]

1.38 Error History Function

The errors or alarms that occurred in the temperature control module are stored in the buffer memory as history. Up to 16 errors and 16 alarms can be stored.

Operation

When errors occur, error codes and error times of the errors are stored in 'Error history No.1' (Un\G3600 to Un\G3609) in order.

When alarms occur, alarm codes and alarm times of the alarms are stored in 'Alarm history No.1' (Un\G3760 to Un\G3769) in order.

- Error code assignment

	b15	to	b8 b7	to	b0
Un\G3600	Error code				
Un\G3601	First two digits of the year		Last two digits of the year		
Un\G3602	Month		Day		
Un\G3603	Hour		Minute		
Un\G3604	Second		Day of the week		
Un\G3605	Millisecond (higher-order digits)		Millisecond (lower-order digits)		
Un\G3606	System area				
⋮					
⋮					
Un\G3609					

- Alarm code assignment

	b15	to	b8 b7	to	b0
Un\G3760	Alarm code				
Un\G3761	First two digits of the year		Last two digits of the year		
Un\G3762	Month		Day		
Un\G3763	Hour		Minute		
Un\G3764	Second		Day of the week		
Un\G3765	Millisecond (higher-order digits)		Millisecond (lower-order digits)		
Un\G3766	System area				
⋮					
⋮					
Un\G3769					

Ex.

Storage example of error history and alarm history data

Item	Stored contents	Storage example ^{*1}
First two digits of the year/last two digits of the year	Stored in BCD code.	2015H
Month/day		131H
Hour/minute		1234H
Second		56H
Day of the week	One of the following values is stored in BCD code. Sunday: 0, Monday: 1, Tuesday: 2, Wednesday: 3, Thursday: 4, Friday: 5, and Saturday: 6	6H
Millisecond (upper)	Stored in BCD code.	7H
Millisecond (lower)		89H

*1 Value stored when an error occurs at 12:34:56.789 on Saturday, January 31, 2015

The start address of the error history where the latest error has been stored can be checked in 'Latest address of error history' (Un\G2).

The start address of the alarm history where the latest alarm has been stored can be checked in 'Latest address of alarm history' (Un\G4).

Ex.

When the third error occurred

The third error is stored in Error history No.3 and 3620 (the start address of Error history No.3) is stored in 'Latest address of error history' (Un\G2).

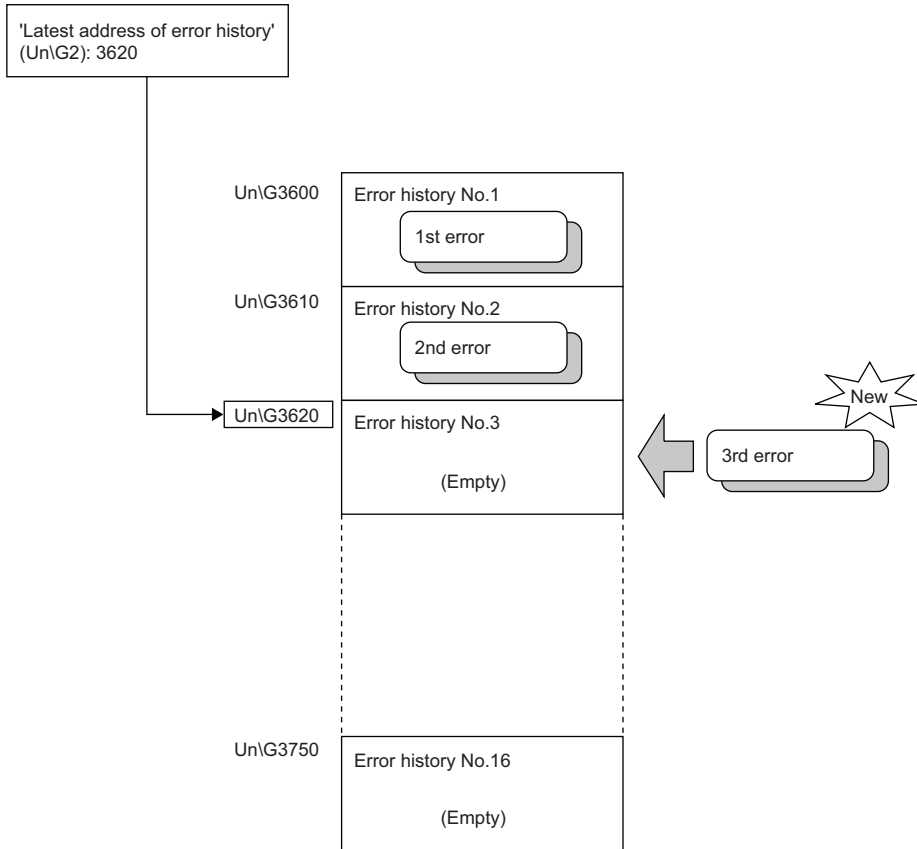

Ex.

When the 17th error occurred

The 17th error is stored in Error history No.1 and 3600 (the start address of Error history No.1) is stored in 'Latest address of error history' (Un\G2).

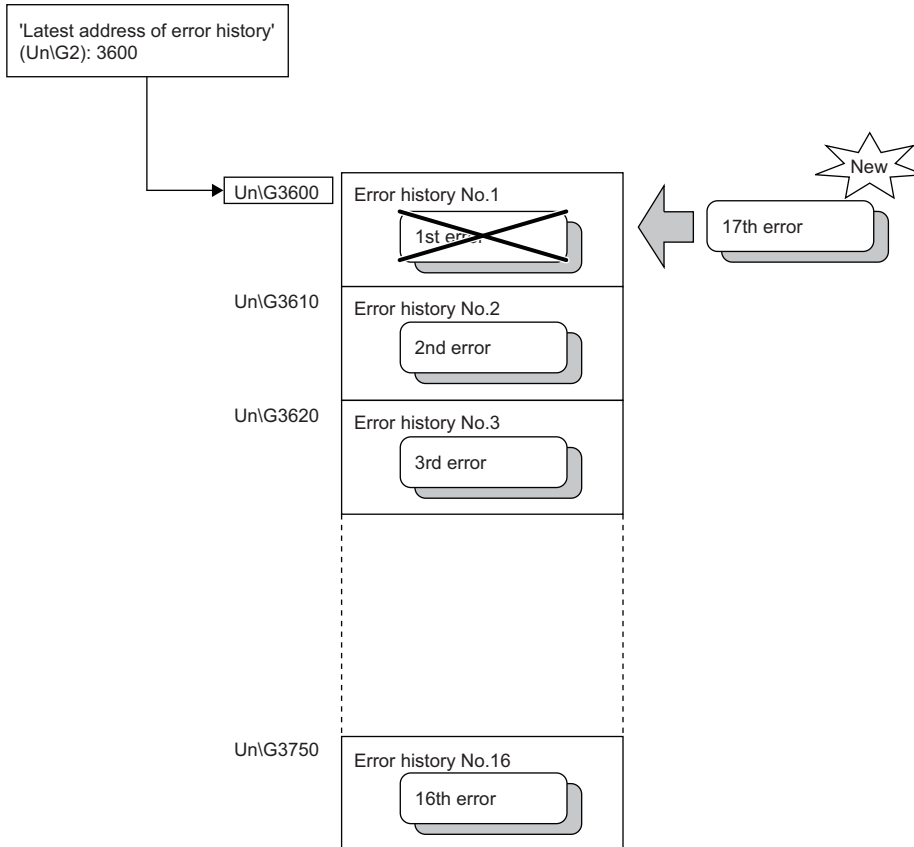
**Point**

- When the storage areas for the error history are full, data in 'Error history No.1' (Un\G3600 to Un\G3609) is overwritten in order and recording of error history continues. The history data before the data overwriting is deleted.
- The same processing is executed to the alarm history.
- The registered error history is cleared by powering off of the temperature control module or resetting the CPU module.

1.39 Event History Function

The errors or alarms occurred and operations executed on the temperature control module are collected as event information into the CPU module.

The CPU module collects the information of the event that occurred in the temperature control module and stores the information in the data memory in the CPU module or an SD memory card.

The event information collected by the CPU module can be displayed on the engineering tool and the occurrence history can be checked in chronological order.

Event type	Classification	Description
System	Error	A self-diagnostics error detected in each module
	Warning	An alarm detected in each module
	Information	A normal detection of the information that is not to be classified as an error or alarm, or an operation that the system automatically executes
Security	Warning	An operation judged as unauthorized access to each module
	Information	An operation that cannot be judged as unauthorized access or success of unlocking a password
Operation	Warning	A deletion operation (data clear operation) that was executed to each module and not judged as a self-diagnostics error. This operation may possibly be changed.
	Information	An operation that was executed by users and may change the system behavior such as module initialization or configuration

Setting method

Set the event history function in the Event History Setting window of the engineering tool. For the setting method, refer to the following.

 MELSEC iQ-R CPU Module User's Manual (Application)

Displaying the event history

Display the event history from the menu of the engineering tool. For details on the operating procedure and how to check the contents, refer to the following.

 GX Works3 Operating Manual

Event history list

The following table lists the events that occurs in the temperature control module when the event type is Operation.

Event code	Event classification	Event name	Description	Added information
20010	Information	Module initialization	Initialization of the module has been executed.	—
20011	Information	Backing up the module	The module has been backed up.	—
20041 to 20044	Information	Auto tuning	The auto tuning has been executed.	—
20051 to 20054	Information	PID forced stop	The PID forced stop has been executed.	—
20030	Information	Online module change	The online module change has been executed.	—
20100	Information	Error clear	An error clear request has been issued.	—

1.40 Interrupt Function

This function starts an interrupt program of the CPU module when an interrupt factor such as an error, alarm, or a shutoff of the external power supply is detected.

Up to 16 interrupt pointers per module can be used in the temperature control module.

Operation

■Detection of interrupt factors

When an interrupt factor occurs, an interrupt request is sent to the CPU module at the same time as 'Interrupt factor detection flag [n]' (Un\G5 to Un\G20) is turned to Interrupt factor (1).

■Resetting an interrupt factor

When 'Interrupt factor reset request [n]' (Un\G156 to Un\G171) corresponding to a generated interrupt factor is set to Reset request (1), the specified interrupt factor is reset and 'Interrupt factor detection flag [n]' (Un\G5 to Un\G20) is set to No interrupt factor (0).

Setting method

To use the interrupt function, set "Condition target", "Channel specification target", "Interrupt factor transaction setting", and "Interrupt pointer" with the engineering tool. After configuring the settings, write the project and enable the settings.

 [Navigation window] ⇒ [Parameter] ⇒ Target module ⇒ [Module Parameter] ⇒ [Interrupt setting]

The following table lists the items in the Interrupt setting window.

Item	Description
Condition target setting	Select a target factor to detect interrupts.
Condition target channel setting	When the condition target to detect interrupts has been set to channels, select a target channel.
Interrupt factor generation setting	Configure the interrupt request setting for when an interrupt factor occurs while the same interrupt factor has been detected.
Interrupt pointer	Specify an interrupt pointer number to start when an interrupt factor is detected.

■Condition target setting

Select a condition target factor to detect interrupts.

For details on the detection factors, refer to the following.

 Page 216 Condition target setting [n]

■Condition target channel setting

When the condition target to detect interrupts has been set to channels, select a target channel.

For details on the setting, refer to the following.

 Page 217 Condition target channel setting [n]

■Interrupt factor generation setting



Configure the interrupt request setting for when an interrupt factor occurs while the same interrupt factor has been detected.

- When Interrupt reissue request has been set and an interrupt factor occurs while the same interrupt factor has been detected, an interrupt request is sent to the CPU module again.
- When No interrupt reissue request has been set and an interrupt factor occurs while the same interrupt factor has been detected, no interrupt request is sent to the CPU module.

■Interrupt pointer

Specify an interrupt pointer number to start when an interrupt factor is detected. For details on interrupt pointers, refer to the following.

 MELSEC iQ-R CPU Module User's Manual (Application)

-
- When 'Condition target setting [n]' (Un\G232 to Un\G247) has been set to Disable (0), no interrupt request is sent to the CPU module.
 - To reset an interrupt factor, set 'Interrupt factor reset request [n]' (Un\G156 to Un\G171) to Reset request (1) until 'Interrupt factor detection flag [n]' (Un\G5 to Un\G20) changes to No interrupt factor (0).
 - Interrupt factors are reset only when 'Interrupt factor reset request [n]' (Un\G156 to Un\G171) changes from No reset request (0) to Reset request (1).
 - The same setting of 'Condition target setting [n]' (Un\G232 to Un\G247) can be set to multiple interrupt pointers. When an interrupt of 'Condition target setting [n]' (Un\G232 to Un\G247) that has been set to multiple interrupt pointers occurs, interrupt programs are executed following the priority of the interrupt pointers. For the priority of interrupt pointers, refer to the following.
 MELSEC iQ-R CPU Module User's Manual (Application)
 - When 'Condition target channel setting [n]' (Un\G264 to Un\G279) has been set to All channels (0), an interrupt detection target has been set to each channel of 'Condition target setting [n]' (Un\G232 to Un\G247), and alerts occur in multiple channels, interrupt requests that have the same factor will be sent to the CPU module for several times. At this time, the CPU module executes multiple interrupt programs simultaneously, the scan monitoring function of the CPU module judges the programs cannot be completed successfully, and a CPU error may occur. When a CPU error occurs, refer to the following.
 MELSEC iQ-R CPU Module User's Manual (Application)
-

Setting example

Ex.

When an interrupt program (I50) is executed in CH1 at the occurrence of a loop disconnection

- Parameter setting

Set "Interrupt setting" of the parameter as follows.

No.	Condition target setting	Condition target channel setting	Interrupt pointer
4	Alert definition (Loop disconnection)	CH1	I50

- Label setting

Classification	Label name	Description	Device										
Module label	RCPU.stSM.bAlways_ON	Always ON	SM400										
	RCPU.stSM.bAfter_RUN1_Scan_ON	One scan ON after RUN	SM402										
	R60TC_1.stInterruptSettingData2_D.unInterruptFactorMask_D[3].0	Interrupt factor mask	U0\G127.0										
	R60TC_1.stInterruptSettingData2_D.unInterruptFactorResetRequest_D[3].0	Interrupt factor reset request	U0\G159.0										
Label to be defined	Define global labels as follows.												
	<table border="1"> <thead> <tr> <th></th> <th>Label Name</th> <th>Data Type</th> <th>Class</th> <th>Assign (Device/Label)</th> </tr> </thead> <tbody> <tr> <td>1</td> <td>G_bDisconnectDetection</td> <td>Bit</td> <td>VAR_GLOBAL</td> <td>F0</td> </tr> </tbody> </table>				Label Name	Data Type	Class	Assign (Device/Label)	1	G_bDisconnectDetection	Bit	VAR_GLOBAL	F0
	Label Name	Data Type	Class	Assign (Device/Label)									
1	G_bDisconnectDetection	Bit	VAR_GLOBAL	F0									

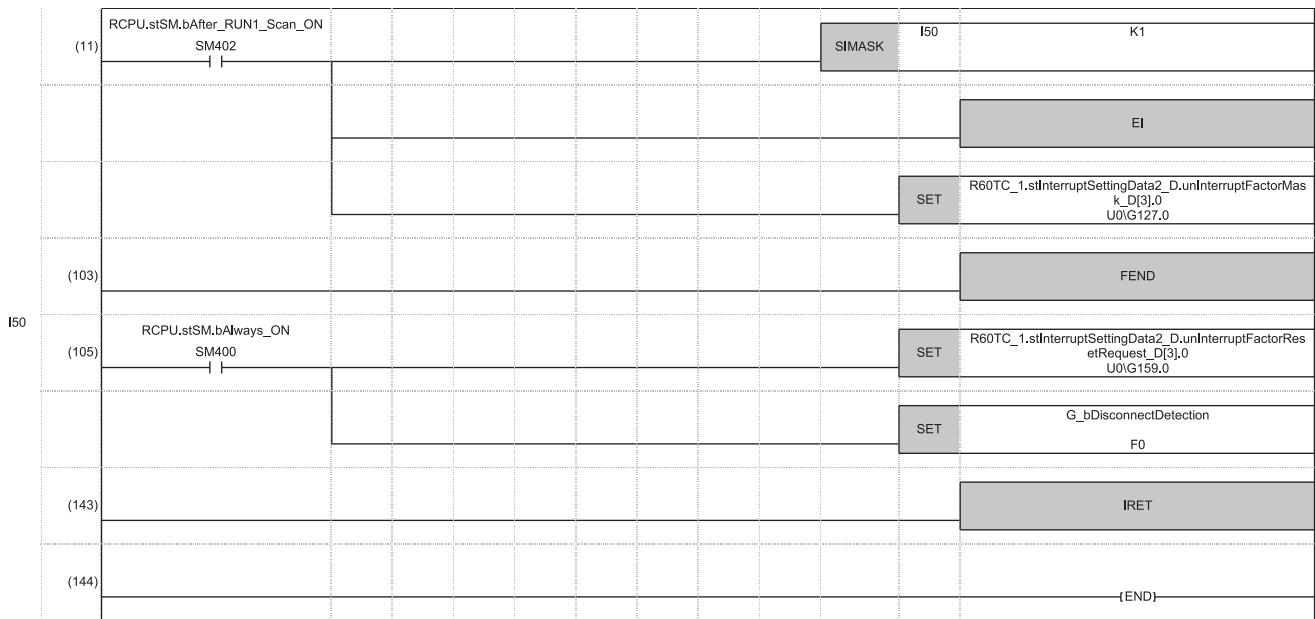

1.41 Q Compatible Mode Function

This function arranges the buffer memory addresses of the temperature control module to become equivalent to the ones of a MELSEC-Q series module.

Sequence programs proven with the MELSEC-Q series module can be used.

The following table shows the MELSEC iQ-R series temperature control modules that can be replaced with the MELSEC-Q series temperature control modules.

MELSEC iQ-R series temperature control module	MELSEC-Q series temperature control module
R60TCTRT2TT2	• Q64TCTTN • Q64TCTT
R60TCTRT2TT2BW	• Q64TCTTBWN • Q64TCTTBW
R60TCRT4	• Q64TCRTN • Q64TCRT
R60TCRT4BW	• Q64TCRTBWN • Q64TCRTBW

Operation

In the Q compatible mode, only the assignment of buffer memory areas is changed.

The assignment of I/O signals is the same as the one for the R mode. Every function added for the MELSEC iQ-R series has been assigned to each buffer memory area, and all the added functions can be used in the Q compatible mode. Thus, not major program revision is required when a program for the MELSEC-Q series is used.

In addition, PID constants can be set with parameters.

Point

- When a program for the MELSEC-Q series has been used and an error code has been set as an operating condition or interlock condition, the program does not properly operate.
- In the Q compatible mode, a program that uses FBs and labels cannot be created. When using FBs and labels, create a program in the R mode.

Setting method

1. When adding a new module, select a module whose name has "(Q)" after its module model name.

 [Navigation window] ⇒ [Parameter] ⇒ [Module Information] ⇒ Right-click ⇒ [Add New Module]

2. Set parameters in the same way as in the R mode.

3. Write the parameters to the CPU module and restart the module.

Restriction

While the module is running, the mode cannot be shifted between the R mode and Q compatible mode.

2 PARAMETER SETTING

Set the parameters of each channel.

Setting parameters eliminates the need of a program for setting parameters.

2

2.1 Basic Setting

Setting method

Configure the settings in "Base Setting" of the engineering tool.

1. Start parameters.

[Navigation window] ⇒ [Parameter] ⇒ [Module Information] ⇒ Target module ⇒ [Module Parameter] ⇒ [Base Setting]

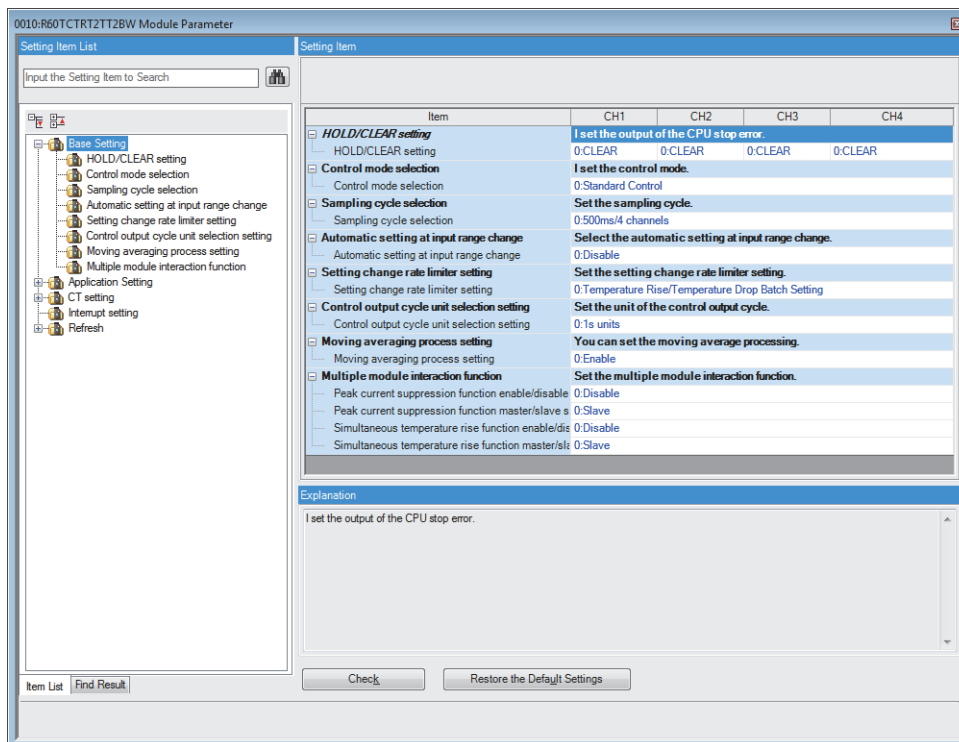

2. Double-click the item to change the setting, and enter a setting value.

- Items where a value is selected from a drop-down list

Clicking the [▼] button of the item to be set displays the drop-down list. Select the item.

- Items where a value is entered into a text box

Double-click the item to be set, and enter a value.

2.2 Application Setting

Setting method

Configure the settings in "Application Setting" of the engineering tool.

1. Start parameters.

[Navigation window] ⇒ [Parameter] ⇒ [Module Information] ⇒ Target module ⇒ [Module Parameter] ⇒ [Application Setting]

- In the R mode

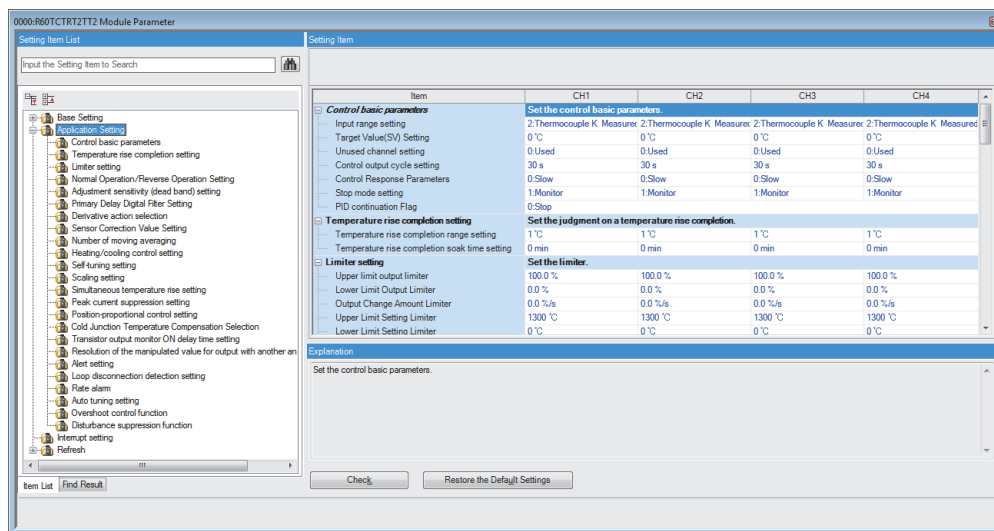

- In the Q compatible mode

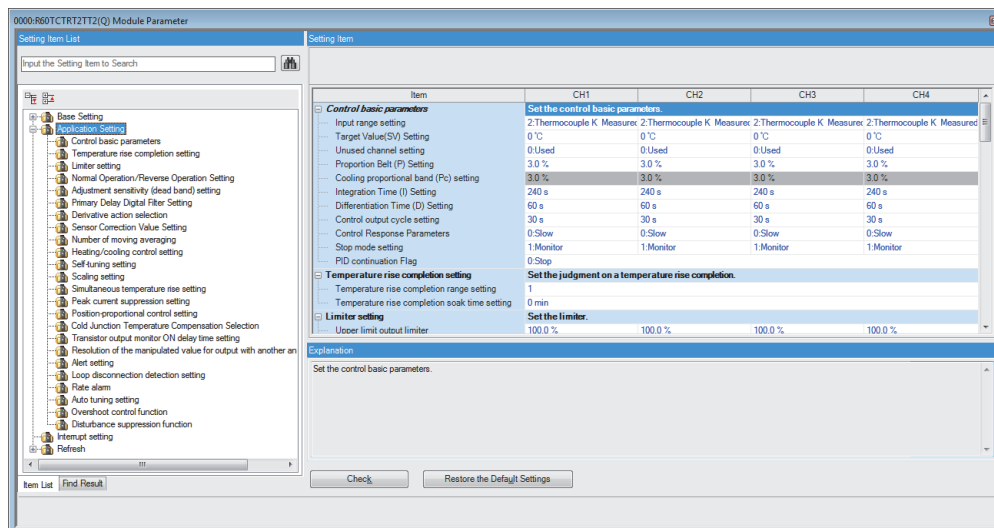

2. Double-click the item to change the setting, and enter a setting value.

- Items where a value is selected from a drop-down list

Clicking the [▼] button of the item to be set displays the drop-down list. Select the item.

- Items where a value is entered into a text box

Double-click the item to be set, and enter a value.

2.3 CT Setting

Setting method

Configure the settings in "CT setting" of the engineering tool.

1. Start parameters.

[Navigation window] ⇒ [Parameter] ⇒ [Module Information] ⇒ Target module ⇒ [Module Parameter] ⇒ [CT setting]

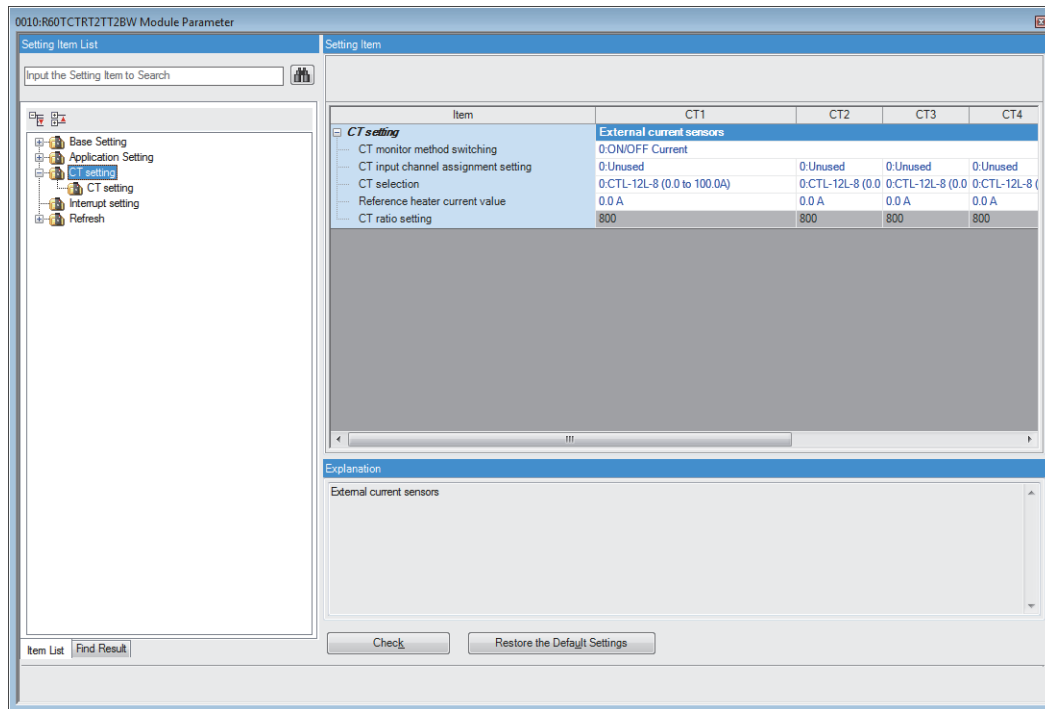

2. Double-click the item to change the setting, and enter a setting value.

- Items where a value is selected from a drop-down list

Clicking the [▼] button of the item to be set displays the drop-down list. Select the item.

- Items where a value is entered into a text box

Double-click the item to be set, and enter a value.

2.4 Interrupt Setting

Setting method

Configure the settings in "Interrupt setting" of the engineering tool.

1. Start parameters.

[Navigation window] ⇒ [Parameter] ⇒ [Module Information] ⇒ Target module ⇒ [Module Parameter] ⇒ [Interrupt setting]

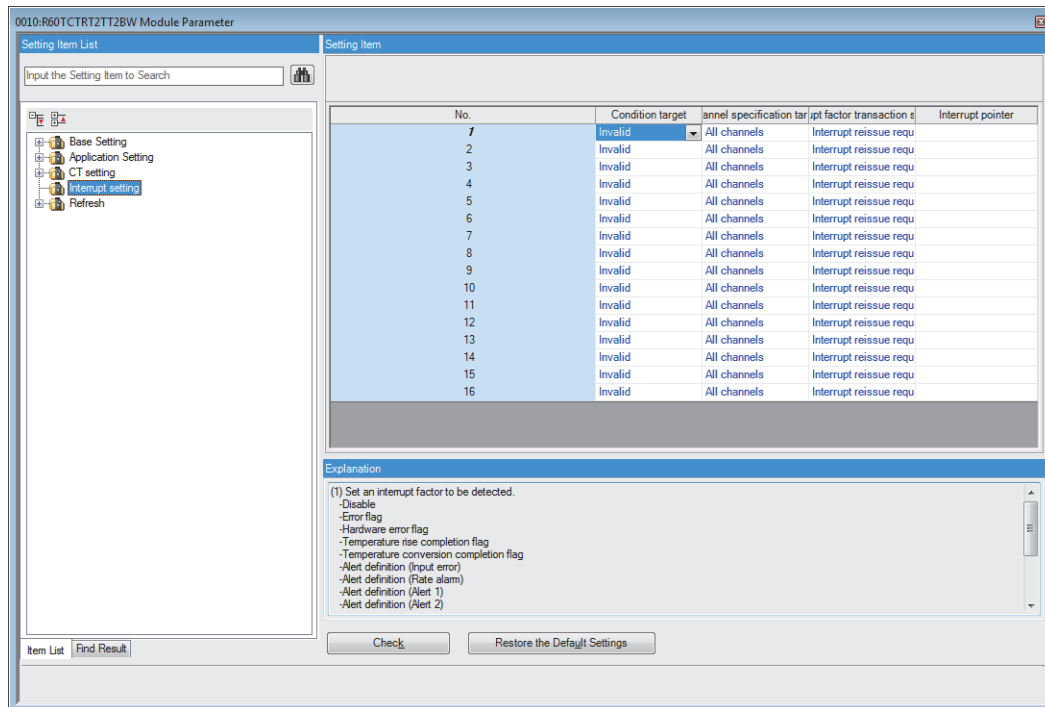

2. Double-click the item to change the setting, and enter a setting value.

- Items where a value is selected from a drop-down list

Clicking the [▼] button of the item to be set displays the drop-down list. Select the item.

- Items where a value is entered into a text box

Double-click the item to be set, and enter a value.

2.5 Refresh Settings

Setting method

Set the buffer memory areas of the temperature control module to be automatically refreshed.
Configuring the refresh settings eliminates the need of a program for reading/writing data.

1. Start parameters.

[Navigation window] ⇒ [Parameter] ⇒ [Module Information] ⇒ Target module ⇒ [Module Parameter] ⇒ [Refresh]

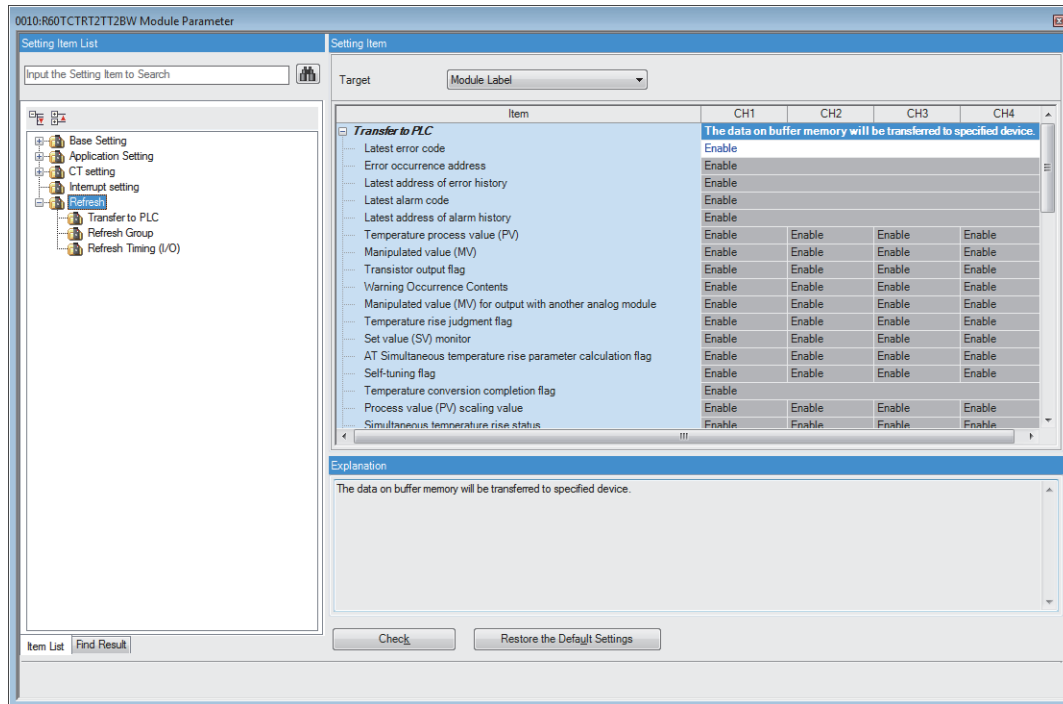

2. Click "Target" and set a refresh destination.

- When "Target" is "Module Label"

Set whether to enable or disable the auto refresh by setting "Latest error code" to "Enable" or "Disable".

- When "Target" is "Refresh Data Register (RD)"

The transfer destinations of all items are automatically set by setting a start device name for "Top Device Name".

- When "Target" is "Device"

Double-click the item to be set, and enter a value.

3. Click "Refresh Group" and set the timing to execute the auto refresh.

Set "Refresh Group" to "At the Execution Time of END Instruction" or "At the Execution Time of Specified Program".

When setting "At the Execution Time of Specified Program", double-click "Group [n](n: 1 to 64)" and set a value of 1 to 64.

Refresh processing time

The refresh processing time [μs] is included in the scan time of the CPU module. For the scan time, refer to the following.

 MELSEC iQ-R CPU Module User's Manual (Application)

The refresh processing time [μs] for refresh settings is as follows.

- Refresh processing time [μs] = Refresh read (transfer to the CPU) time

The refresh read time varies depending on the refresh destination selected in "Target".

When "Target" is a module label or a refresh data register (RD)

The following table lists the refresh read time of when the RnCPU is used.

Model	With refresh settings
R60TCRT2TT2, R60TCRT4	24.64 μs
R60TCRT2TT2BW, R60TCRT4BW	26.02 μs
R60TCRT2TT2 (Q compatible mode), R60TCRT4 (Q compatible mode)	50.12 μs
R60TCRT2TT2BW (Q compatible mode), R60TCRT4BW (Q compatible mode)	51.50 μs

When "Target" is "Device"

The refresh read time is calculated from the number of items with refresh settings and their number of transfers (words). For the calculation method, refer to the following.

 MELSEC iQ-R CPU Module User's Manual (Application)

For calculation, replace the items in a calculation formula with the following items in Description.

Item	Description
Number of items with refresh settings	Number of devices in use
Refresh time for 1st to nth setting items (A)	0.05 μs per word*1

*1 The value is the time of when the R□CPU is used.

Ex.

For the R60TCRT2TT2, read refresh settings are configured in all of 104 items (104 words in total).

$$104 \times 0.98 + 0.05 \times 104 + 11.6 = 118.72\mu\text{s}$$

Hence, the refresh read time is 118.72 μs .

3 TROUBLESHOOTING

This chapter describes errors that may occur when the temperature control module is used and troubleshooting.

3.1 Checks Using LEDs

Checking the display status of LEDs is the primary diagnostics without an engineering tool, narrowing down the causes of the error that has occurred.

A state of the temperature control module can be checked with the RUN LED, ERR LED, ALM LED, and HBA LED. The following table shows the correspondence between each LED status and each state of the temperature control module.

Name	Description
RUN LED	Indicates the operating status of the temperature control module. On: The module is operating normally. Flashing: The module is selected as a module for the online module change. Off: 5V power supply has been shut off, a watchdog timer error has occurred, or replacing the module is allowed in the process of the online module change.
ERR LED	Indicates the error status of the temperature control module.*1 On: An error has occurred. Off: Normal operation
ALM LED	Indicates the alert status of the temperature control module. On: An alert has occurred. Flashing: A temperature process value (PV) is out of the temperature measuring range, a loop disconnection has been detected, or a temperature sensor has not been connected. Off: No alert has occurred.
HBA LED	Indicates the heater disconnection detection status or the output off-time current error status of the R60TCRT2TT2BW and R60TCRT4BW. On: A heater disconnection or an output off-time current error has been detected. Off: No heater disconnection or output off-time current error has occurred.

*1 For details, refer to the following.
 Page 142 List of Error Codes

When the RUN LED flashes or turns off

When the RUN LED flashes or turns off, check the following items.

Check item	Corrective action
Is the power supplied?	Check that the supply voltage of the power supply module is within the rated range.
Is the capacity of the power supply module enough?	Calculate the current consumption of the installed CPU module, I/O module, and intelligent function module to check whether the power capacity is sufficient.
Has a watchdog timer error occurred?	<ul style="list-style-type: none"> Reset the CPU module or turn on the power supply again. Replace the temperature control module.
Is replacing the module allowed in the process of the online module change?	Perform the online module change. For details, refer to the following.  MELSEC iQ-R Online Module Change Manual

When the ERR LED turns on

When the ERR LED turns on, check the following items.

Check item	Corrective action
Has an error occurred?	Check 'Latest error code' (UnlG0), and take a corrective action described in List of Error Codes.  Page 142 List of Error Codes
Is the cold junction temperature compensation resistor disconnected or loose? (for the R60TCRT2TT2 and the R60TCRT2TT2BW only)	Properly connect the cold junction temperature compensation resistor.

When the ALM LED turns on or flashes

When the ALM LED turns on or flashes, check the following items.

When the ALM LED turns on

Check item	Corrective action
Has CH□ Alert flag turned on?	Check CH□ Alert definition and take the appropriate corrective action. (☞ Page 224 CH1 Alert definition)

When the ALM LED flashes

Check item	Corrective action
Has the temperature process value (PV) exceeded the temperature measuring range set as the input range?	Change the setting value of CH□ Input range to a value within the temperature measuring range to be used. (☞ Page 247 CH1 Input range)
Is there a channel where no temperature sensor has been connected?	Set the channel where no temperature sensor has been connected to Unused in "Unused channel setting" of "Application Setting". (☞ Page 251 CH1 Unused channel setting)
Has a loop disconnection been detected?	Check for a load disconnection, externally-operable device failure, and sensor disconnection.

When the HBA LED turns on

When the HBA LED turns on, check the following items.

Check item	Corrective action
Has a heater disconnection been detected? (Has b12 of CH□ Alert definition turned on?)	<ul style="list-style-type: none">• Check the heater has been powered on.• Check for a load disconnection and externally-operable device failure.
Has an output off-time current error been detected? (Has b14 of CH□ Alert definition turned on?)	Check for a load disconnection and externally-operable device failure.

3.2 Checking the Module Status

An error code of the temperature control module can be checked in the "Module Diagnostics" window of the engineering tool.

[Diagnostics] ⇒ [System Monitor] ⇒ Right click on the module to be checked. ⇒ "Module Diagnostics"

The screenshot shows the 'Module Diagnostics' window for module R60TCTRT2TT2. The 'Error Information' tab is active, displaying a table with one error entry:

No.	Occurrence Date	Status	Error Code	Overview
1	2015/07/02 18:52:58.410		3001	Hardware error

Below the table, a legend indicates: Major, Moderate, Minor. The 'Detailed Information' section shows:

- Cause:** A hardware failure has occurred in the module.
- Corrective Action:** Check whether the terminal block or the cold junction temperature compensation resistor is not disconnected. Cycle the power supply. If the error occurs again, the possible cause is a failure of the module. Please consult your local Mitsubishi system service, service center, or representative, explaining a detailed description of the problem.

An alarm code, error history, and alarm history can be checked in the "Event History" window of the engineering tool.

[Diagnostics] ⇒ [System Monitor] ⇒ [Event History] button

The screenshot shows the 'Event History' window for CPU (PLC No. 1) Start I/O No. 3E00. It displays a list of events with the following columns: No., Occurrence Date, Event Type, Status, Event Code, and Overview.

No.	Occurrence Date	Event Type	Status	Event Code	Overview
00002	2015/07/02 18:52:58.410	System		03001	Hardware error
00003	2015/07/02 18:52:43.822	Operation		24101	Operating status change (STOP)
00004	2015/07/02 18:52:39.910	System		00804	CH4 Process value (PV) out of input
00005	2015/07/02 18:52:39.910	System		00803	CH3 Process value (PV) out of input
00006	2015/07/02 18:52:39.910	System		00802	CH2 Process value (PV) out of input
00007	2015/07/02 18:52:39.910	System		00801	CH1 Process value (PV) out of input
00008	2015/07/02 18:52:39.472	Operation		24100	Operating status change (RUN)

The legend indicates: Major, Moderate, Minor, Warning, Information. The 'Detailed Information' section shows:

- System configuration information:** I/O No. :0000, Slot No. :0, Base No. :0(Main base)
- Cause:** - A moderate error has been notified from the intelligent function module connected.
- Corrective Action:** - Check the detailed information (system configuration information), identify the error module, and eliminate the error cause.

3.3 Troubleshooting by Symptom

When 'Module READY flag' (X0) does not turn on

When 'Module READY flag' (X0) does not turn on, check the following items.

Check item	Corrective action
Has a watchdog timer error occurred?	<ul style="list-style-type: none"> Reset the CPU module or turn on the power supply again. Replace the temperature control module.
Has an error occurred in the CPU module?	Refer to the MELSEC iQ-R CPU Module User's Manual (Application).

When 'Error flag' (X2) is on

When 'Error flag' (X2) is on, check the following items.

Check item	Corrective action
Has an error occurred?	Check Latest error code, and take a corrective action described in List of Error Codes. (Page 142 List of Error Codes)

When 'Hardware error flag' (X3) is on

When 'Hardware error flag' (X3) is on, check the following items.

Check item	Corrective action
Is the cold junction temperature compensation resistor disconnected or loose? (for the R60TCTRT2TT2 and the R60TCTRT2TT2BW only)	Properly connect the cold junction temperature compensation resistor.
Other than above	A hardware failure has occurred in the temperature control module. Please consult your local Mitsubishi representative.

When the auto tuning does not start

When the auto tuning does not start (CH□ Auto tuning status (X4 to X7) does not turn on), check the following items.

Check item	Corrective action
Have the auto tuning start conditions been met?	Refer to Auto Tuning Function and check whether all the conditions have been met. (Page 35 Auto Tuning Function)
Has the auto tuning ended abnormally?	Refer to Conditions where auto tuning ends abnormally and check whether the auto tuning has ended abnormally. If it has ended abnormally, remove the cause. Then execute auto tuning again. (Page 35 Auto Tuning Function)

When the auto tuning is not completed

When the auto tuning is not completed (CH□ Auto tuning status (X4 to X7) remains on and does not turn off), check the following items.

Check item	Corrective action
Is Memory's PID constants write completion flag on?	Set CH□ Automatic backup setting after auto tuning of PID constants to Disable (0) and turn off Memory's PID constants write completion flag.
Has CH□ Memory's PID constants read command been set to Requested (1)?	Set CH□ Memory's PID constants read command to Not requested (0).
Has a correct set value (SV) been set? (Is the manipulated value (MV) still 0% because the set value (SV) is small?)	Set the set value (SV) to the desired value.

When the self-tuning does not start

When the self-tuning does not start (CH□ Auto tuning status (X4 to X7) does not turn on), check the following items.

Check item	Corrective action
Have the self-tuning start conditions been met?	Refer to Self-tuning Function and check whether all the conditions have been met. (☞ Page 44 Self-tuning Function)
Has the self-tuning ended abnormally?	Refer to Conditions where self-tuning ends abnormally and check whether the auto tuning has ended abnormally. If it has ended abnormally, remove the cause. If the buffer memory setting was changed during self-tuning, restore the value to the one prior to change. (☞ Page 44 Self-tuning Function)

When 'Setting value backup failure flag' (XA) is on

When 'Setting value backup failure flag' (XA) is on, check the following items.

Check item	Corrective action
Has backing up data to the non-volatile memory failed?	Turn off and on 'Setting value backup command' (Y8) and write data to the non-volatile memory. When writing data fails again, a hardware failure has occurred. Please consult your local Mitsubishi representative.
Has reading data from the non-volatile memory failed?	

When 'CH□ Alert flag' (XC to XF) is on

When CH□ Alert flag (XC to XF) is on, check the following items.

Check item	Corrective action
Has the temperature process value (PV) exceeded the alert set value range?	<ul style="list-style-type: none"> • Check CH□ Alert definition and take the appropriate corrective action. (☞ Page 224 CH1 Alert definition) • Check and change the alert set value. (☞ Page 241 CH1 Alert set value 1)
Has a disconnection been detected?	Check CH□ Alert definition and take the appropriate corrective action. (☞ Page 224 CH1 Alert definition)

When the temperature process value (PV) is abnormal

When the temperature process value (PV) is abnormal, check the following items.

Check item	Corrective action
Is the thermocouple wiring resistance value too high?	<ul style="list-style-type: none"> • Check the thermocouple wiring resistance value and check whether a difference in the temperatures was caused by the wiring resistance. (☞ MELSEC iQ-R Temperature Control Module User's Manual (Startup)) • Use the sensor correction function to correct the difference in the temperatures caused by the wiring resistance. (☞ Page 56 Sensor Correction Function)

3.4 List of Error Codes

If an error occurs in operation of the temperature control module, the error code of the error is stored into 'Latest error code' (Un\G0) of the buffer memory and 'Error flag' (X2) turns on. In addition, an error address is stored in 'Error address' (Un\G1). Turning on 'Error reset command' (Y2) clears the error code in 'Latest error code' (Un\G0), and 'Error flag' (X2) turns off.

Error codes of the temperature control module are classified into minor errors or moderate errors.

- Minor error: This error is caused by setting failures of programs or parameters, or incorrect execution timing. After the error cause is eliminated as a result of reviewing programs, each function can be normally executed. (1000H to 1FFFH)
- Moderate error: An error such as a hardware failure. The module does not continue the temperature control. (3000H to 3FFFH)

The following table lists the error codes to be stored.

□ in error codes: This symbol indicates the number of the channel where an error has occurred. (1: CH1, 2: CH2, 3: CH3, 4: CH4)

△ in error codes: For what this symbol indicates, refer to the Description and cause column.

Error code	Error name	Description and cause	Action
180△H	Interrupt factor generation setting range error	A value other than 0 and 1 has been stored in Interrupt factor generation setting [n]. △ indicates that the interrupt setting corresponding to the error is as follows: 0: Setting 1 to F: Setting 16	Set Interrupt factor generation setting [n] to 0 or 1.
181△H	Condition target setting range error	A value other than 0 to 12 has been stored in Condition target setting [n]. △ indicates that the interrupt setting corresponding to the error is as follows: 0: Setting 1 to F: Setting 16	Set Condition target setting [n] to a value within the range of 0 to 12.
182△H	Condition target channel setting range error	A value other than 0 to 4 has been stored in Condition target channel setting [n]. △ indicates that the interrupt setting corresponding to the error is as follows: 0: Setting 1 to F: Setting 16	Set Condition target channel setting [n] to a value within the range of 0 to 4.
1900H	Write error in the operation mode	Writing a value to the area where writing is allowed only in the setting mode was attempted in the operation mode.	Follow the instructions below to reset the error. 1: Change the mode to the setting mode. 2: Set the correct value and turn on and off 'Setting change command' (YB). When switching the mode from the operation mode to the setting mode, check that PID continuation flag is Stop (0), and turn on and off 'Setting/operation mode command' (Y1).
1910H	Set value discrepancy error (control mode)	The current control mode is different from the one backed up in the non-volatile memory because the control mode was changed.	Turn on and off 'Setting value backup command' (Y8).
1920H	Set value discrepancy error (control output cycle unit selection setting)	The current control output cycle unit is different from the one backed up in the non-volatile memory because the control output cycle unit was changed.	
1930H	Set value discrepancy error (sampling cycle)	The current sampling cycle is different from the one backed up in the non-volatile memory because the sampling cycle was changed.	
1940H	Setting change error during default setting registration	The setting value has been changed while 'Default setting registration command' (Y9) is on.	After turning on and off 'Error reset command' (Y2), change the setting value.
1950H	Setting out of range error	Data out of the setting range is being written. ^{*1}	Set data within the range.
1A0□H	CH□ Upper/lower limit output limiter setting error	The value set in CH□ Lower limit output limiter is equal to or greater than the value set in CH□ Upper limit output limiter.	Set the value so that the upper limit value is greater than the lower limit value.
1A1□H	CH□ Upper/lower limit setting limiter setting error	The value set in CH□ Lower limit setting limiter is equal to or greater than the value set in CH□ Upper limit setting limiter.	Set the value so that the upper limit value is greater than the lower limit value.

Error code	Error name	Description and cause	Action
1A△□H	CH□ Sensor two-point correction setting error	<p>The set values do not satisfy the following conditions.</p> <ul style="list-style-type: none"> • Sensor two-point correction offset value (measured value) < Sensor two-point correction gain value (measured value) • Sensor two-point correction offset value (corrected value) < Sensor two-point correction gain value (corrected value) <p>△ indicates the magnitude relation between the set values as follows:</p> <ol style="list-style-type: none"> 2: Sensor two-point correction offset value (measured value) ≥ Sensor two-point correction gain value (measured value) 3: Sensor two-point correction offset value (corrected value) ≥ Sensor two-point correction gain value (corrected value) 	<p>Set the values that meet the following conditions.</p> <ul style="list-style-type: none"> • Sensor two-point correction offset value (measured value) < Sensor two-point correction gain value (measured value) • Sensor two-point correction offset value (corrected value) < Sensor two-point correction gain value (corrected value)
1A7□H	CH□ Auto tuning error	The temperature process value (PV) is out of the input range.	<p>After turning on and off 'Error reset command' (Y2), execute the auto tuning again considering the following points.</p> <ul style="list-style-type: none"> • Set the AT bias so that the temperature process value (PV) during AT does not get out of the input range. • Check the upper limit output limiter value. If the value is 100% or greater, change the value. • For controlled objects with a high-speed response, the temperature process value (PV) may get out of the input range when the standard mode has been set in Auto tuning mode selection. In this case, set the high response mode in Auto tuning mode selection.
1A8□H	CH□ Auto tuning error	The set value (SV) or the AT point is out of the upper/lower limit setting limiter range.	After turning on and off 'Error reset command' (Y2), set a set value (SV), an AT point, or an upper/lower limit setting limiter so that the set value (SV) or the AT point is within the upper/lower limit setting limiter range, and execute the auto tuning again.
1A9□H	CH□ Auto tuning error	The proportional band has been set to 0.	After turning on and off 'Error reset command' (Y2), set the proportional band to a value other than 0, and execute the auto tuning again.
1AA□H	CH□ Auto tuning error	Settings of the buffer memory areas where changing the settings is not allowed have been changed.	After turning on and off 'Error reset command' (Y2), execute the auto tuning again. While the auto tuning is being executed, do not change the settings of the buffer memory areas.
1AB□H	CH□ Auto tuning error	The auto tuning error judgment time has been exceeded. ^{*2}	<p>After turning on and off 'Error reset command' (Y2), set the auto tuning error judgment time longer, and execute the auto tuning again.</p> <ul style="list-style-type: none"> ■When the temperature process value (PV) does not reach the set value (SV) while the control output is on <ul style="list-style-type: none"> • Check the heater has been powered on. • Check the upper limit output limiter value. If the value is smaller than 100%, change the value. ■When the temperature process value (PV) does not reach the set value (SV) while the control output is off <ul style="list-style-type: none"> • Check the lower limit output limiter value. If the value is greater than 0%, change the value. • The temperatures of the controlled objects may not fall due to effects of the environment. Stop the control of the adjacent controlled objects, and execute the auto tuning on each controlled object. <p>Even though the error still cannot be solved after the above actions are taken, manually set the PID constants. Or, change the heater capacity.</p>

Error code	Error name	Description and cause	Action
1AC□H	CH□ Auto tuning error	The PID constants calculation value is out of the allowable range.	<p>After turning on and off 'Error reset command' (Y2), take the following actions depending on the situation.</p> <p>■Proportional band < 1 Error cause: The amplitude of the control response during AT is small.</p> <ul style="list-style-type: none"> • Check the upper limit output limiter value. If the value is smaller than 100%, change the value. • Check the lower limit output limiter value. If the value is greater than 0%, change the value. • Change the input range to narrow the measured temperature range. <p>■Proportional band ≥ Full scale of the input range (in the R mode), Proportional band ≥ 10001 (when the Q compatible mode function is used) Error cause: The amplitude of the control response during AT is large.</p> <ul style="list-style-type: none"> • Change the upper limit output limiter value and the lower limit output limiter value to reduce the amplitude of the control response during AT. <p>■Integral time < 1 Error cause: The vibration cycle of the control response during AT is short.</p> <ul style="list-style-type: none"> • Set the upper limit output limiter larger and the lower limit output limiter smaller. • Check the setting of Auto tuning mode selection. When the high response mode has been set, change the mode to standard mode. <p>■Integral time ≥ 3601 Error cause: The vibration cycle of the control response during AT is long.</p> <ul style="list-style-type: none"> • Check the primary delay digital filter value and change it if necessary. • Check the value for number of moving average and change it if necessary. <p>[When the temperature process value (PV) does not decrease after exceeding the set value (SV)]</p> <ul style="list-style-type: none"> • Check the lower limit output limiter value. If the value is greater than 0%, change the value. • The temperatures of the controlled objects may not fall due to effects of the environment. Stop the control of the adjacent controlled objects, and execute the auto tuning on each controlled object. <p>[When the temperature process value (PV) does not increase after exceeding the set value (SV)]</p> <ul style="list-style-type: none"> • Check the upper limit output limiter value. If the value is smaller than 100%, change the value. <p>■Derivative time ≥ 3601 Error cause: The vibration cycle of the control response during AT is long.</p> <ul style="list-style-type: none"> • Set the integral time to 3600 or a smaller value.
1AD0H	Multiple module interaction function system error 1	At the initialization of the inter-module link function, an abnormal response has been detected in the data communication between the master temperature control module and the CPU module.	<ul style="list-style-type: none"> • Take measures to reduce noise. • Check that each module has been properly connected, and turn on the power supply again or reset the CPU module. When the same error occurs again, the possible cause is a module failure. Please consult your local Mitsubishi representative.
1AD1H	Multiple module interaction function system error 2	At the initialization of the inter-module link function, a system bus error has been detected.	<ul style="list-style-type: none"> • Take measures to reduce noise. • Check that the base unit and extension cables have been properly connected, and turn on the power supply again or reset the CPU module. When the same error occurs again, the possible cause is a module failure. Please consult your local Mitsubishi representative.
1AD2H	Multiple module interaction function system error 3	At the initialization of the inter-module link function, an abnormal response has been detected in the data communication between the master temperature control module and the other temperature control modules.	<ul style="list-style-type: none"> • Take measures to reduce noise. • Check that each module has been properly connected, and turn on the power supply again or reset the CPU module. When the same error occurs again, the possible cause is a module failure. Please consult your local Mitsubishi representative.

Error code	Error name	Description and cause	Action
1AE0H	Peak current suppression function master duplication error between multiple module	When the inter-module peak current suppression function has been enabled, two or more temperature control modules have been set as master modules.	When the inter-module peak current suppression function has been enabled for multiple modules, set only one module as the master module. (☞ Page 108 Inter-module peak current suppression function)
1AE1H	Peak current suppression function master not exist error between multiple module	<ul style="list-style-type: none"> When the inter-module peak current suppression function has been enabled, no module has been set as master module. After the inter-module peak current suppression function was initialized, the slave temperature control modules cannot receive data from the master temperature control module. 	When using the inter-module peak current suppression function, set only one of the modules to which the inter-module peak current suppression function has been enabled as the master module, and turn on the power supply again or reset the CPU module. (☞ Page 108 Inter-module peak current suppression function)
1AE2H	Peak current suppression function master communication error between multiple module	After the inter-module peak current suppression function was started (Y1 was turned on), an abnormal response has been detected in the data communication between the master temperature control module and the slave temperature control modules.	Check that each module has been properly connected, and turn on the power supply again or reset the CPU module.
1AE3H	Peak current suppression function slave reception error between multiple module	After the inter-module peak current suppression function was started (Y1 was turned on), the slave temperature control modules cannot receive data from the master temperature control module.	Check that each module has been properly connected, and turn on the power supply again or reset the CPU module.
1AE4H	Peak current suppression function start error between multiple module	After the inter-module peak current suppression function was started (Y1 was turned on), the slave temperature control modules cannot receive data from the master temperature control module.	Check that each module has been properly connected, and turn on the power supply again or reset the CPU module.
1AE5H	Peak current suppression function continuation error between multiple module	While the inter-module peak current suppression function is being performed, the slave temperature control modules cannot receive data from the master temperature control module.	Check that each module has been properly connected, and turn on the power supply again or reset the CPU module.
1AF0H	Simultaneous temperature rise function master duplication error between multiple module	When the inter-module simultaneous temperature rise function has been enabled, two or more temperature control modules have been set as master modules.	When the inter-module simultaneous temperature rise function has been enabled for multiple modules, set only one module as the master module. (☞ Page 110 Inter-module simultaneous temperature rise function)
1AF1H	Simultaneous temperature rise function master not exist error between multiple module	<ul style="list-style-type: none"> When the inter-module simultaneous temperature rise function has been used, no module has been set as the master module. After the inter-module simultaneous temperature rise function was initialized, the slave temperature control modules cannot receive data from the master temperature control module. 	When using the inter-module simultaneous temperature rise function, set only one of the modules to which the simultaneous temperature rise function has been enabled as the master module, and turn on the power supply again or reset the CPU module. (☞ Page 110 Inter-module simultaneous temperature rise function)
1AF2H	Simultaneous temperature rise function master communication error between multiple module	After the inter-module simultaneous temperature rise function was started (Y1 was turned on), an abnormal response has been detected in the data communication between the master temperature control module and the slave temperature control modules.	Check that each module has been properly connected, and turn on the power supply again or reset the CPU module.
1AF3H	Simultaneous temperature rise function slave reception error between multiple module	After the inter-module simultaneous temperature rise function was started (Y1 was turned on), the slave temperature control modules cannot receive data from the master temperature control module.	Check that each module has been properly connected, and turn on the power supply again or reset the CPU module.
3001H	Hardware failure	A hardware failure has occurred in the module.	<ul style="list-style-type: none"> Check that the terminal block or the cold junction temperature compensation resistor has not been disconnected or loose. Power off and on the module. When the same error occurs again, the possible cause is a module failure. Please consult your local Mitsubishi representative.

*1 The address of buffer memory area where a value out of the setting range is set can be checked with 'Error address' (Un\G1).

*2 If "Setting change rate limiter setting" is not 0, the time monitoring starts when Set value (SV) monitor becomes equal to the AT point.

3.5 List of Alarm Codes

If an alarm occurs in operation of the temperature control module, the alarm code of the alarm is stored into 'Latest alarm code' (Un\G3) of the buffer memory. Turning on and off 'Error reset command' (Y2) clears the alarm code in 'Latest alarm code' (Un\G3).

□ in alarm codes: This symbol indicates the number of the channel where an alarm has occurred. (1: CH1, 2: CH2, 3: CH3, 4: CH4)

Alarm code	Alarm name	Description and cause	Action
080□H	CH□ Process value (PV) out of input range (upper limit)	The temperature process value (PV) has exceeded the temperature measuring range that was set as the input range.	After the temperature process value (PV) falls within the setting range, turn on and off 'Error reset command' (Y2) to clear the alarm code stored in 'Latest alarm code' (Un\G3).
081□H	CH□ Process value (PV) out of input range (lower limit)	The temperature process value (PV) is below the temperature measuring range that was set as the input range.	After the temperature process value (PV) falls within the setting range, the corresponding bit of Alert definition and 'CH□ Alert flag' (XC to XF) automatically turn off.
082□H	CH□ Rate alarm (upper limit)	A rate alarm (upper limit) has occurred.	After the temperature process value (PV) is restored from the alert status, turn on and off 'Error reset command' (Y2) to clear the alarm code stored in 'Latest alarm code' (Un\G3).
083□H	CH□ Rate alarm (lower limit)	A rate alarm (lower limit) has occurred.	After the temperature process value (PV) is restored from the alert status, the corresponding bit of Alert definition and 'CH□ Alert flag' (XC to XF) automatically turn off.
084□H	CH□ Alert 1	Alert 1 has occurred.	After the temperature process value (PV) is restored from the alert status, turn on and off 'Error reset command' (Y2) to clear the alarm code stored in 'Latest alarm code' (Un\G3).
085□H	CH□ Alert 2	Alert 2 has occurred.	
086□H	CH□ Alert 3	Alert 3 has occurred.	
087□H	CH□ Alert 4	Alert 4 has occurred.	
088□H	CH□ Heater disconnection detection	A heater disconnection has been detected.	After the detected disconnection or the detected output off-time current error is resolved, turn on and off 'Error reset command' (Y2) to clear the alarm code stored in 'Latest alarm code' (Un\G3).
089□H	CH□ Loop disconnection detection	A loop disconnection has been detected.	
08A□H	CH□ Output off-time current error detection	An output off-time current error has been detected.	After the detected disconnection or the detected output off-time current error is resolved, the corresponding bit of Alert definition and 'CH□ Alert flag' (XC to XF) automatically turn off.

APPENDICES

Appendix 1 Module Label

The functions of the temperature control module can be set by using module labels.

Module labels of I/O signals

The module label name of an I/O signal is defined with the following structure.

"Module name"_"Module number"."Label name"

Ex.

R60TC_1.bModuleREADY

■Module name

This part indicates a module model name.

■Module number

A number starting from 1 is added to identify modules that have the same module name.

■Label name

This part indicates a label name unique to the module.

■_D

This string indicates that the module label is for the direct access input (DX) or direct access output (DY). A module label without this string is for the input (X) or output (Y) of refresh processing.

Module labels of buffer memory areas

The module label name of a buffer memory area is defined with the following structure.

"Module name"_"Module number"."Data type"_Ch ["(Channel)"]."Data format""Label name"_D

Ex.

R60TC_1.stnMonitor_Ch[0].wTemperatureProcessValue

■Module name

This part indicates a module model name.

■Module number

A number starting from 1 is added to identify modules that have the same module name.

■Data type

This part indicates the data type of the buffer memory area. The following table lists data types.

Data type	Description
stnMonitor	Monitor
stnControl	Control
stnSetting	Setting

■Channel

This part indicates the channel number corresponding to a module label. A numerical value of 0 to 3 is stored to correspond to CH1 to CH4.

(CH1: 0, CH2: 1, CH3: 2, CH4: 3)

■Data format

This part indicates the data size of the buffer memory area. The following table lists data types.

Data format	Description
u	Word [Unsigned]/Bit string [16 bits]
w	Word [Signed]
z	System area

■Label name

This part indicates a label name unique to the module.

■_D

This string indicates that the module label is for direct access. A module label without this string is for auto refresh. The following table shows the differences between auto refresh and direct access.

Type	Description	Access timing	Example
Auto refresh	The values read/written from/to a module label are reflected to the module in a batch at auto refresh. The run time of a program can be reduced. To use the auto refresh, set "Target" to "Module Label" in "Refresh" of "Module Parameter".	At auto refresh	R60TC_1.stErrorInfo.uLatest ErrorCode
Direct access	The values read/written from/to a module label are immediately reflected to the module. The run time of a program is longer than the one for auto refresh. However, the responsiveness is high.	At reading/writing from/to the module label	R60TC_1.stErrorInfo_D.uLat estErrorCode_D

Appendix 2 I/O Signal

List of I/O signals

The following table lists the I/O signals of the temperature control module.

For details on the I/O signals, refer to the following.

☞ Page 150 Details of input signals

☞ Page 158 Details of output signals

Point

- The following I/O numbers (X/Y) are for the case when the start I/O number of the temperature control module is set to 0.
- Do not use the following "use prohibited" signals because the system uses the signals. If users use (turn off or on) the signals, the functions of the temperature control module cannot be guaranteed.

Input signal

Device No.	Signal name			
	Standard control	Heating-cooling control	Mix control	Position proportional control
X0	Module READY flag	Module READY flag	Module READY flag	Module READY flag
X1	Setting/operation mode status	Setting/operation mode status	Setting/operation mode status	Setting/operation mode status
X2	Error flag	Error flag	Error flag	Error flag
X3	Hardware error flag	Hardware error flag	Hardware error flag	Hardware error flag
X4	CH1 Auto tuning status	CH1 Auto tuning status	CH1 Auto tuning status	CH1 Auto tuning status
X5	CH2 Auto tuning status	CH2 Auto tuning status	CH2 Auto tuning status ^{*1}	CH2 Auto tuning status
X6	CH3 Auto tuning status	CH3 Auto tuning status ^{*2}	CH3 Auto tuning status	CH3 Auto tuning status ^{*3}
X7	CH4 Auto tuning status	CH4 Auto tuning status ^{*2}	CH4 Auto tuning status	CH4 Auto tuning status ^{*3}
X8	Setting value backup completion flag	Setting value backup completion flag	Setting value backup completion flag	Setting value backup completion flag
X9	Default value write completion flag	Default value write completion flag	Default value write completion flag	Default value write completion flag
XA	Setting value backup failure flag	Setting value backup failure flag	Setting value backup failure flag	Setting value backup failure flag
XB	Setting change completion flag	Setting change completion flag	Setting change completion flag	Setting change completion flag
XC	CH1 Alert flag	CH1 Alert flag	CH1 Alert flag	CH1 Alert flag
XD	CH2 Alert flag	CH2 Alert flag	CH2 Alert flag	CH2 Alert flag
XE	CH3 Alert flag	CH3 Alert flag	CH3 Alert flag	CH3 Alert flag
XF	CH4 Alert flag	CH4 Alert flag	CH4 Alert flag	CH4 Alert flag

*1 Available only under the mix control (expanded mode).

*2 Available only under the heating-cooling control (expanded mode).

*3 Available only under the position proportional control (expanded mode).

Output signal

Device No.	Signal name			
	Standard control	Heating-cooling control	Mix control	Position proportional control
Y0	N/A	N/A	N/A	N/A
Y1	Setting/operation mode command	Setting/operation mode command	Setting/operation mode command	Setting/operation mode command
Y2	Error reset command	Error reset command	Error reset command	Error reset command
Y3	N/A	N/A	N/A	N/A
Y4	CH1 Auto tuning command	CH1 Auto tuning command	CH1 Auto tuning command	CH1 Auto tuning command
Y5	CH2 Auto tuning command	CH2 Auto tuning command	CH2 Auto tuning command ^{*1}	CH2 Auto tuning command
Y6	CH3 Auto tuning command	CH3 Auto tuning command ^{*2}	CH3 Auto tuning command	CH3 Auto tuning command ^{*3}
Y7	CH4 Auto tuning command	CH4 Auto tuning command ^{*2}	CH4 Auto tuning command	CH4 Auto tuning command ^{*3}
Y8	Setting value backup command	Setting value backup command	Setting value backup command	Setting value backup command
Y9	Default setting registration command	Default setting registration command	Default setting registration command	Default setting registration command
YA	N/A	N/A	N/A	N/A
YB	Setting change command	Setting change command	Setting change command	Setting change command
YC	CH1 PID control forced stop command	CH1 PID control forced stop command	CH1 PID control forced stop command	CH1 PID control forced stop command
YD	CH2 PID control forced stop command	CH2 PID control forced stop command	CH2 PID control forced stop command ^{*1}	CH2 PID control forced stop command
YE	CH3 PID control forced stop command	CH3 PID control forced stop command ^{*2}	CH3 PID control forced stop command	CH3 PID control forced stop command ^{*3}
YF	CH4 PID control forced stop command	CH4 PID control forced stop command ^{*2}	CH4 PID control forced stop command	CH4 PID control forced stop command ^{*3}

*1 Available only under the mix control (expanded mode).

*2 Available only under the heating-cooling control (expanded mode).

*3 Available only under the position proportional control (expanded mode).

Details of input signals

This section describes the details of the input signals of the temperature control module to the CPU module.

The I/O numbers (X/Y) described in this section are for the case when the start I/O number of the temperature control module is set to 0.

Module READY flag

This flag turns on to indicate that the preparation for the temperature control module is completed after the module is powered off and on or the CPU module is reset and the reset is canceled.

Check that this flag is on when reading or writing data from/to the buffer memory areas of the temperature control module from the CPU module.

The following shows a program example. (In the program example shown below, the start I/O number of the temperature control module has been set to 10.)

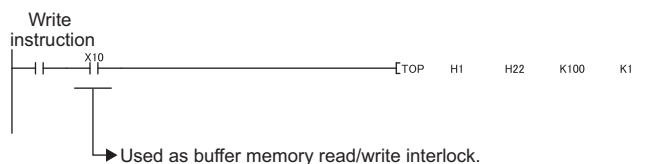

When a watchdog timer error is detected, this flag turns off. The temperature control module stops the temperature control operation and the transistor output is also turned off (The RUN LED turns off and the ERR LED turns on).

Device No.

The following shows the device number of this input signal.

Signal name	CH1 to CH4
Module READY flag	X0

Setting/operation mode status

This signal is on in the operation mode and off in the setting mode.

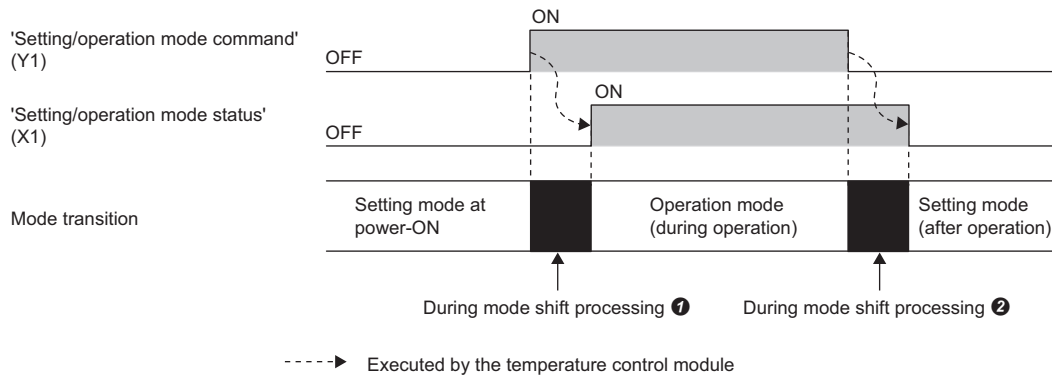

■Precautions during the mode shift processing

The mode shift processing means the following timings.

- From when 'Setting/operation mode command' (Y1) is turned on until when 'Setting/operation mode status' (X1) turns on (① in the figure above)
- From when 'Setting/operation mode command' (Y1) is turned off until when 'Setting/operation mode status' (X1) turns off (② in the figure above)

During the mode shift processing, do not change the set values. If the set values are changed during the mode shift processing, operations of the module cannot be guaranteed. Use 'Setting/operation mode status' (X1) as an interlock condition for 'Setting/operation mode command' (Y1) when changing the set values.

Point

The conditions to determine whether to execute the temperature judgment, PID control, and alert judgment to be executed by the temperature control module differ among the following timings.

- Setting mode at power-on
- Operation mode (during operation)
- Setting mode (after operation)

For details on the temperature judgment, PID control, and alert judgment, refer to the following.

- Temperature judgment (☞ Page 224 CH1 Alert definition)
- PID control (☞ Page 20 Condition to execute the PID control)
- Alert judgment (☞ Page 76 Condition for alert judgment)

■Device No.

The following shows the device number of this input signal.

Signal name	CH1 to CH4
Setting/operation mode status	X1

A

Error flag

This flag turns on when an error other than a hardware error occurs.

After an error occurs and the error code of the error is stored in 'Latest error code' (Un\G0), this flag turns on.

An error occurs under the following conditions.

- When data is set in a system area of the buffer memory
- When the setting in the area where writing is enabled only in the setting mode ('Setting/operation mode status' (X1): Off) is changed in the operation mode ('Setting/operation mode status' (X1): On)
- When the data that cannot be set is set
- When settings in the buffer memory are changed while the default settings have been registered

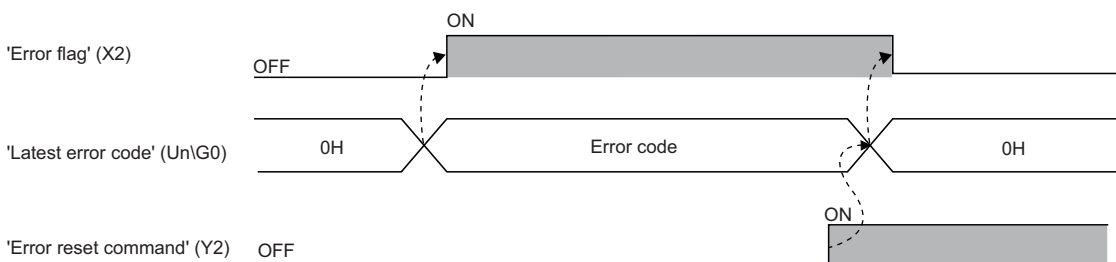

-----▶ Executed by the temperature control module

■Device No.

The following shows the device number of this input signal.

Signal name	CH1 to CH4
Error flag	X2

Hardware error flag

This flag turns on when a hardware failure occurs in the temperature control module.

■Device No.

The following shows the device number of this input signal.

Signal name	CH1 to CH4
Hardware error flag	X3

Auto tuning status

This signal turns on when users execute the auto tuning of each channel or when the temperature control module executes the self-tuning.

Channel	Auto tuning status				ON/OFF state
	Standard control	Heating-cooling control	Mix control	Position proportional control	
CH1	X4	X4	X4	X4	On: During auto tuning/self-tuning Off: The auto tuning/self-tuning has not been executed or is completed.
CH2	X5	X5	X5 ^{*1}	X5	
CH3	X6	X6 ^{*1}	X6	X6 ^{*1}	
CH4	X7	X7 ^{*1}	X7	X7 ^{*1}	

*1 Available only in the expanded mode.

Execution of auto tuning

To execute the auto tuning, turn on 'CH1 Auto tuning command' (Y4).

This signal is on during the auto tuning, and automatically turns off at the completion of the auto tuning.

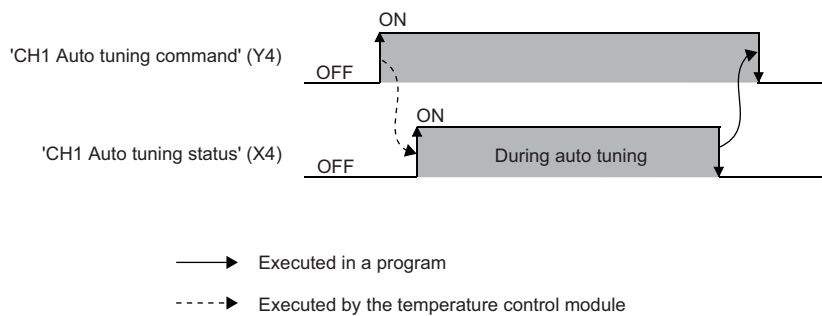

For details on the auto tuning function, refer to the following.

📖 Page 35 Auto Tuning Function

A

Point

This signal turns on when the self-tuning starts. This signal automatically turns off at the completion of the self-tuning.

Set a self-tuning option in 'CH1 Self-tuning setting' (Un\G548).

The self-tuning can be executed only in the standard control.

For details on the self-tuning function, refer to the following.

📖 Page 44 Self-tuning Function

Device No.

The following shows the device number of this input signal.

Signal name	CH1	CH2	CH3	CH4
Auto tuning status	X4	X5	X6	X7

Setting value backup completion flag

Turning off and on 'Setting value backup command' (Y8) starts the writing of the data in the buffer memory to the non-volatile memory. After the data writing is completed, this flag turns on. Turning off 'Setting value backup command' (Y8) also turns off this flag.

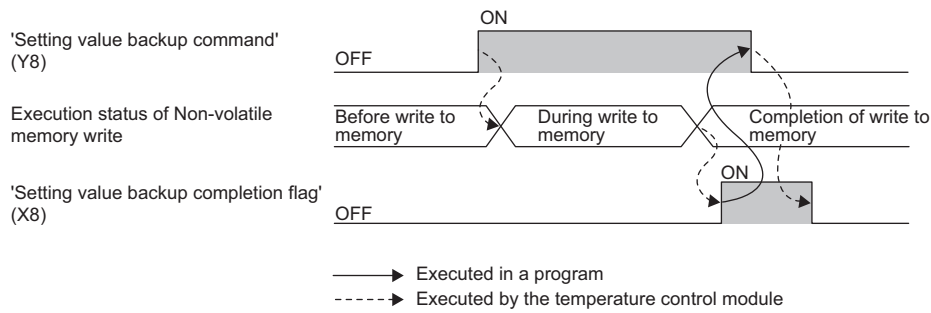

For details on the data writing to the non-volatile memory, refer to the following.

📖 Page 119 Buffer Memory Data Backup Function

■Device No.

The following shows the device number of this input signal.

Signal name	CH1 to CH4
Setting value backup completion flag	X8

Default value write completion flag

Turning off and on 'Default setting registration command' (Y9) starts the writing of the default value of the temperature control module to the buffer memory.

After the default value writing is completed, this flag turns on. Turning off 'Default setting registration command' (Y9) also turns off this flag.

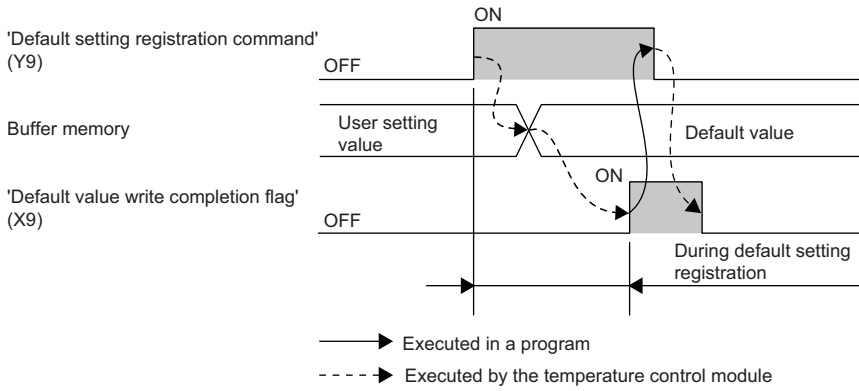

■Unused channel

For unused channels (where temperature sensors are not connected), set 'CH1 Unused channel setting' (Un\G502) to Unused (1) after the completion of the writing of the default values.

When 'CH1 Unused channel setting' (Un\G502) is not set to Unused (1), the ALM LED flashes.

For details on the unused channels, refer to the following.

📖 Page 32 Temperature Conversion Function (Using Unused Channels)

■Device No.

The following shows the device number of this input signal.

Signal name	CH1 to CH4
Default value write completion flag	X9

A

Setting value backup failure flag

Turning off and on 'Setting value backup command' (Y8) writes the data in the buffer memory to the non-volatile memory. This flag turns on when the writing to the non-volatile memory has failed.

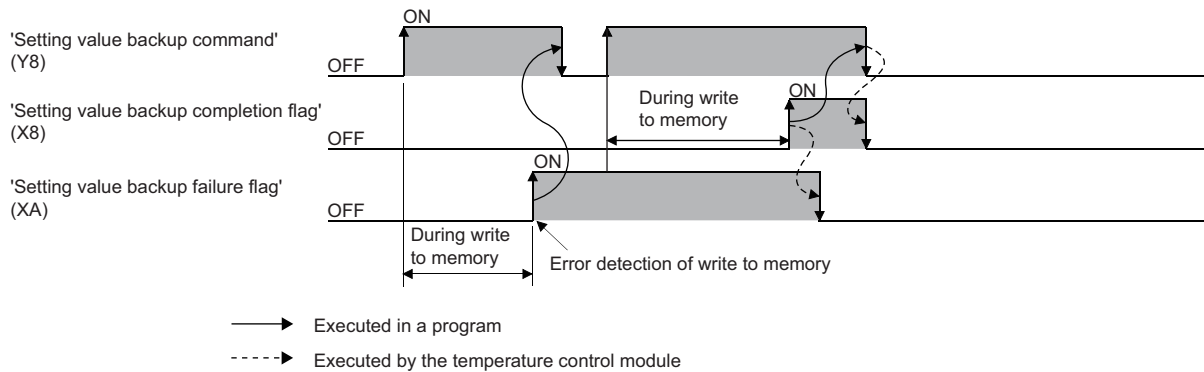

After turning on 'Setting value backup command' (Y8) again and the data writing to the non-volatile memory is completed successfully, this flag turns off. For details on the data writing to the non-volatile memory, refer to the following.

📖 Page 119 Writing data to the non-volatile memory

Point

When an error of the data read from the non-volatile memory is detected at power-on, 'Setting value backup failure flag' (XA) turns on and the temperature control module operates with the default values.

In this case, turn off and on 'Setting value backup command' (Y8) and write the settings to the non-volatile memory.

When the data writing fails again, a hardware failure has occurred. Please consult your local Mitsubishi representative.

Device No.

The following shows the device number of this input signal.

Signal name	CH1 to CH4
Setting value backup failure flag	XA

Setting change completion flag

Turning off and on 'Setting change command' (YB) in the setting mode ('Setting/operation mode status' (X1): Off) reflects the value set in each buffer memory area to the controls. After the data is reflected, this flag turns on. Turning off 'Setting change command' (YB) also turns off this flag.

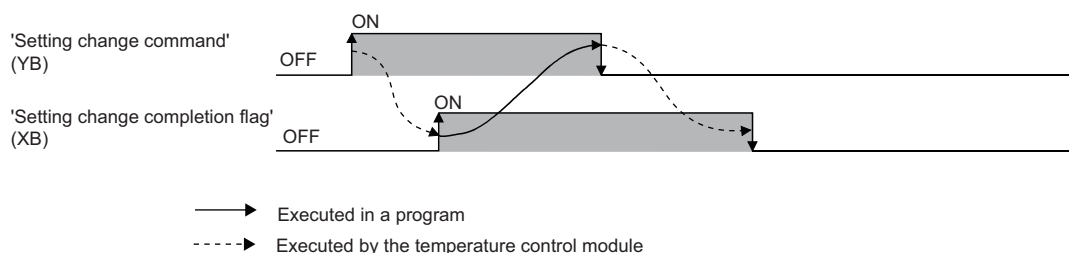

This flag can be used as an interlock of 'Setting/operation mode command' (Y1).

Device No.

The following shows the device number of this input signal.

Signal name	CH1 to CH4
Setting change completion flag	XB

Alert flag

When an alert has occurred in CH1, the alert definition is stored in 'CH1 Alert definition' (Un\G401), and this flag turns on. For the conditions where this flag turns off, refer to the following.

☞ Page 76 Condition in which 'CH1 Alert flag' (XC) turns off

The following table lists the flags and buffer memory addresses of alert definitions for each channel.

Channel	Alert flag	Buffer memory address	ON/OFF state
CH1	XC	Un\G401	Off: No alert has occurred. On: An alert has occurred.
CH2	XD	Un\G601	
CH3	XE	Un\G801	
CH4	XF	Un\G1001	

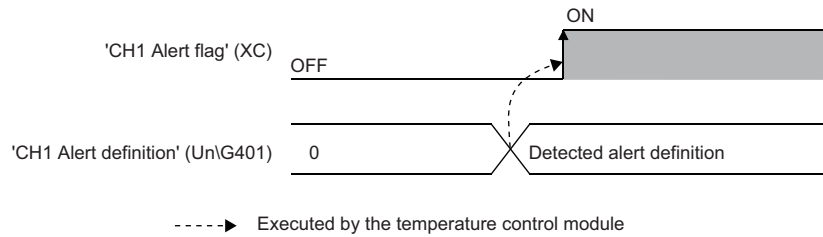

■Device No.

The following shows the device number of this input signal.

Signal name	CH1	CH2	CH3	CH4
Alert flag	XC	XD	XE	XF

Details of output signals

This section describes the details of the output signals of the temperature control module to the CPU module.

The I/O numbers (X/Y) described in this section are for the case when the start I/O number of the temperature control module is set to 0.

Setting/operation mode command

Use this signal to select the setting mode or the operation mode.

- Off: Setting mode
- On: Operation mode

Some buffer memory areas can be set only in the setting mode. The settings of four channels are configured in a batch.

■ Buffer memory areas that can be set only in the setting mode

The temperature control module has parameters that can be changed only when 'Setting/operation mode command' (Y1) is off. For the parameters that can be changed only in the setting mode, refer to the following. When the parameters are changed in the operation mode, a write error in the operation mode (error code: 1900H) occurs.

 Page 161 List of buffer memory addresses

■ Device No.

The following shows the device number of this output signal.

Signal name	CH1 to CH4
Setting/operation mode command	Y1

Error reset command

Use this signal to turn off 'Error flag' (X2) and to reset 'Latest error code' (Un\G0). For how to reset an error, refer to 'Error flag' (X2). ( Page 152 Error flag)

■ Device No.

The following shows the device number of this output signal.

Signal name	CH1 to CH4
Error reset command	Y2

Auto tuning command

Use this signal to start the auto tuning for each channel. Turning off and on 'CH1 Auto tuning command' (Y4) starts the auto tuning and turns on 'CH1 Auto tuning status' (X4). After the auto tuning is completed, 'CH1 Auto tuning status' (X4) turns off. Keep 'CH1 Auto tuning command' (Y4) on during the auto tuning, and turn off the signal at the completion of the auto tuning. If 'CH1 Auto tuning command' (Y4) is turned on and off during the auto tuning, the auto tuning will stop. When the auto tuning has stopped, the PID constants in the buffer memory do not change.

Point

- If 0 has been set for Proportional band (P) setting or Heating proportional band (Ph) setting, the auto tuning cannot be executed. ( Page 40 Conditions in which the auto tuning cannot be executed)
- When 'Setting/operation mode command' (Y1) is turned on and off and the mode shifts to the setting mode during the auto tuning, the auto tuning stops. After that, even though 'Setting/operation mode command' (Y1) is turned on and the mode shifts back to the operation mode, the auto tuning does not restart. To restart the auto tuning, turn off this command, and turn it on again.

For details on the auto tuning function, refer to the following.

 Page 35 Auto Tuning Function

■ Device No.

The following shows the device number of this output signal.

Signal name	CH1	CH2	CH3	CH4
Auto tuning command	Y4	Y5	Y6	Y7

Setting value backup command

Use this signal to write the data in the buffer memory to the non-volatile memory. Turning off and on this command starts the data writing to the non-volatile memory.

For the buffer memory areas whose data is to be backed up, refer to the following.

☞ Page 161 List of buffer memory addresses

■When the data writing to the non-volatile memory has been completed successfully

'Setting value backup completion flag' (X8) turns on.

■When the data writing to the non-volatile memory has not been completed successfully

'Setting value backup failure flag' (XA) turns on. When 'Setting value backup failure flag' (XA) has turned on, turn off and on this command again and write the data to the non-volatile memory.

■Timings when this command cannot be accepted

This command are not accepted at the following timings.

- 1: While PID constants are being written automatically after auto tuning
- 2: While PID constants are being read from the non-volatile memory
- 3: When a setting error has occurred
- 4: While a setting is being changed with 'Setting change command' (YB)

For 1 to 3 above, turn off and on this command again after each factor is cleared. For 4, the data writing to the non-volatile memory will automatically start when the factor is cleared.

For details on the data writing to the non-volatile memory, refer to the following.

☞ Page 119 Buffer Memory Data Backup Function

■Device No.

The following shows the device number of this output signal.

Signal name	CH1 to CH4
Setting value backup command	Y8

Default setting registration command

Turning off and on 'Default setting registration command' (Y9) returns the data in the buffer memory to the default values according to the control output cycle unit selection setting and the control mode setting. After the data writing is completed, 'Default value write completion flag' (X9) turns on. (☞ Page 161 List of buffer memory addresses)

■When 'Setting/operation mode status' (X1) is on (in the operation mode)

Turning off and on this command does not set back the data to the default values. Turn on this command when 'Setting/operation mode status' (X1) is off (in the setting mode).

■Reflection of set values

Usually, when the settings in the buffer memory have been changed, 'Setting change command' (YB) has to be turned on to reflect the changes of the input range, alert mode, or other settings. However, when 'Default setting registration command' (Y9) is turned on, the changes are reflected without turning on 'Setting change command' (YB).

■Device No.

The following shows the device number of this output signal.

Signal name	CH1 to CH4
Default setting registration command	Y9

Setting change command

Use this command to determine the values set in buffer memory areas (The buffer memory areas that can be set only in the setting mode ('Setting/operation mode status' (X1): Off)). ( Page 119 Buffer Memory Data Backup Function)

■Reflection of set values

Even though the set values are written into the buffer memory, they are not immediately reflected to the temperature control module's operation.

To determine the set values, turn on and off this command after the set values are written into the buffer memory.

Turning on and off this command operates the temperature control module according to the setting in each buffer memory area.

Point

This device can be used as an interlock of 'Setting/operation mode command' (Y1).

■Device No.

The following shows the device number of this output signal.

Signal name	CH1 to CH4
Setting change command	YB

PID control forced stop command

Use this signal to temporarily stop the PID control forcibly.

■Mode of when the PID control stops

The mode of when the PID control stops is determined in "Stop mode setting" of "Control basic parameters" in "Application Setting". ( Page 132 Application Setting)

Point

If the CPU module is turned from RUN to STOP while 'CH1 PID control forced stop command' (YC) is on, 'CH1 PID control forced stop command' (YC) turns off and the PID forced stop is cleared.

■Device No.

The following shows the device number of this output signal.

Signal name	CH1	CH2	CH3	CH4
PID control forced stop command	YC	YD	YE	YF

Appendix 3 Buffer Memory Areas

List of buffer memory addresses

The following table lists the buffer memory addresses of the temperature control module. For details on the buffer memory addresses, refer to the following.

 Page 207 Details of buffer memory addresses

The buffer memory areas of the temperature control module are classified into the following data types.

Data type	Description	
Setting data	Description	Set this data according to the connected device and application of the system.
	Write/read attribute	Data can be read and written from/to this area.
	Setting method	Set this data using an engineering tool or a program.
	Setting timing	After changing values, turn on and off 'Setting change command' (YB) to enable the set values.
Control data	Description	Use this data to control the temperature control module.
	Write/read attribute	Data can be read and written from/to this area.
	Setting method	Set this data using an engineering tool or a program.
	Setting timing	As soon as values are changed, the set values become effective.
Monitor data	Description	Use this data to monitor the status of the temperature control module.
	Write/read attribute	Reading data is only allowed. Writing data is not allowed.
	Setting method	—
	Setting timing	—

Point

- Among the buffer memory areas, do not write data in the system areas or the areas whose data types are monitor data. Writing data into these areas can cause the malfunction of the module.

In the R mode

The following table describes the items (1) to (5) in the list of buffer memory addresses.

No.	Item
(1)	Automatic setting target
(2)	Target saved in the non-volatile memory
(3)	Default setting registration command
(4)	Setting change command
(5)	Auto refresh

■Un\G0 to Un\G3919

Address: Decimal (hexadecimal)	CH	Setting details				Default value	Data type	(1)	(2)	(3)	(4)	(5)
		Standard control	Heating- cooling control	Mix control	Position- proportional control							
0(0H)	All	Latest error code				0	Monitor	—	—	—	—	○
1(1H)	All	Error address				0	Monitor	—	—	—	—	○
2(2H)	All	Latest address of error history				0	Monitor	—	—	—	—	○
3(3H)	All	Latest alarm code				0	Monitor	—	—	—	—	○
4(4H)	All	Latest address of alarm history				0	Monitor	—	—	—	—	○
5 to 20 (5H to 14H)	All	Interrupt factor detection flag [n] ^{*10}				0	Monitor	—	—	—	—	○
21 to 36 (15H to 24H)	—	System area				—	—	—	—	—	—	—
37(25H)	All	Control mode selection monitor				0	Monitor	—	—	—	—	—
38(26H)	All	Sampling cycle monitor				0	Monitor	—	—	—	—	—
39(27H)	All	Automatic setting monitor at input range change				0	Monitor	—	—	—	—	—
40(28H)	All	Setting variation rate limiter setting selection monitor				0	Monitor	—	—	—	—	—
41(29H)	All	Control output cycle unit monitor			System area	0	Monitor	—	—	—	—	—
42(2AH)	All	Moving average processing setting monitor				0	Monitor	—	—	—	—	—
43(2BH)	All	Temperature conversion completion flag				0	Monitor	—	—	—	—	○
44(2CH)	All	MAN mode shift completion flag			System area	0	Monitor	—	—	—	—	—
45(2DH)	All	Cold junction temperature process value*1				0	Monitor	—	—	—	—	—
46(2EH)	All	Memory's PID constants read completion flag				0	Monitor	—	—	—	—	—
47(2FH)	All	Memory's PID constants write completion flag				0	Monitor	—	—	—	—	—
48(30H)	All	Feed forward value memory read completion flag			System area	0	Monitor	—	—	—	—	—
49 to 123 (31H to 7BH)	—	System area				—	—	—	—	—	—	—
124 to 139 (7CH to 8BH)	All	Interrupt factor mask [n] ^{*10}				0	Control	—	—	—	—	—
140 to 155 (8CH to 9BH)	—	System area				—	—	—	—	—	—	—
156 to 171 (9CH to ABH)	All	Interrupt factor reset request [n] ^{*10}				0	Control	—	—	—	—	—
172 to 199 (ACH to C7H)	—	System area				—	—	—	—	—	—	—
200 to 215 (C8H to D7H)	All	Interrupt factor generation setting [n] ^{*10}				0	Setting	—	—	—	○	—
216 to 231 (D8H to E7H)	—	System area				—	—	—	—	—	—	—
232 to 247 (E8H to F7H)	All	Condition target setting [n] ^{*10}				0	Setting	—	—	—	○	—
248 to 263 (F8H to 107H)	—	System area				—	—	—	—	—	—	—
264 to 279 (108H to 117H)	All	Condition target channel setting [n] ^{*10}				0	Setting	—	—	—	○	—

Address: Decimal (hexadecimal)	CH	Setting details				Default value	Data type	(1)	(2)	(3)	(4)	(5)
		Standard control	Heating- cooling control	Mix control	Position- proportional control							
280 to 299 (118H to 12BH)	—	System area				—	—	—	—	—	—	—
300(12CH)	All	Control mode selection				0	Setting	—	○	—	○	—
301(12DH)	All	Sampling cycle selection				0	Setting	—	○	—	○	—
302(12EH)	All	Automatic setting at input range change				0	Setting	—	○	—	○	—
303(12FH)	All	Setting variation rate limiter setting selection				0	Setting	—	○	—	○	—
304(130H)	All	Control output cycle unit selection setting		System area	0	Setting	—	○	—	○	—	
305(131H)	All	Moving average processing setting				0	Setting	—	○	—	○	—
306(132H)	All	PID continuation flag				0	Setting	—	○	○	—	—
307(133H)	All	Transistor output monitor ON delay time setting				0	Setting	—	○	○	—	—
308(134H)	All	Manipulated value resolution change for output with another analog module		System area	0	Setting	—	○	○	○	—	
309(135H)	All	Cold junction temperature compensation selection ^{*1}				0	Setting	—	○	○	—	—
310 to 399 (136H to 18FH)	—	System area				—	—	—	—	—	—	—
400(190H)	CH1	Decimal point position				0(TCTRT) 1(TCRT)	Monitor	—	—	—	—	—
401(191H)	CH1	Alert definition				0	Monitor	—	—	—	—	○
402(192H)	CH1	Temperature process value (PV)				0	Monitor	—	—	—	—	○
403(193H)	CH1	Manipulated value (MV)	Manipulated value for heating (MVh)		System area	0	Monitor	—	—	—	—	○
404(194H)	CH1	Temperature rise judgment flag				0	Monitor	—	—	—	—	○
405(195H)	CH1	Transistor output flag	Heating transistor output flag		Open side transistor output flag	0	Monitor	—	—	—	—	○
406(196H)	CH1	Set value (SV) monitor				0	Monitor	—	—	—	—	○
407(197H)	CH1	Manipulated value (MV) for output with another analog module	Manipulated value for heating (MVh) for output with another analog module		System area	0	Monitor	—	—	—	—	○
408(198H)	CH1	System area	Manipulated value for cooling (MVc)		System area	0	Monitor	—	—	—	—	○
409(199H)	CH1	System area	Manipulated value for cooling (MVc) for output with another analog module		System area	0	Monitor	—	—	—	—	○
410(19AH)	CH1	System area	Cooling transistor output flag		Close side transistor output flag	0	Monitor	—	—	—	—	○
411(19BH)	CH1	Self-tuning flag	System area			0	Monitor	—	—	—	—	○
412(19CH)	CH1	Process value (PV) scaling value				0	Monitor	—	—	—	—	○
413(19DH)	CH1	AT simultaneous temperature rise parameter calculation flag	System area			0	Monitor	—	—	—	—	○
414(19EH)	CH1	Simultaneous temperature rise status	System area			0	Monitor	—	—	—	—	○
415(19FH)	CH1	Feed forward control forced start status		System area	0	Monitor	—	—	—	—	○	
416(1A0H)	CH1	Feed forward value tuning flag		System area	0	Monitor	—	—	—	—	○	
417(1A1H)	CH1	Feed forward control READY flag		System area	0	Monitor	—	—	—	—	○	
418(1A2H)	CH1	Feed forward control forced start READY flag		System area	0	Monitor	—	—	—	—	○	
419(1A3H)	CH1	Sensor two-point correction offset latch completion				0	Monitor	—	—	—	—	○
420(1A4H)	CH1	Sensor two-point correction gain latch completion				0	Monitor	—	—	—	—	○
421 to 429 (1A5H to 1ADH)	—	System area				—	—	—	—	—	—	—

Address: Decimal (hexadecimal)	CH	Setting details				Default value	Data type	(1)	(2)	(3)	(4)	(5)
		Standard control	Heating- cooling control	Mix control	Position- proportional control							
430(1AEH)	CH1	Set value (SV) setting				0	Control	○	○	○	—	—
431(1AFH)	CH1	Proportional band (P) setting	Heating proportional band (Ph) setting		Proportional band (P) setting	30	Control	○	○	○	—	—
432(1B0H)	CH1	Integral time (I) setting				240	Control	—	○	○	—	—
433(1B1H)	CH1	Derivative time (D) setting				60	Control	—	○	○	—	—
434(1B2H)	CH1	Alert set value 1				0	Control	○	○	○	—	—
435(1B3H)	CH1	Alert set value 2				0	Control	○	○	○	—	—
436(1B4H)	CH1	Alert set value 3				0	Control	○	○	○	—	—
437(1B5H)	CH1	Alert set value 4				0	Control	○	○	○	—	—
438(1B6H)	CH1	Temperature process value (PV) for input with another analog module				0	Control	—	—	○	—	—
439(1B7H)	CH1	System area	Cooling proportional band (Pc) setting		System area	30	Control	○	○	○	—	—
440(1B8H)	CH1	Memory's PID constants read command				0	Control	—	—	○	—	—
441(1B9H)	CH1	Feed forward value memory read command			System area	0	Control	—	—	○	—	—
442 to 499 (1BAH to 1F3H)	—	System area				—	—	—	—	—	—	—
500(1F4H)	CH1	HOLD/CLEAR setting				0	Setting	—	○	—	○	—
501(1F5H)	CH1	Input range				2(TCTRT) 7(TCRT)	Setting	—	○	○	○	—
502(1F6H)	CH1	Unused channel setting				0	Setting	—	○	○	—	—
503(1F7H)	CH1	Stop mode setting				1	Setting	—	○	○	—	—
504(1F8H)	CH1	Control output cycle setting	Heating control output cycle setting		System area	30 ^{*14} 300 ^{*15}	Setting	—	○	○	—	—
505(1F9H)	CH1	Control response parameter				0	Setting	—	○	○	—	—
506(1FAH)	CH1	Temperature rise completion range setting				1	Setting	—	○	○	—	—
507(1FBH)	CH1	Temperature rise completion soak time setting				0	Setting	—	○	○	—	—
508(1FCH)	CH1	Upper limit output limiter	Heating upper limit output limiter		System area	1000	Setting	—	○	○	—	—
509(1FDH)	CH1	Lower limit output limiter	System area			0	Setting	—	○	○	—	—
510(1FEH)	CH1	Output variation amount limiter			System area	0	Setting	—	○	○	—	—
511(1FFH)	CH1	Upper limit setting limiter				1300(TCTRT) 6000(TCRT)	Setting	○	○	○	—	—
512(200H)	CH1	Lower limit setting limiter				0(TCTRT) -2000(TCRT)	Setting	○	○	○	—	—
513(201H)	CH1	Setting variation rate limiter/setting variation rate limiter (temperature rise) ^{*2}				0	Setting	—	○	○	—	—
514(202H)	CH1	Setting variation rate limiter (temperature drop) ^{*3}				0	Setting	—	○	○	—	—
515(203H)	CH1	Direct/reverse action setting	System area		Direct/reverse action setting	1	Setting	—	○	○	—	—
516(204H)	CH1	Adjustment sensitivity (dead band) setting				5	Setting	—	○	○	—	—
517(205H)	CH1	Manual reset amount setting			System area	0	Setting	—	○	○	—	—
518(206H)	CH1	AUTO/MAN mode shift			System area	0	Setting	—	○	○	—	—
519(207H)	CH1	MAN output setting			System area	0	Setting	—	○	○	—	—
520(208H)	CH1	System area				—	—	—	—	—	—	—
521(209H)	CH1	System area	Cooling upper limit output limiter		System area	1000	Setting	—	○	○	—	—
522(20AH)	CH1	System area	Cooling control output cycle setting		System area	30 ^{*14} 300 ^{*15}	Setting	—	○	○	—	—
523(20BH)	CH1	System area	Cooling method setting		System area	0	Setting	—	○	○	○	—
524(20CH)	CH1	System area	Overlap/dead band setting		System area	0	Setting	—	○	○	—	—
525(20DH)	CH1	Derivative action selection			System area	0	Setting	—	○	○	○	—
526(20EH)	CH1	Setting variation rate limiter unit time setting				0	Setting	—	○	○	○	—

Address: Decimal (hexadecimal)	CH	Setting details				Default value	Data type	(1)	(2)	(3)	(4)	(5)
		Standard control	Heating- cooling control	Mix control	Position- proportional control							
527(20FH)	CH1	System area			Open/close output neutral band setting	20	Setting	—	○	○	○	—
528(210H)	CH1	System area			Control motor time	10	Setting	—	○	○	○	—
529(211H)	CH1	System area			Integration output limiter setting	1500	Setting	—	○	○	○	—
530(212H)	CH1	System area			Valve operation setting during CPU module STOP	0	Setting	—	○	○	○	—
531(213H)	CH1	Alert dead band setting				5	Setting	○	○	○	—	—
532(214H)	CH1	Number of alert delay				0	Setting	—	○	○	—	—
533(215H)	CH1	Alert 1 mode setting				0	Setting	—	○	○	○	—
534(216H)	CH1	Alert 2 mode setting				0	Setting	—	○	○	○	—
535(217H)	CH1	Alert 3 mode setting				0	Setting	—	○	○	○	—
536(218H)	CH1	Alert 4 mode setting				0	Setting	—	○	○	○	—
537(219H)	CH1	Loop disconnection detection judgment time	System area			480	Setting	—	○	○	—	—
538(21AH)	CH1	Loop disconnection detection dead band	System area			0	Setting	○	○	○	—	—
539(21BH)	CH1	Rate alarm alert output enable/disable setting				1	Setting	—	○	○	○	—
540(21CH)	CH1	Rate alarm alert detection cycle				1	Setting	—	○	○	○	—
541(21DH)	CH1	Rate alarm upper limit value				0	Setting	—	○	○	○	—
542(21EH)	CH1	Rate alarm lower limit value				0	Setting	—	○	○	○	—
543(21FH)	CH1	Auto tuning mode selection				0	Setting	—	○	○	—	—
544(220H)	CH1	Auto tuning error judgment time				120	Setting	—	○	○	—	—
545(221H)	CH1	During AT loop disconnection detection function enable/ disable	System area			0	Setting	—	○	○	—	—
546(222H)	CH1	AT bias				0	Setting	○	○	○	—	—
547(223H)	CH1	Automatic backup setting after auto tuning of PID constants				0	Setting	—	—	○	—	—
548(224H)	CH1	Self-tuning setting	System area			0	Setting	—	○	○	—	—
549(225H)	CH1	Process value (PV) scaling function enable/disable setting				0	Setting	—	○	○	○	—
550(226H)	CH1	Process value (PV) scaling upper limit value				0	Setting	—	○	○	○	—
551(227H)	CH1	Process value (PV) scaling lower limit value				0	Setting	—	○	○	○	—
552(228H)	CH1	Peak current suppression control group setting	System area			0	Setting	—	○	○	○	—
553(229H)	CH1	Simultaneous temperature rise group setting	System area			0	Setting	—	○	○	○	—
554(22AH)	CH1	Simultaneous temperature rise gradient data	System area			0	Setting	○	○	○	—	—
555(22BH)	CH1	Simultaneous temperature rise dead time	System area			0	Setting	○	○	○	—	—

Address: Decimal (hexadecimal)	CH	Setting details				Default value	Data type	(1)	(2)	(3)	(4)	(5)
		Standard control	Heating- cooling control	Mix control	Position- proportional control							
556(22CH)	CH1	Simultaneous temperature rise AT mode selection	System area			0	Setting	—	○	○	—	—
557(22DH)	CH1	Disturbance judgment position		System area	0	Setting	○	○	○	—	—	
558(22EH)	CH1	Set value return adjustment			System area	0	Setting	—	○	○	—	—
559(22FH)	CH1	Feed forward control forced starting signal			System area	0	Setting	—	—	○	—	—
560(230H)	CH1	Feed forward value			System area	0	Setting	—	○	○	—	—
561(231H)	CH1	Feed forward value tuning selection			System area	0	Setting	—	—	○	—	—
562(232H)	CH1	Overshoot suppression level setting			0	Setting	—	○	○	—	—	
563(233H)	CH1	Primary delay digital filter setting			0	Setting	—	○	○	—	—	
564(234H)	CH1	Sensor correction function selection			0	Setting	—	○	○	○	—	
565(235H)	CH1	Sensor correction value setting			0	Setting	—	○	○	—	—	
566(236H)	CH1	Sensor two-point correction offset latch request			0	Setting	—	—	○	—	—	
567(237H)	CH1	Sensor two-point correction gain latch request			0	Setting	—	—	○	—	—	
568(238H)	CH1	Sensor two-point correction offset value (measured value)			0	Setting	○	○	○	○	—	
569(239H)	CH1	Sensor two-point correction offset value (corrected value)			0	Setting	○	○	○	○	—	
570(23AH)	CH1	Sensor two-point correction gain value (measured value)			0	Setting	○	○	○	○	—	
571(23BH)	CH1	Sensor two-point correction gain value (corrected value)			0	Setting	○	○	○	○	—	
572(23CH)	CH1	Number of moving averaging setting			2	Setting	—	○	○	○	—	
573 to 599 (23DH to 257H)	—	System area			—	—	—	—	—	—	—	
600(258H)	CH2	Decimal point position			0(TC TRT) 1(TCRT)	Monitor	—	—	—	—	—	
601(259H)	CH2	Alert definition			0	Monitor	—	—	—	—	○	
602(25AH)	CH2	Temperature process value (PV)			0	Monitor	—	—	—	—	○	
603(25BH)	CH2	Manipulated value (MV)	Manipulated value for heating (MVh)	Manipulated value for heating (MVh) ^{*6}	System area	0	Monitor	—	—	—	—	○
604(25CH)	CH2	Temperature rise judgment flag		Temperature rise judgment flag ^{*6}	Temperature rise judgment flag	0	Monitor	—	—	—	—	○
605(25DH)	CH2	Transistor output flag	Heating transistor output flag	Heating transistor output flag ^{*6}	Open side transistor output flag	0	Monitor	—	—	—	—	○
606(25EH)	CH2	Set value (SV) monitor		Set value (SV) monitor ^{*6}	Set value (SV) monitor	0	Monitor	—	—	—	—	○
607(25FH)	CH2	Manipulated value (MV) for output with another analog module	Manipulated value for heating (MVh) for output with another analog module	Manipulated value for heating (MVh) for output with another analog module ^{*6}	System area	0	Monitor	—	—	—	—	○
608(260H)	CH2	System area	Manipulated value for cooling (MVc)	Manipulated value for cooling (MVc) ^{*6}	System area	0	Monitor	—	—	—	—	○
609(261H)	CH2	System area	Manipulated value for cooling (MVc) for output with another analog module	Manipulated value for cooling (MVc) for output with another analog module ^{*6}	System area	0	Monitor	—	—	—	—	○
610(262H)	CH2	System area	Cooling transistor output flag	Cooling transistor output flag ^{*6}	Close side transistor output flag	0	Monitor	—	—	—	—	○
611(263H)	CH2	Self-tuning flag	System area			0	Monitor	—	—	—	—	○

Address: Decimal (hexadecimal)	CH	Setting details				Default value	Data type	(1)	(2)	(3)	(4)	(5)
		Standard control	Heating- cooling control	Mix control	Position- proportional control							
612(264H)	CH2	Process value (PV) scaling value		Process value (PV) scaling value ^{*6}	Process value (PV) scaling value	0	Monitor	—	—	—	—	○
613(265H)	CH2	AT simultaneous temperature rise parameter calculation flag	System area			0	Monitor	—	—	—	—	○
614(266H)	CH2	Simultaneous temperature rise status	System area			0	Monitor	—	—	—	—	○
615(267H)	CH2	Feed forward control forced start status		Feed forward control forced start status ^{*6}	System area	0	Monitor	—	—	—	—	○
616(268H)	CH2	Feed forward value tuning flag		Feed forward value tuning flag ^{*6}	System area	0	Monitor	—	—	—	—	○
617(269H)	CH2	Feed forward control READY flag			System area	0	Monitor	—	—	—	—	○
618(26AH)	CH2	Feed forward control forced start READY flag			System area	0	Monitor	—	—	—	—	○
619(26BH)	CH2	Sensor two-point correction offset latch completion				0	Monitor	—	—	—	—	○
620(26CH)	CH2	Sensor two-point correction gain latch completion				0	Monitor	—	—	—	—	○
621 to 629 (26DH to 275H)	—	System area				—	—	—	—	—	—	—
630(276H)	CH2	Set value (SV) setting		Set value (SV) setting ^{*6}	Set value (SV) setting	0	Control	○	○	○	—	—
631(277H)	CH2	Proportional band (P) setting	Heating proportional band (Ph) setting	Heating proportional band (Ph) setting ^{*6}	Proportional band (P) setting	30	Control	○	○	○	—	—
632(278H)	CH2	Integral time (I) setting		Integral time (I) setting ^{*6}	Integral time (I) setting	240	Control	—	○	○	—	—
633(279H)	CH2	Derivative time (D) setting		Derivative time (D) setting ^{*6}	Derivative time (D) setting	60	Control	—	○	○	—	—
634(27AH)	CH2	Alert set value 1		Alert set value 1 ^{*6}	Alert set value 1	0	Control	○	○	○	—	—
635(27BH)	CH2	Alert set value 2		Alert set value 2 ^{*6}	Alert set value 2	0	Control	○	○	○	—	—
636(27CH)	CH2	Alert set value 3		Alert set value 3 ^{*6}	Alert set value 3	0	Control	○	○	○	—	—
637(27DH)	CH2	Alert set value 4		Alert set value 4 ^{*6}	Alert set value 4	0	Control	○	○	○	—	—
638(27EH)	CH2	Temperature process value (PV) for input with another analog module		Temperature process value (PV) for input with another analog module ^{*6}	Temperature process value (PV) for input with another analog module	0	Control	—	—	○	—	—
639(27FH)	CH2	System area	Cooling proportional band (Pc) setting	Cooling proportional band (Pc) setting ^{*6}	System area	30	Control	○	○	○	—	—
640(280H)	CH2	Memory's PID constants read command		Memory's PID constants read command ^{*6}	Memory's PID constants read command	0	Control	—	—	○	—	—
641(281H)	CH2	Feed forward value memory read command		Feed forward value memory read command ^{*6}	System area	0	Control	—	—	○	—	—
642 to 699 (282H to 2BBH)	—	System area				—	—	—	—	—	—	—
700(2BCH)	CH2	HOLD/CLEAR setting				0	Setting	—	○	—	○	—



Address: Decimal (hexadecimal)	CH	Setting details				Default value	Data type	(1)	(2)	(3)	(4)	(5)
		Standard control	Heating- cooling control	Mix control	Position- proportional control							
701(2BDH)	CH2	Input range				2(TCRT) 7(TCRT)	Setting	—	○	○	○	—
702(2BEH)	CH2	Unused channel setting		Unused channel setting ^{*6}	Unused channel setting	0	Setting	—	○	○	—	—
703(2BFH)	CH2	Stop mode setting		Stop mode setting ^{*6}	Stop mode setting	1	Setting	—	○	○	—	—
704(2C0H)	CH2	Control output cycle setting	Heating control output cycle setting	Heating control output cycle setting ^{*6}	System area	30 ^{*14} 300 ^{*15}	Setting	—	○	○	—	—
705(2C1H)	CH2	Control response parameter	Control response parameter	Control response parameter ^{*6}	Control response parameter	0	Setting	—	○	○	—	—
706(2C2H)	CH2	Temperature rise completion range setting		Temperature rise completion range setting ^{*6}	Temperature rise completion range setting	1	Setting	—	○	○	—	—
707(2C3H)	CH2	Temperature rise completion soak time setting		Temperature rise completion soak time setting ^{*6}	Temperature rise completion soak time setting	0	Setting	—	○	○	—	—
708(2C4H)	CH2	Upper limit output limiter	Heating upper limit output limiter	Heating upper limit output limiter ^{*6}	System area	1000	Setting	—	○	○	—	—
709(2C5H)	CH2	Lower limit output limiter	System area			0	Setting	—	○	○	—	—
710(2C6H)	CH2	Output variation amount limiter		Output variation amount limiter ^{*6}	System area	0	Setting	—	○	○	—	—
711(2C7H)	CH2	Upper limit setting limiter		Upper limit setting limiter ^{*6}	Upper limit setting limiter	1300(TCRT) 6000(TCRT)	Setting	○	○	○	—	—
712(2C8H)	CH2	Lower limit setting limiter		Lower limit setting limiter ^{*6}	Lower limit setting limiter	0(TCRT) -2000(TCRT)	Setting	○	○	○	—	—
713(2C9H)	CH2	Setting variation rate limiter/setting variation rate limiter (temperature rise) ^{*2}		Setting variation rate limiter/ setting variation rate limiter (temperature rise) ^{*2*6}	Setting variation rate limiter/ setting variation rate limiter (temperature rise) ^{*2}	0	Setting	—	○	○	—	—
714(2CAH)	CH2	Setting variation rate limiter (temperature drop) ^{*3}		Setting variation rate limiter (temperature drop) ^{*3*6}	Setting variation rate limiter (temperature drop) ^{*3}	0	Setting	—	○	○	—	—
715(2CBH)	CH2	Direct/reverse action setting	System area			Direct/reverse action setting	1	Setting	—	○	○	—
716(2CCH)	CH2	Adjustment sensitivity (dead band) setting		Adjustment sensitivity (dead band) setting ^{*6}	Adjustment sensitivity (dead band) setting	5	Setting	—	○	○	—	—
717(2CDH)	CH2	Manual reset amount setting		Manual reset amount setting ^{*6}	System area	0	Setting	—	○	○	—	—
718(2CEH)	CH2	AUTO/MAN mode shift		AUTO/MAN mode shift ^{*6}	System area	0	Setting	—	○	○	—	—
719(2CFH)	CH2	MAN output setting		MAN output setting ^{*6}	System area	0	Setting	—	○	○	—	—
720(2D0H)	CH2	System area			Temperature conversion setting ^{*7}	System area	0	Setting	—	○	○	—
721(2D1H)	CH2	System area	Cooling upper limit output limiter	Cooling upper limit output limiter ^{*6}	System area	1000	Setting	—	○	○	—	—
722(2D2H)	CH2	System area	Cooling control output cycle setting	Cooling control output cycle setting ^{*6}	System area	30 ^{*14} 300 ^{*15}	Setting	—	○	○	—	—

Address: Decimal (hexadecimal)	CH	Setting details				Default value	Data type	(1)	(2)	(3)	(4)	(5)
		Standard control	Heating- cooling control	Mix control	Position- proportional control							
723(2D3H)	CH2	System area	Cooling method setting	Cooling method setting ^{*6}	System area	0	Setting	—	○	○	○	—
724(2D4H)	CH2	System area	Overlap/dead band setting	Overlap/dead band setting ^{*6}	System area	0	Setting	—	○	○	—	—
725(2D5H)	CH2	Derivative action selection		Derivative action selection ^{*6}	System area	0	Setting	—	○	○	○	—
726(2D6H)	CH2	Setting variation rate limiter unit time setting		Setting variation rate limiter unit time setting ^{*6}	Setting variation rate limiter unit time setting	0	Setting	—	○	○	○	—
727(2D7H)	CH2	System area			Open/close output neutral band setting	20	Setting	—	○	○	○	—
728(2D8H)	CH2	System area			Control motor time	10	Setting	—	○	○	○	—
729(2D9H)	CH2	System area			Integration output limiter setting	1500	Setting	—	○	○	○	—
730(2DAH)	CH2	System area			Valve operation setting during CPU module STOP	0	Setting	—	○	○	○	—
731(2DBH)	CH2	Alert dead band setting		Alert dead band setting ^{*6}	Alert dead band setting	5	Setting	○	○	○	—	—
732(2DCH)	CH2	Number of alert delay		Number of alert delay ^{*6}	Number of alert delay	0	Setting	—	○	○	—	—
733(2DDH)	CH2	Alert 1 mode setting		Alert 1 mode setting ^{*6}	Alert 1 mode setting	0	Setting	—	○	○	○	—
734(2DEH)	CH2	Alert 2 mode setting		Alert 2 mode setting ^{*6}	Alert 2 mode setting	0	Setting	—	○	○	○	—
735(2DFH)	CH2	Alert 3 mode setting		Alert 3 mode setting ^{*6}	Alert 3 mode setting	0	Setting	—	○	○	○	—
736(2E0H)	CH2	Alert 4 mode setting		Alert 4 mode setting ^{*6}	Alert 4 mode setting	0	Setting	—	○	○	○	—
737(2E1H)	CH2	Loop disconnection detection judgment time	System area			480	Setting	—	○	○	—	—
738(2E2H)	CH2	Loop disconnection detection dead band	System area			0	Setting	○	○	○	—	—
739(2E3H)	CH2	Rate alarm alert output enable/disable setting				1	Setting	—	○	○	○	—
740(2E4H)	CH2	Rate alarm alert detection cycle				1	Setting	—	○	○	○	—
741(2E5H)	CH2	Rate alarm upper limit value				0	Setting	—	○	○	○	—
742(2E6H)	CH2	Rate alarm lower limit value				0	Setting	—	○	○	○	—
743(2E7H)	CH2	Auto tuning mode selection		Auto tuning mode selection ^{*6}	Auto tuning mode selection	0	Setting	—	○	○	—	—
744(2E8H)	CH2	Auto tuning error judgment time		Auto tuning error judgment time ^{*6}	Auto tuning error judgment time	120	Setting	—	○	○	—	—
745(2E9H)	CH2	During AT loop disconnection detection function enable/ disable	System area			0	Setting	—	○	○	—	—
746(2EAH)	CH2	AT bias		AT bias ^{*6}	AT bias	0	Setting	○	○	○	—	—

Address: Decimal (hexadecimal)	CH	Setting details				Default value	Data type	(1)	(2)	(3)	(4)	(5)
		Standard control	Heating- cooling control	Mix control	Position- proportional control							
747(2EBH)	CH2	Automatic backup setting after auto tuning of PID constants		Automatic backup setting after auto tuning of PID constants ^{*6}	Automatic backup setting after auto tuning of PID constants	0	Setting	—	—	○	—	—
748(2ECH)	CH2	Self-tuning setting	System area			0	Setting	—	○	○	—	—
749(2EDH)	CH2	Process value (PV) scaling function enable/disable setting		Process value (PV) scaling function enable/disable setting ^{*6}	Process value (PV) scaling function enable/disable setting	0	Setting	—	○	○	○	—
750(2EEH)	CH2	Process value (PV) scaling upper limit value		Process value (PV) scaling upper limit value ^{*6}	Process value (PV) scaling upper limit value	0	Setting	—	○	○	○	—
751(2EFH)	CH2	Process value (PV) scaling lower limit value		Process value (PV) scaling lower limit value ^{*6}	Process value (PV) scaling lower limit value	0	Setting	—	○	○	○	—
752(2F0H)	CH2	Peak current suppression control group setting	System area			0	Setting	—	○	○	○	—
753(2F1H)	CH2	Simultaneous temperature rise group setting	System area			0	Setting	—	○	○	○	—
754(2F2H)	CH2	Simultaneous temperature rise gradient data	System area			0	Setting	○	○	○	—	—
755(2F3H)	CH2	Simultaneous temperature rise dead time	System area			0	Setting	○	○	○	—	—
756(2F4H)	CH2	Simultaneous temperature rise AT mode selection	System area			0	Setting	—	○	○	—	—
757(2F5H)	CH2	Disturbance judgment position		Disturbance judgment position ^{*6}	System area	0	Setting	○	○	○	—	—
758(2F6H)	CH2	Set value return adjustment		Set value return adjustment ^{*6}	System area	0	Setting	—	○	○	—	—
759(2F7H)	CH2	Feed forward control forced starting signal		Feed forward control forced starting signal ^{*6}	System area	0	Setting	—	—	○	—	—
760(2F8H)	CH2	Feed forward value		Feed forward value ^{*6}	System area	0	Setting	—	○	○	—	—
761(2F9H)	CH2	Feed forward value tuning selection		Feed forward value tuning selection ^{*6}	System area	0	Setting	—	—	○	—	—
762(2FAH)	CH2	Overshoot suppression level setting		Overshoot suppression level setting ^{*6}	Overshoot suppression level setting	0	Setting	—	○	○	—	—
763(2FBH)	CH2	Primary delay digital filter setting				0	Setting	—	○	○	—	—
764(2FCH)	CH2	Sensor correction function selection				0	Setting	—	○	○	○	—
765(2FDH)	CH2	Sensor correction value setting				0	Setting	—	○	○	—	—
766(2FEH)	CH2	Sensor two-point correction offset latch request				0	Setting	—	—	○	—	—
767(2FFH)	CH2	Sensor two-point correction gain latch request				0	Setting	—	—	○	—	—
768(300H)	CH2	Sensor two-point correction offset value (measured value)				0	Setting	○	○	○	○	—
769(301H)	CH2	Sensor two-point correction offset value (corrected value)				0	Setting	○	○	○	○	—

Address: Decimal (hexadecimal)	CH	Setting details				Default value	Data type	(1)	(2)	(3)	(4)	(5)
		Standard control	Heating- cooling control	Mix control	Position- proportional control							
770(302H)	CH2	Sensor two-point correction gain value (measured value)				0	Setting	○	○	○	○	—
771(303H)	CH2	Sensor two-point correction gain value (corrected value)				0	Setting	○	○	○	○	—
772(304H)	CH2	Number of moving averaging setting				2	Setting	—	○	○	○	—
773 to 799 (305H to 31FH)	—	System area				—	—	—	—	—	—	—
800(320H)	CH3	Decimal point position				0(TCRT) 1(TCRT)	Monitor	—	—	—	—	—
801(321H)	CH3	Alert definition				0	Monitor	—	—	—	—	○
802(322H)	CH3	Temperature process value (PV)				0	Monitor	—	—	—	—	○
803(323H)	CH3	Manipulated value (MV)	Manipulated value for heating (MVh) ^{*4}	Manipulated value (MV)	System area	0	Monitor	—	—	—	—	○
804(324H)	CH3	Temperature rise judgment flag	Temperature rise judgment flag ^{*4}	Temperature rise judgment flag	Temperature rise judgment flag ^{*8}	0	Monitor	—	—	—	—	○
805(325H)	CH3	Transistor output flag	Heating transistor output flag ^{*4}	Transistor output flag	Open side transistor output flag ^{*8}	0	Monitor	—	—	—	—	○
806(326H)	CH3	Set value (SV) monitor	Set value (SV) monitor ^{*4}	Set value (SV) monitor	Set value (SV) monitor ^{*8}	0	Monitor	—	—	—	—	○
807(327H)	CH3	Manipulated value (MV) for output with another analog module	Manipulated value for heating (MVh) for output with another analog module ^{*4}	Manipulated value (MV) for output with another analog module	System area	0	Monitor	—	—	—	—	○
808(328H)	CH3	System area	Manipulated value for cooling (MVc) ^{*4}	System area	System area	0	Monitor	—	—	—	—	○
809(329H)	CH3	System area	Manipulated value for cooling (MVc) for output with another analog module ^{*4}	System area	System area	0	Monitor	—	—	—	—	○
810(32AH)	CH3	System area	Cooling transistor output flag ^{*4}	System area	Close side transistor output flag ^{*8}	0	Monitor	—	—	—	—	○
811(32BH)	CH3	Self-tuning flag	System area	Self-tuning flag	System area	0	Monitor	—	—	—	—	○
812(32CH)	CH3	Process value (PV) scaling value	Process value (PV) scaling value ^{*4}	Process value (PV) scaling value	Process value (PV) scaling value ^{*8}	0	Monitor	—	—	—	—	○
813(32DH)	CH3	AT simultaneous temperature rise parameter calculation flag	System area	AT simultaneous temperature rise parameter calculation flag	System area	0	Monitor	—	—	—	—	○
814(32EH)	CH3	Simultaneous temperature rise status	System area	Simultaneous temperature rise status	System area	0	Monitor	—	—	—	—	○
815(32FH)	CH3	Feed forward control forced start status	Feed forward control forced start status ^{*4}	Feed forward control forced start status	System area	0	Monitor	—	—	—	—	○
816(330H)	CH3	Feed forward value tuning flag	Feed forward value tuning flag ^{*4}	Feed forward value tuning flag	System area	0	Monitor	—	—	—	—	○
817(331H)	CH3	Feed forward control READY flag			System area	0	Monitor	—	—	—	—	○
818(332H)	CH3	Feed forward control forced start READY flag			System area	0	Monitor	—	—	—	—	○
819(333H)	CH3	Sensor two-point correction offset latch completion				0	Monitor	—	—	—	—	○
820(334H)	CH3	Sensor two-point correction gain latch completion				0	Monitor	—	—	—	—	○



Address: Decimal (hexadecimal)	CH	Setting details				Default value	Data type	(1)	(2)	(3)	(4)	(5)
		Standard control	Heating- cooling control	Mix control	Position- proportional control							
821 to 829 (335H to 33DH)	—	System area				—	—	—	—	—	—	—
830(33EH)	CH3	Set value (SV) setting	Set value (SV) setting ^{*4}	Set value (SV) setting	Set value (SV) setting ^{*8}	0	Control	○	○	○	—	—
831(33FH)	CH3	Proportional band (P) setting	Heating proportional band (Ph) setting ^{*4}	Proportional band (P) setting	Proportional band (P) setting ^{*8}	30	Control	○	○	○	—	—
832(340H)	CH3	Integral time (I) setting	Integral time (I) setting ^{*4}	Integral time (I) setting	Integral time (I) setting ^{*8}	240	Control	—	○	○	—	—
833(341H)	CH3	Derivative time (D) setting	Derivative time (D) setting ^{*4}	Derivative time (D) setting	Derivative time (D) setting ^{*8}	60	Control	—	○	○	—	—
834(342H)	CH3	Alert set value 1	Alert set value 1 ^{*4}	Alert set value 1	Alert set value 1 ^{*8}	0	Control	○	○	○	—	—
835(343H)	CH3	Alert set value 2	Alert set value 2 ^{*4}	Alert set value 2	Alert set value 2 ^{*8}	0	Control	○	○	○	—	—
836(344H)	CH3	Alert set value 3	Alert set value 3 ^{*4}	Alert set value 3	Alert set value 3 ^{*8}	0	Control	○	○	○	—	—
837(345H)	CH3	Alert set value 4	Alert set value 4 ^{*4}	Alert set value 4	Alert set value 4 ^{*8}	0	Control	○	○	○	—	—
838(346H)	CH3	Temperature process value (PV) for input with another analog module	Temperature process value (PV) for input with another analog module ^{*4}	Temperature process value (PV) for input with another analog module	Temperature process value (PV) for input with another analog module ^{*8}	0	Control	—	—	○	—	—
839(347H)	CH3	System area	Cooling proportional band (Pc) setting ^{*4}	System area	System area	30	Control	○	○	○	—	—
840(348H)	CH3	Memory's PID constants read command	Memory's PID constants read command ^{*4}	Memory's PID constants read command	Memory's PID constants read command ^{*8}	0	Control	—	—	○	—	—
841(349H)	CH3	Feed forward value memory read command	Feed forward value memory read command ^{*4}	Feed forward value memory read command	System area	0	Control	—	—	○	—	—
842 to 899 (34AH to 383H)	—	System area				—	—	—	—	—	—	—
900(384H)	CH3	HOLD/CLEAR setting				0	Setting	—	○	—	○	—
901(385H)	CH3	Input range				2(TCRT) 7(TCRT)	Setting	—	○	○	○	—
902(386H)	CH3	Unused channel setting	Unused channel setting ^{*4}	Unused channel setting	Unused channel setting ^{*8}	0	Setting	—	○	○	—	—
903(387H)	CH3	Stop mode setting	Stop mode setting ^{*4}	Stop mode setting	Stop mode setting ^{*8}	1	Setting	—	○	○	—	—
904(388H)	CH3	Control output cycle setting	Heating control output cycle setting ^{*4}	Control output cycle setting	System area	30 ^{*14} 300 ^{*15}	Setting	—	○	○	—	—
905(389H)	CH3	Control response parameter	Control response parameter ^{*4}	Control response parameter	Control response parameter ^{*8}	0	Setting	—	○	○	—	—
906(38AH)	CH3	Temperature rise completion range setting	Temperature rise completion range setting ^{*4}	Temperature rise completion range setting	Temperature rise completion range setting ^{*8}	1	Setting	—	○	○	—	—
907(38BH)	CH3	Temperature rise completion soak time setting	Temperature rise completion soak time setting ^{*4}	Temperature rise completion soak time setting	Temperature rise completion soak time setting ^{*8}	0	Setting	—	○	○	—	—

Address: Decimal (hexadecimal)	CH	Setting details				Default value	Data type	(1)	(2)	(3)	(4)	(5)
		Standard control	Heating- cooling control	Mix control	Position- proportional control							
908(38CH)	CH3	Upper limit output limiter	Heating upper limit output limiter ^{*4}	Upper limit output limiter	System area	1000	Setting	—	○	○	—	—
909(38DH)	CH3	Lower limit output limiter	System area	Lower limit output limiter	System area	0	Setting	—	○	○	—	—
910(38EH)	CH3	Output variation amount limiter	Output variation amount limiter ^{*4}	Output variation amount limiter	System area	0	Setting	—	○	○	—	—
911(38FH)	CH3	Upper limit setting limiter	Upper limit setting limiter ^{*4}	Upper limit setting limiter	Upper limit setting limiter ^{*8}	1300(TCRT) 6000(TCRT)	Setting	○	○	○	—	—
912(390H)	CH3	Lower limit setting limiter	Lower limit setting limiter ^{*4}	Lower limit setting limiter	Lower limit setting limiter ^{*8}	0(TCRT) -2000(TCRT)	Setting	○	○	○	—	—
913(391H)	CH3	Setting variation rate limiter/ setting variation rate limiter (temperature rise) ^{*2}	Setting variation rate limiter/ setting variation rate limiter (temperature rise) ^{*2*4}	Setting variation rate limiter/ setting variation rate limiter (temperature rise) ^{*2}	Setting variation rate limiter/ setting variation rate limiter (temperature rise) ^{*2*8}	0	Setting	—	○	○	—	—
914(392H)	CH3	Setting variation rate limiter (temperature drop) ^{*3}	Setting variation rate limiter (temperature drop) ^{*3*4}	Setting variation rate limiter (temperature drop) ^{*3}	Setting variation rate limiter (temperature drop) ^{*3*8}	0	Setting	—	○	○	—	—
915(393H)	CH3	Direct/reverse action setting	System area	Direct/reverse action setting	Direct/reverse action setting ^{*8}	1	Setting	—	○	○	—	—
916(394H)	CH3	Adjustment sensitivity (dead band) setting	Adjustment sensitivity (dead band) setting ^{*4}	Adjustment sensitivity (dead band) setting	Adjustment sensitivity (dead band) setting ^{*8}	5	Setting	—	○	○	—	—
917(395H)	CH3	Manual reset amount setting	Manual reset amount setting ^{*4}	Manual reset amount setting	System area	0	Setting	—	○	○	—	—
918(396H)	CH3	AUTO/MAN mode shift	AUTO/MAN mode shift ^{*4}	AUTO/MAN mode shift	System area	0	Setting	—	○	○	—	—
919(397H)	CH3	MAN output setting	MAN output setting ^{*4}	MAN output setting	System area	0	Setting	—	○	○	—	—
920(398H)	CH3	System area	Temperature conversion setting ^{*5}	System area	Temperature conversion setting ^{*9}	0	Setting	—	○	○	—	—
921(399H)	CH3	System area	Cooling upper limit output limiter ^{*4}	System area		1000	Setting	—	○	○	—	—
922(39AH)	CH3	System area	Cooling control output cycle setting ^{*4}	System area		30 ^{*14} 300 ^{*15}	Setting	—	○	○	—	—
923(39BH)	CH3	System area	Cooling method setting ^{*4}	System area		0	Setting	—	○	○	○	—
924(39CH)	CH3	System area	Overlap/dead band setting ^{*4}	System area		0	Setting	—	○	○	—	—
925(39DH)	CH3	Derivative action selection	Derivative action selection ^{*4}	Derivative action selection	System area	0	Setting	—	○	○	○	—
926(39EH)	CH3	Setting variation rate limiter unit time setting	Setting variation rate limiter unit time setting ^{*4}	Setting variation rate limiter unit time setting	Setting variation rate limiter unit time setting ^{*8}	0	Setting	—	○	○	○	—
927(39FH)	CH3	System area			Open/close output neutral band setting ^{*8}	20	Setting	—	○	○	○	—
928(3A0H)	CH3	System area			Control motor time ^{*8}	10	Setting	—	○	○	○	—
929(3A1H)	CH3	System area			Integration output limiter setting ^{*8}	1500	Setting	—	○	○	○	—

Address: Decimal (hexadecimal)	CH	Setting details				Default value	Data type	(1)	(2)	(3)	(4)	(5)	
		Standard control	Heating- cooling control	Mix control	Position- proportional control								
930(3A2H)	CH3	System area				Valve operation setting during CPU module STOP* ⁸	0	Setting	—	○	○	○	—
931(3A3H)	CH3	Alert dead band setting	Alert dead band setting* ⁴	Alert dead band setting	Alert dead band setting* ⁸	5	Setting	○	○	○	—	—	
932(3A4H)	CH3	Number of alert delay	Number of alert delay* ⁴	Number of alert delay	Number of alert delay* ⁸	0	Setting	—	○	○	—	—	
933(3A5H)	CH3	Alert 1 mode setting	Alert 1 mode setting* ⁴	Alert 1 mode setting	Alert 1 mode setting* ⁸	0	Setting	—	○	○	○	—	
934(3A6H)	CH3	Alert 2 mode setting	Alert 2 mode setting* ⁴	Alert 2 mode setting	Alert 2 mode setting* ⁸	0	Setting	—	○	○	○	—	
935(3A7H)	CH3	Alert 3 mode setting	Alert 3 mode setting* ⁴	Alert 3 mode setting	Alert 3 mode setting* ⁸	0	Setting	—	○	○	○	—	
936(3A8H)	CH3	Alert 4 mode setting	Alert 4 mode setting* ⁴	Alert 4 mode setting	Alert 4 mode setting* ⁸	0	Setting	—	○	○	○	—	
937(3A9H)	CH3	Loop disconnection detection judgment time	System area	Loop disconnection detection judgment time	System area	480	Setting	—	○	○	—	—	
938(3AAH)	CH3	Loop disconnection detection dead band	System area	Loop disconnection detection dead band	System area	0	Setting	○	○	○	—	—	
939(3ABH)	CH3	Rate alarm alert output enable/disable setting				1	Setting	—	○	○	○	—	
940(3ACH)	CH3	Rate alarm alert detection cycle				1	Setting	—	○	○	○	—	
941(3ADH)	CH3	Rate alarm upper limit value				0	Setting	—	○	○	○	—	
942(3AEH)	CH3	Rate alarm lower limit value				0	Setting	—	○	○	○	—	
943(3AFH)	CH3	Auto tuning mode selection	Auto tuning mode selection* ⁴	Auto tuning mode selection	Auto tuning mode selection* ⁸	0	Setting	—	○	○	—	—	
944(3B0H)	CH3	Auto tuning error judgment time	Auto tuning error judgment time* ⁴	Auto tuning error judgment time	Auto tuning error judgment time* ⁸	120	Setting	—	○	○	—	—	
945(3B1H)	CH3	During AT loop disconnection detection function enable/disable	System area	During AT loop disconnection detection function enable/disable	System area	0	Setting	—	○	○	—	—	
946(3B2H)	CH3	AT bias	AT bias* ⁴	AT bias	AT bias* ⁸	0	Setting	○	○	○	—	—	
947(3B3H)	CH3	Automatic backup setting after auto tuning of PID constants	Automatic backup setting after auto tuning of PID constants* ⁴	Automatic backup setting after auto tuning of PID constants	Automatic backup setting after auto tuning of PID constants* ⁸	0	Setting	—	—	○	—	—	
948(3B4H)	CH3	Self-tuning setting	System area	Self-tuning setting	System area	0	Setting	—	○	○	—	—	
949(3B5H)	CH3	Process value (PV) scaling function enable/disable setting	Process value (PV) scaling function enable/disable setting* ⁴	Process value (PV) scaling function enable/disable setting	Process value (PV) scaling function enable/disable setting* ⁸	0	Setting	—	○	○	○	—	
950(3B6H)	CH3	Process value (PV) scaling upper limit value	Process value (PV) scaling upper limit value* ⁴	Process value (PV) scaling upper limit value	Process value (PV) scaling upper limit value* ⁸	0	Setting	—	○	○	○	—	
951(3B7H)	CH3	Process value (PV) scaling lower limit value	Process value (PV) scaling lower limit value* ⁴	Process value (PV) scaling lower limit value	Process value (PV) scaling lower limit value* ⁸	0	Setting	—	○	○	○	—	

Address: Decimal (hexadecimal)	CH	Setting details				Default value	Data type	(1)	(2)	(3)	(4)	(5)	
		Standard control	Heating- cooling control	Mix control	Position- proportional control								
952(3B8H)	CH3	Peak current suppression control group setting	System area				0	Setting	—	○	○	○	—
953(3B9H)	CH3	Simultaneous temperature rise group setting	System area	Simultaneous temperature rise group setting	System area		0	Setting	—	○	○	○	—
954(3BAH)	CH3	Simultaneous temperature rise gradient data	System area	Simultaneous temperature rise gradient data	System area		0	Setting	○	○	○	—	—
955(3BBH)	CH3	Simultaneous temperature rise dead time	System area	Simultaneous temperature rise dead time	System area		0	Setting	○	○	○	—	—
956(3BCH)	CH3	Simultaneous temperature rise AT mode selection	System area	Simultaneous temperature rise AT mode selection	System area		0	Setting	—	○	○	—	—
957(3BDH)	CH3	Disturbance judgment position	Disturbance judgment position ^{*4}	Disturbance judgment position	System area		0	Setting	○	○	○	—	—
958(3BEH)	CH3	Set value return adjustment	Set value return adjustment ^{*4}	Set value return adjustment	System area		0	Setting	—	○	○	—	—
959(3BFH)	CH3	Feed forward control forced starting signal	Feed forward control forced starting signal ^{*4}	Feed forward control forced starting signal	System area		0	Setting	—	—	○	—	—
960(3C0H)	CH3	Feed forward value	Feed forward value ^{*4}	Feed forward value	System area		0	Setting	—	○	○	—	—
961(3C1H)	CH3	Feed forward value tuning selection	Feed forward value tuning selection ^{*4}	Feed forward value tuning selection	System area		0	Setting	—	—	○	—	—
962(3C2H)	CH3	Overshoot suppression level setting	Overshoot suppression level setting ^{*4}	Overshoot suppression level setting	Overshoot suppression level setting ^{*8}		0	Setting	—	○	○	—	—
963(3C3H)	CH3	Primary delay digital filter setting				0	Setting	—	○	○	—	—	
964(3C4H)	CH3	Sensor correction function selection				0	Setting	—	○	○	○	—	
965(3C5H)	CH3	Sensor correction value setting				0	Setting	—	○	○	—	—	
966(3C6H)	CH3	Sensor two-point correction offset latch request				0	Setting	—	—	○	—	—	
967(3C7H)	CH3	Sensor two-point correction gain latch request				0	Setting	—	—	○	—	—	
968(3C8H)	CH3	Sensor two-point correction offset value (measured value)				0	Setting	○	○	○	○	—	
969(3C9H)	CH3	Sensor two-point correction offset value (corrected value)				0	Setting	○	○	○	○	—	
970(3CAH)	CH3	Sensor two-point correction gain value (measured value)				0	Setting	○	○	○	○	—	
971(3CBH)	CH3	Sensor two-point correction gain value (corrected value)				0	Setting	○	○	○	○	—	
972(3CCH)	CH3	Number of moving averaging setting				2	Setting	—	○	○	○	—	
973 to 999 (3CDH to 3E7H)	—	System area				—	—	—	—	—	—	—	
1000(3E8H)	CH4	Decimal point position				0(TCRT) 1(TCRT)	Monitor	—	—	—	—	—	
1001(3E9H)	CH4	Alert definition				0	Monitor	—	—	—	—	○	
1002(3EAH)	CH4	Temperature process value (PV)				0	Monitor	—	—	—	—	○	
1003(3EBH)	CH4	Manipulated value (MV)	Manipulated value for heating (MVh) ^{*4}	Manipulated value (MV)	System area		0	Monitor	—	—	—	—	○
1004(3ECH)	CH4	Temperature rise judgment flag	Temperature rise judgment flag ^{*4}	Temperature rise judgment flag	Temperature rise judgment flag ^{*8}		0	Monitor	—	—	—	—	○
1005(3EDH)	CH4	Transistor output flag	Heating transistor output flag ^{*4}	Transistor output flag	Open side transistor output flag ^{*8}		0	Monitor	—	—	—	—	○

Address: Decimal (hexadecimal)	CH	Setting details				Default value	Data type	(1)	(2)	(3)	(4)	(5)
		Standard control	Heating- cooling control	Mix control	Position- proportional control							
1006(3EEH)	CH4	Set value (SV) monitor	Set value (SV) monitor ^{*4}	Set value (SV) monitor	Set value (SV) monitor ^{*8}	0	Monitor	—	—	—	—	○
1007(3EFH)	CH4	Manipulated value (MV) for output with another analog module	Manipulated value for heating (MVh) for output with another analog module ^{*4}	Manipulated value (MV) for output with another analog module	System area	0	Monitor	—	—	—	—	○
1008(3F0H)	CH4	System area	Manipulated value for cooling (MVC) ^{*4}	System area	System area	0	Monitor	—	—	—	—	○
1009(3F1H)	CH4	System area	Manipulated value for cooling (MVC) for output with another analog module ^{*4}	System area	System area	0	Monitor	—	—	—	—	○
1010(3F2H)	CH4	System area	Cooling transistor output flag ^{*4}	System area	Close side transistor output flag ^{*8}	0	Monitor	—	—	—	—	○
1011(3F3H)	CH4	Self-tuning flag	System area	Self-tuning flag	System area	0	Monitor	—	—	—	—	○
1012(3F4H)	CH4	Process value (PV) scaling value	Process value (PV) scaling value ^{*4}	Process value (PV) scaling value	Process value (PV) scaling value ^{*8}	0	Monitor	—	—	—	—	○
1013(3F5H)	CH4	AT simultaneous temperature rise parameter calculation flag	System area	AT simultaneous temperature rise parameter calculation flag	System area	0	Monitor	—	—	—	—	○
1014(3F6H)	CH4	Simultaneous temperature rise status	System area	Simultaneous temperature rise status	System area	0	Monitor	—	—	—	—	○
1015(3F7H)	CH4	Feed forward control forced start status	Feed forward control forced start status ^{*4}	Feed forward control forced start status	System area	0	Monitor	—	—	—	—	○
1016(3F8H)	CH4	Feed forward value tuning flag	Feed forward value tuning flag ^{*4}	Feed forward value tuning flag	System area	0	Monitor	—	—	—	—	○
1017(3F9H)	CH4	Feed forward control READY flag			System area	0	Monitor	—	—	—	—	○
1018(3FAH)	CH4	Feed forward control forced start READY flag			System area	0	Monitor	—	—	—	—	○
1019(3FBH)	CH4	Sensor two-point correction offset latch completion				0	Monitor	—	—	—	—	○
1020(3FCH)	CH4	Sensor two-point correction gain latch completion				0	Monitor	—	—	—	—	○
1021 to 1029 (3FDH to 405H)	—	System area				—	—	—	—	—	—	—
1030(406H)	CH4	Set value (SV) setting	Set value (SV) setting ^{*4}	Set value (SV) setting	Set value (SV) setting ^{*8}	0	Control	○	○	○	—	—
1031(407H)	CH4	Proportional band (P) setting	Heating proportional band (Ph) setting ^{*4}	Proportional band (P) setting	Proportional band (P) setting ^{*8}	30	Control	○	○	○	—	—
1032(408H)	CH4	Integral time (I) setting	Integral time (I) setting ^{*4}	Integral time (I) setting	Integral time (I) setting ^{*8}	240	Control	—	○	○	—	—
1033(409H)	CH4	Derivative time (D) setting	Derivative time (D) setting ^{*4}	Derivative time (D) setting	Derivative time (D) setting ^{*8}	60	Control	—	○	○	—	—
1034(40AH)	CH4	Alert set value 1	Alert set value 1 ^{*4}	Alert set value 1	Alert set value 1 ^{*8}	0	Control	○	○	○	—	—
1035(40BH)	CH4	Alert set value 2	Alert set value 2 ^{*4}	Alert set value 2	Alert set value 2 ^{*8}	0	Control	○	○	○	—	—
1036(40CH)	CH4	Alert set value 3	Alert set value 3 ^{*4}	Alert set value 3	Alert set value 3 ^{*8}	0	Control	○	○	○	—	—

Address: Decimal (hexadecimal)	CH	Setting details				Default value	Data type	(1)	(2)	(3)	(4)	(5)
		Standard control	Heating- cooling control	Mix control	Position- proportional control							
1037(40DH)	CH4	Alert set value 4	Alert set value 4 ^{*4}	Alert set value 4	Alert set value 4 ^{*8}	0	Control	○	○	○	—	—
1038(40EH)	CH4	Temperature process value (PV) for input with another analog module	Temperature process value (PV) for input with another analog module ^{*4}	Temperature process value (PV) for input with another analog module	Temperature process value (PV) for input with another analog module ^{*8}	0	Control	—	—	○	—	—
1039(40FH)	CH4	System area	Cooling proportional band (Pc) setting ^{*4}	System area	System area	30	Control	○	○	○	—	—
1040(410H)	CH4	Memory's PID constants read command	Memory's PID constants read command ^{*4}	Memory's PID constants read command	Memory's PID constants read command ^{*8}	0	Control	—	—	○	—	—
1041(411H)	CH4	Feed forward value memory read command	Feed forward value memory read command ^{*4}	Feed forward value memory read command	System area	0	Control	—	—	○	—	—
1042 to 1099 (412H to 44BH)	—	System area				—	—	—	—	—	—	—
1100(44CH)	CH4	HOLD/CLEAR setting				0	Setting	—	○	—	○	—
1101(44DH)	CH4	Input range				2(TCRT) 7(TCRT)	Setting	—	○	○	○	—
1102(44EH)	CH4	Unused channel setting	Unused channel setting ^{*4}	Unused channel setting	Unused channel setting ^{*8}	0	Setting	—	○	○	—	—
1103(44FH)	CH4	Stop mode setting	Stop mode setting ^{*4}	Stop mode setting	Stop mode setting ^{*8}	1	Setting	—	○	○	—	—
1104(450H)	CH4	Control output cycle setting	Heating control output cycle setting ^{*4}	Control output cycle setting	System area	30 ^{*14} 300 ^{*15}	Setting	—	○	○	—	—
1105(451H)	CH4	Control response parameter	Control response parameter ^{*4}	Control response parameter	Control response parameter ^{*8}	0	Setting	—	○	○	—	—
1106(452H)	CH4	Temperature rise completion range setting	Temperature rise completion range setting ^{*4}	Temperature rise completion range setting	Temperature rise completion range setting ^{*8}	1	Setting	—	○	○	—	—
1107(453H)	CH4	Temperature rise completion soak time setting	Temperature rise completion soak time setting ^{*4}	Temperature rise completion soak time setting	Temperature rise completion soak time setting ^{*8}	0	Setting	—	○	○	—	—
1108(454H)	CH4	Upper limit output limiter	Heating upper limit output limiter ^{*4}	Upper limit output limiter	System area	1000	Setting	—	○	○	—	—
1109(455H)	CH4	Lower limit output limiter	System area	Lower limit output limiter	System area	0	Setting	—	○	○	—	—
1110(456H)	CH4	Output variation amount limiter	Output variation amount limiter ^{*4}	Output variation amount limiter	System area	0	Setting	—	○	○	—	—
1111(457H)	CH4	Upper limit setting limiter	Upper limit setting limiter ^{*4}	Upper limit setting limiter	Upper limit setting limiter ^{*8}	1300(TCRT) 6000(TCRT)	Setting	○	○	○	—	—
1112(458H)	CH4	Lower limit setting limiter	Lower limit setting limiter ^{*4}	Lower limit setting limiter	Lower limit setting limiter ^{*8}	0(TCRT) -2000(TCRT)	Setting	○	○	○	—	—
1113(459H)	CH4	Setting variation rate limiter/ setting variation rate limiter (temperature rise) ^{*2}	Setting variation rate limiter/ setting variation rate limiter (temperature rise) ^{*2*4}	Setting variation rate limiter/ setting variation rate limiter (temperature rise) ^{*2}	Setting variation rate limiter/ setting variation rate limiter (temperature rise) ^{*2*8}	0	Setting	—	○	○	—	—



Address: Decimal (hexadecimal)	CH	Setting details				Default value	Data type	(1)	(2)	(3)	(4)	(5)
		Standard control	Heating- cooling control	Mix control	Position- proportional control							
1114(45AH)	CH4	Setting variation rate limiter (temperature drop) ^{*3}	Setting variation rate limiter (temperature drop) ^{*3,4}	Setting variation rate limiter (temperature drop) ^{*3}	Setting variation rate limiter (temperature drop) ^{*3,8}	0	Setting	—	○	○	—	—
1115(45BH)	CH4	Direct/reverse action setting	System area	Direct/reverse action setting	Direct/reverse action setting ^{*8}	1	Setting	—	○	○	—	—
1116(45CH)	CH4	Adjustment sensitivity (dead band) setting	Adjustment sensitivity (dead band) setting ^{*4}	Adjustment sensitivity (dead band) setting	Adjustment sensitivity (dead band) setting ^{*8}	5	Setting	—	○	○	—	—
1117(45DH)	CH4	Manual reset amount setting	Manual reset amount setting ^{*4}	Manual reset amount setting	System area	0	Setting	—	○	○	—	—
1118(45EH)	CH4	AUTO/MAN mode shift	AUTO/MAN mode shift ^{*4}	AUTO/MAN mode shift	System area	0	Setting	—	○	○	—	—
1119(45FH)	CH4	MAN output setting	MAN output setting ^{*4}	MAN output setting	System area	0	Setting	—	○	○	—	—
1120(460H)	CH4	System area	Temperature conversion setting ^{*5}	System area	Temperature conversion setting ^{*9}	0	Setting	—	○	○	—	—
1121(461H)	CH4	System area	Cooling upper limit output limiter ^{*4}	System area		1000	Setting	—	○	○	—	—
1122(462H)	CH4	System area	Cooling control output cycle setting ^{*4}	System area		30 ^{*14} 300 ^{*15}	Setting	—	○	○	—	—
1123(463H)	CH4	System area	Cooling method setting ^{*4}	System area		0	Setting	—	○	○	○	—
1124(464H)	CH4	System area	Overlap/dead band setting ^{*4}	System area		0	Setting	—	○	○	—	—
1125(465H)	CH4	Derivative action selection	Derivative action selection ^{*4}	Derivative action selection	System area	0	Setting	—	○	○	○	—
1126(466H)	CH4	Setting variation rate limiter unit time setting	Setting variation rate limiter unit time setting ^{*4}	Setting variation rate limiter unit time setting	Setting variation rate limiter unit time setting ^{*8}	0	Setting	—	○	○	○	—
1127(467H)	CH4	System area			Open/close output neutral band setting ^{*8}	20	Setting	—	○	○	○	—
1128(468H)	CH4	System area			Control motor time ^{*8}	10	Setting	—	○	○	○	—
1129(469H)	CH4	System area			Integration output limiter setting ^{*8}	1500	Setting	—	○	○	○	—
1130(46AH)	CH4	System area			Valve operation setting during CPU module STOP ^{*8}	0	Setting	—	○	○	○	—
1131(46BH)	CH4	Alert dead band setting	Alert dead band setting ^{*4}	Alert dead band setting	Alert dead band setting ^{*8}	5	Setting	○	○	○	—	—
1132(46CH)	CH4	Number of alert delay	Number of alert delay ^{*4}	Number of alert delay	Number of alert delay ^{*8}	0	Setting	—	○	○	—	—
1133(46DH)	CH4	Alert 1 mode setting	Alert 1 mode setting ^{*4}	Alert 1 mode setting	Alert 1 mode setting ^{*8}	0	Setting	—	○	○	○	—
1134(46EH)	CH4	Alert 2 mode setting	Alert 2 mode setting ^{*4}	Alert 2 mode setting	Alert 2 mode setting ^{*8}	0	Setting	—	○	○	○	—
1135(46FH)	CH4	Alert 3 mode setting	Alert 3 mode setting ^{*4}	Alert 3 mode setting	Alert 3 mode setting ^{*8}	0	Setting	—	○	○	○	—
1136(470H)	CH4	Alert 4 mode setting	Alert 4 mode setting ^{*4}	Alert 4 mode setting	Alert 4 mode setting ^{*8}	0	Setting	—	○	○	○	—

Address: Decimal (hexadecimal)	CH	Setting details				Default value	Data type	(1)	(2)	(3)	(4)	(5)
		Standard control	Heating- cooling control	Mix control	Position- proportional control							
1137(471H)	CH4	Loop disconnection detection judgment time	System area	Loop disconnection detection judgment time	System area	480	Setting	—	○	○	—	—
1138(472H)	CH4	Loop disconnection detection dead band	System area	Loop disconnection detection dead band	System area	0	Setting	○	○	○	—	—
1139(473H)	CH4	Rate alarm alert output enable/disable setting				1	Setting	—	○	○	○	—
1140(474H)	CH4	Rate alarm alert detection cycle				1	Setting	—	○	○	○	—
1141(475H)	CH4	Rate alarm upper limit value				0	Setting	—	○	○	○	—
1142(476H)	CH4	Rate alarm lower limit value				0	Setting	—	○	○	○	—
1143(477H)	CH4	Auto tuning mode selection	Auto tuning mode selection ^{*4}	Auto tuning mode selection	Auto tuning mode selection ^{*8}	0	Setting	—	○	○	—	—
1144(478H)	CH4	Auto tuning error judgment time	Auto tuning error judgment time ^{*4}	Auto tuning error judgment time	Auto tuning error judgment time ^{*8}	120	Setting	—	○	○	—	—
1145(479H)	CH4	During AT loop disconnection detection function enable/disable	System area	During AT loop disconnection detection function enable/disable	System area	0	Setting	—	○	○	—	—
1146(47AH)	CH4	AT bias	AT bias ^{*4}	AT bias	AT bias ^{*8}	0	Setting	○	○	○	—	—
1147(47BH)	CH4	Automatic backup setting after auto tuning of PID constants	Automatic backup setting after auto tuning of PID constants ^{*4}	Automatic backup setting after auto tuning of PID constants	Automatic backup setting after auto tuning of PID constants ^{*8}	0	Setting	—	—	○	—	—
1148(47CH)	CH4	Self-tuning setting	System area	Self-tuning setting	System area	0	Setting	—	○	○	—	—
1149(47DH)	CH4	Process value (PV) scaling function enable/disable setting	Process value (PV) scaling function enable/disable setting ^{*4}	Process value (PV) scaling function enable/disable setting	Process value (PV) scaling function enable/disable setting ^{*8}	0	Setting	—	○	○	○	—
1150(47EH)	CH4	Process value (PV) scaling upper limit value	Process value (PV) scaling upper limit value ^{*4}	Process value (PV) scaling upper limit value	Process value (PV) scaling upper limit value ^{*8}	0	Setting	—	○	○	○	—
1151(47FH)	CH4	Process value (PV) scaling lower limit value	Process value (PV) scaling lower limit value ^{*4}	Process value (PV) scaling lower limit value	Process value (PV) scaling lower limit value ^{*8}	0	Setting	—	○	○	○	—
1152(480H)	CH4	Peak current suppression control group setting	System area	System area	System area	0	Setting	—	○	○	○	—
1153(481H)	CH4	Simultaneous temperature rise group setting	System area	Simultaneous temperature rise group setting	System area	0	Setting	—	○	○	○	—
1154(482H)	CH4	Simultaneous temperature rise gradient data	System area	Simultaneous temperature rise gradient data	System area	0	Setting	○	○	○	—	—
1155(483H)	CH4	Simultaneous temperature rise dead time	System area	Simultaneous temperature rise dead time	System area	0	Setting	○	○	○	—	—
1156(484H)	CH4	Simultaneous temperature rise AT mode selection	System area	Simultaneous temperature rise AT mode selection	System area	0	Setting	—	○	○	—	—

Address: Decimal (hexadecimal)	CH	Setting details				Default value	Data type	(1)	(2)	(3)	(4)	(5)
		Standard control	Heating- cooling control	Mix control	Position- proportional control							
1157(485H)	CH4	Disturbance judgment position	Disturbance judgment position* ⁴	Disturbance judgment position	System area	0	Setting	○	○	○	—	—
1158(486H)	CH4	Set value return adjustment	Set value return adjustment* ⁴	Set value return adjustment	System area	0	Setting	—	○	○	—	—
1159(487H)	CH4	Feed forward control forced starting signal	Feed forward control forced starting signal* ⁴	Feed forward control forced starting signal	System area	0	Setting	—	—	○	—	—
1160(488H)	CH4	Feed forward value	Feed forward value* ⁴	Feed forward value	System area	0	Setting	—	○	○	—	—
1161(489H)	CH4	Feed forward value tuning selection	Feed forward value tuning selection* ⁴	Feed forward value tuning selection	System area	0	Setting	—	—	○	—	—
1162(48AH)	CH4	Overshoot suppression level setting	Overshoot suppression level setting* ⁴	Overshoot suppression level setting	Overshoot suppression level setting* ⁸	0	Setting	—	○	○	—	—
1163(48BH)	CH4	Primary delay digital filter setting				0	Setting	—	○	○	—	—
1164(48CH)	CH4	Sensor correction function selection				0	Setting	—	○	○	○	—
1165(48DH)	CH4	Sensor correction value setting				0	Setting	—	○	○	—	—
1166(48EH)	CH4	Sensor two-point correction offset latch request				0	Setting	—	—	○	—	—
1167(48FH)	CH4	Sensor two-point correction gain latch request				0	Setting	—	—	○	—	—
1168(490H)	CH4	Sensor two-point correction offset value (measured value)				0	Setting	○	○	○	○	—
1169(491H)	CH4	Sensor two-point correction offset value (corrected value)				0	Setting	○	○	○	○	—
1170(492H)	CH4	Sensor two-point correction gain value (measured value)				0	Setting	○	○	○	○	—
1171(493H)	CH4	Sensor two-point correction gain value (corrected value)				0	Setting	○	○	○	○	—
1172(494H)	CH4	Number of moving averaging setting				2	Setting	—	○	○	○	—
1173 to 1999 (495H to 7CFH)	—	System area				—	—	—	—	—	—	—
2000(7D0H)	All	Heater disconnection/output off-time current error detection delay count* ¹³			System area	3	Setting	—	○	○	—	—
2001(7D1H)	All	Heater disconnection correction function selection* ¹³			System area	0	Setting	—	○	○	—	—
2002(7D2H)	All	CT monitor method selection* ¹³			System area	0	Setting	—	○	○	—	—
2003(7D3H)	—	System area				—	—	—	—	—	—	—
2004(7D4H)	CH1	Heater disconnection alert setting* ¹³			System area	0	Setting	—	○	○	—	—
2005(7D5H)	CH1	Heater disconnection judgment mode* ¹³			System area	0	Setting	—	○	○	○	—
2006(7D6H)	—	System area				—	—	—	—	—	—	—
2007(7D7H)	CH2	Heater disconnection alert setting* ¹³		System area		0	Setting	—	○	○	—	—
2008(7D8H)	CH2	Heater disconnection judgment mode* ¹³		System area		0	Setting	—	○	○	○	—
2009(7D9H)	—	System area				—	—	—	—	—	—	—
2010(7DAH)	CH3	Heater disconnection alert setting* ¹³	System area	Heater disconnection alert setting* ¹³	System area	0	Setting	—	○	○	—	—
2011(7DBH)	CH3	Heater disconnection judgment mode* ¹³	System area	Heater disconnection judgment mode* ¹³	System area	0	Setting	—	○	○	○	—
2012(7DCH)	—	System area				—	—	—	—	—	—	—
2013(7DDH)	CH4	Heater disconnection alert setting* ¹³	System area	Heater disconnection alert setting* ¹³	System area	0	Setting	—	○	○	—	—
2014(7DEH)	CH4	Heater disconnection judgment mode* ¹³	System area	Heater disconnection judgment mode* ¹³	System area	0	Setting	—	○	○	○	—

Address: Decimal (hexadecimal)	CH	Setting details				Default value	Data type	(1)	(2)	(3)	(4)	(5)
		Standard control	Heating- cooling control	Mix control	Position- proportional control							
2015 to 2029 (7DFH to 7EDH)	—	System area				—	—	—	—	—	—	—
2030(7EEH)	CT1	Heater current process value* ¹³		System area	0	Monitor	—	—	—	—	○	
2031(7EFH)	CT2	Heater current process value* ¹³		System area	0	Monitor	—	—	—	—	○	
2032(7F0H)	CT3	Heater current process value* ¹³		System area	0	Monitor	—	—	—	—	○	
2033(7F1H)	CT4	Heater current process value* ¹³		System area	0	Monitor	—	—	—	—	○	
2034(7F2H)	CT5	Heater current process value* ¹³		System area	0	Monitor	—	—	—	—	○	
2035(7F3H)	CT6	Heater current process value* ¹³		System area	0	Monitor	—	—	—	—	○	
2036(7F4H)	CT7	Heater current process value* ¹³		System area	0	Monitor	—	—	—	—	○	
2037(7F5H)	CT8	Heater current process value* ¹³		System area	0	Monitor	—	—	—	—	○	
2038(7F6H)	CT1	CT input channel assignment setting* ¹³		System area	0	Setting	—	○	○	—	—	
2039(7F7H)	CT2	CT input channel assignment setting* ¹³		System area	0	Setting	—	○	○	—	—	
2040(7F8H)	CT3	CT input channel assignment setting* ¹³		System area	0	Setting	—	○	○	—	—	
2041(7F9H)	CT4	CT input channel assignment setting* ¹³		System area	0	Setting	—	○	○	—	—	
2042(7FAH)	CT5	CT input channel assignment setting* ¹³		System area	0	Setting	—	○	○	—	—	
2043(7FBH)	CT6	CT input channel assignment setting* ¹³		System area	0	Setting	—	○	○	—	—	
2044(7FCH)	CT7	CT input channel assignment setting* ¹³		System area	0	Setting	—	○	○	—	—	
2045(7FDH)	CT8	CT input channel assignment setting* ¹³		System area	0	Setting	—	○	○	—	—	
2046(7FEH)	CT1	CT selection* ¹³		System area	0	Setting	—	○	○	○	—	
2047(7FFH)	CT2	CT selection* ¹³		System area	0	Setting	—	○	○	○	—	
2048(800H)	CT3	CT selection* ¹³		System area	0	Setting	—	○	○	○	—	
2049(801H)	CT4	CT selection* ¹³		System area	0	Setting	—	○	○	○	—	
2050(802H)	CT5	CT selection* ¹³		System area	0	Setting	—	○	○	○	—	
2051(803H)	CT6	CT selection* ¹³		System area	0	Setting	—	○	○	○	—	
2052(804H)	CT7	CT selection* ¹³		System area	0	Setting	—	○	○	○	—	
2053(805H)	CT8	CT selection* ¹³		System area	0	Setting	—	○	○	○	—	
2054(806H)	CT1	Reference heater current value* ¹³		System area	0	Setting	—	○	○	—	—	
2055(807H)	CT2	Reference heater current value* ¹³		System area	0	Setting	—	○	○	—	—	
2056(808H)	CT3	Reference heater current value* ¹³		System area	0	Setting	—	○	○	—	—	
2057(809H)	CT4	Reference heater current value* ¹³		System area	0	Setting	—	○	○	—	—	
2058(80AH)	CT5	Reference heater current value* ¹³		System area	0	Setting	—	○	○	—	—	
2059(80BH)	CT6	Reference heater current value* ¹³		System area	0	Setting	—	○	○	—	—	
2060(80CH)	CT7	Reference heater current value* ¹³		System area	0	Setting	—	○	○	—	—	
2061(80DH)	CT8	Reference heater current value* ¹³		System area	0	Setting	—	○	○	—	—	
2062(80EH)	CT1	CT ratio setting* ¹³		System area	800	Setting	—	○	○	—	—	
2063(80FH)	CT2	CT ratio setting* ¹³		System area	800	Setting	—	○	○	—	—	
2064(810H)	CT3	CT ratio setting* ¹³		System area	800	Setting	—	○	○	—	—	
2065(811H)	CT4	CT ratio setting* ¹³		System area	800	Setting	—	○	○	—	—	
2066(812H)	CT5	CT ratio setting* ¹³		System area	800	Setting	—	○	○	—	—	
2067(813H)	CT6	CT ratio setting* ¹³		System area	800	Setting	—	○	○	—	—	
2068(814H)	CT7	CT ratio setting* ¹³		System area	800	Setting	—	○	○	—	—	
2069(815H)	CT8	CT ratio setting* ¹³		System area	800	Setting	—	○	○	—	—	
2070 to 2099 (816H to 833H)	—	System area				—	—	—	—	—	—	
2100(834H)	All	Inter-module peak current suppression function state monitor	System area		0	Monitor	—	—	—	—	○	

Address: Decimal (hexadecimal)	CH	Setting details				Default value	Data type	(1)	(2)	(3)	(4)	(5)
		Standard control	Heating- cooling control	Mix control	Position- proportional control							
2101(835H)	All	Inter-module peak current suppression function enable/disable monitor	System area			0	Monitor	—	—	—	—	—
2102(836H)	All	Inter-module peak current suppression function master/slave selection monitor	System area			0	Monitor	—	—	—	—	—
2103(837H)	All	Number of slave modules with inter-module peak current suppression function enabled ^{*12}	System area			0	Monitor	—	—	—	—	—
2104 to 2166 (838H to 876H)	All	Start I/O of slave module with inter-module peak current suppression function enabled ^{*12}	System area			0	Monitor	—	—	—	—	—
2167 to 2169 (877H to 879H)	—	System area				—	—	—	—	—	—	—
2170(87AH)	All	Inter-module simultaneous temperature rise function state monitor	System area	Inter-module simultaneous temperature rise function state monitor	System area	0	Monitor	—	—	—	—	○
2171(87BH)	All	Inter-module simultaneous temperature rise function enable/disable monitor	System area	Inter-module simultaneous temperature rise function enable/disable monitor	System area	0	Monitor	—	—	—	—	—
2172(87CH)	All	Inter-module simultaneous temperature rise function master/slave selection monitor	System area	Inter-module simultaneous temperature rise function master/slave selection monitor	System area	0	Monitor	—	—	—	—	—
2173(87DH)	All	Number of slave modules with inter-module simultaneous temperature rise function enabled ^{*11}	System area	Number of slave modules with inter-module simultaneous temperature rise function enabled	System area	0	Monitor	—	—	—	—	—
2174 to 2236 (87EH to 8BCH)	All	Start I/O of slave module with inter-module simultaneous temperature rise function enabled ^{*11}	System area	Start I/O of slave module with inter-module simultaneous temperature rise function enabled ^{*11}	System area	0	Monitor	—	—	—	—	—
2237 to 3599 (8BDH to E0FH)	—	System area				—	—	—	—	—	—	—
3600 to 3759 (E10H to EAFH)	All	Error history				0	Monitor	—	—	—	—	—
3760 to 3919 (EB0H to F4FH)	All	Alarm history				0	Monitor	—	—	—	—	—

Address: Decimal (hexadecimal)	CH	Setting details				Default value	Data type	(1)	(2)	(3)	(4)	(5)
		Standard control	Heating- cooling control	Mix control	Position- proportional control							
3920 to 4095 (F50H to FFFH)	—	System area				—	—	—	—	—	—	—

- *1 Enabled only when the R60TCTRT2TT2 or R60TCTRT2TT2BW is used.
- *2 This setting differs depending on whether 'Setting variation rate limiter setting selection' (Un\G303) is set to Individually set at temperature rise/temperature drop (1).
- *3 Enabled only when 'Setting variation rate limiter setting selection' (Un\G303) has been set to Individually set at temperature rise/temperature drop (1).
- *4 Enabled only when 'Control mode selection' (Un\G300) has been set to Heating-cooling control (expanded mode) (2). When Heating-cooling control (normal mode) (2) is set, this area becomes a system area.
- *5 Enabled only when 'Control mode selection' (Un\G300) has been set to Heating-cooling control (normal mode) (1). When Heating-cooling control (expanded mode) (1) is set, this area becomes a system area.
- *6 Enabled only when 'Control mode selection' (Un\G300) has been set to Mix control (expanded mode) (4). When Mix control (normal mode) (3) is set, this area becomes a system area.
- *7 Enabled only when 'Control mode selection' (Un\G300) has been set to Mix control (normal mode) (3). When Mix control (expanded mode) (4) is set, this area becomes a system area.
- *8 Enabled only when 'Control mode selection' (Un\G300) has been set to Position-proportional control (expanded mode) (6). When Position-proportional control (normal mode) (5) is set, this area becomes a system area.
- *9 Enabled only when 'Control mode selection' (Un\G300) has been set to Position-proportional control (normal mode) (5). When Position-proportional control (expanded mode) (6) is set, this area becomes a system area.
- *10 [n] in this table indicates an interrupt setting value. (n = 1 to 16)
- *11 This value is displayed only in the master module of the inter-module simultaneous temperature rise function. When multiple master modules have been set, 0 is stored in this area.
- *12 This value is displayed only in the master module of the inter-module peak current suppression function. When multiple master modules have been set, 0 is stored in this area.
- *13 Enabled only when the R60TCTRT2TT2BW or R60TCRT4BW is used.
- *14 When the control output cycle unit selection setting is 1s cycle
- *15 When the control output cycle unit selection setting is 0.1s cycle

In the Q compatible mode

The following table describes the items (1) to (5) in the list of buffer memory addresses.

No.	Item
(1)	Automatic setting target
(2)	Target saved in the non-volatile memory
(3)	Default setting registration command
(4)	Setting change command
(5)	Auto refresh

■Un\G0 to Un\G3176

Address: Decimal (hexadecimal)	CH	Setting details				Default value	Data type	(1)	(2)	(3)	(4)	(5)
		Standard control	Heating- cooling control	Mix control	Position- proportional control							
0(0H)	All	Latest error code				0	Monitor	—	—	—	—	○
1(1H)	CH1	Decimal point position				0(TCRT) 1(TCRT)	Monitor	—	—	—	—	—
2(2H)	CH2	Decimal point position				0(TCRT) 1(TCRT)	Monitor	—	—	—	—	—
3(3H)	CH3	Decimal point position				0(TCRT) 1(TCRT)	Monitor	—	—	—	—	—
4(4H)	CH4	Decimal point position				0(TCRT) 1(TCRT)	Monitor	—	—	—	—	—
5(5H)	CH1	Alert definition				0	Monitor	—	—	—	—	○
6(6H)	CH2	Alert definition				0	Monitor	—	—	—	—	○
7(7H)	CH3	Alert definition				0	Monitor	—	—	—	—	○
8(8H)	CH4	Alert definition				0	Monitor	—	—	—	—	○
9(9H)	CH1	Temperature process value (PV)				0	Monitor	—	—	—	—	○
10(AH)	CH2	Temperature process value (PV)				0	Monitor	—	—	—	—	○
11(BH)	CH3	Temperature process value (PV)				0	Monitor	—	—	—	—	○
12(CH)	CH4	Temperature process value (PV)				0	Monitor	—	—	—	—	○
13(DH)	CH1	Manipulated value (MV)	Manipulated value for heating (MVh)		System area	0	Monitor	—	—	—	—	○
14(EH)	CH2	Manipulated value (MV)	Manipulated value for heating (MVh)	Manipulated value for heating (MVh) ^{*3}	System area	0	Monitor	—	—	—	—	○
15(FH)	CH3	Manipulated value (MV)	Manipulated value for heating (MVh) ^{*1}	Manipulated value (MV)	System area	0	Monitor	—	—	—	—	○
16(10H)	CH4	Manipulated value (MV)	Manipulated value for heating (MVh) ^{*1}	Manipulated value (MV)	System area	0	Monitor	—	—	—	—	○
17(11H)	CH1	Temperature rise judgment flag				0	Monitor	—	—	—	—	○
18(12H)	CH2	Temperature rise judgment flag				0	Monitor	—	—	—	—	○
19(13H)	CH3	Temperature rise judgment flag	Temperature rise judgment flag ^{*1}	Temperature rise judgment flag	Temperature rise judgment flag ^{*5}	0	Monitor	—	—	—	—	○
20(14H)	CH4	Temperature rise judgment flag	Temperature rise judgment flag ^{*1}	Temperature rise judgment flag	Temperature rise judgment flag ^{*5}	0	Monitor	—	—	—	—	○
21(15H)	CH1	Transistor output flag	Heating transistor output flag	Heating transistor output flag	Open side transistor output flag	0	Monitor	—	—	—	—	○
22(16H)	CH2	Transistor output flag	Heating transistor output flag	Heating transistor output flag ^{*3}	Open side transistor output flag	0	Monitor	—	—	—	—	○

A

Address: Decimal (hexadecimal)	CH	Setting details				Default value	Data type	(1)	(2)	(3)	(4)	(5)
		Standard control	Heating- cooling control	Mix control	Position- proportional control							
23(17H)	CH3	Transistor output flag	Heating transistor output flag ^{*1}	Transistor output flag	Open side transistor output flag ^{*5}	0	Monitor	—	—	—	—	○
24(18H)	CH4	Transistor output flag	Heating transistor output flag ^{*1}	Transistor output flag	Open side transistor output flag ^{*5}	0	Monitor	—	—	—	—	○
25(19H)	CH1	Set value (SV) monitor				0	Monitor	—	—	—	—	○
26(1AH)	CH2	Set value (SV) monitor		Set value (SV) monitor ^{*3}	Set value (SV) monitor	0	Monitor	—	—	—	—	○
27(1BH)	CH3	Set value (SV) monitor	Set value (SV) monitor ^{*1}	Set value (SV) monitor	Set value (SV) monitor ^{*5}	0	Monitor	—	—	—	—	○
28(1CH)	CH4	Set value (SV) monitor	Set value (SV) monitor ^{*1}	Set value (SV) monitor	Set value (SV) monitor	0	Monitor	—	—	—	—	○
29(1DH)	All	Cold junction temperature process value ^{*12}				0	Monitor	—	—	—	—	—
30(1EH)	All	MAN mode shift completion flag			System area	0	Monitor	—	—	—	—	—
31(1FH)	All	Memory's PID constants read/write completion flag				0	Monitor	—	—	—	—	—
32(20H)	CH1	Input range				2(TCRT) 7(TCRT)	Setting	—	○	○	○	—
33(21H)	CH1	Stop mode setting				1	Setting	—	○	○	—	—
34(22H)	CH1	Set value (SV) setting				0	Setting	○	○	○	—	—
35(23H)	CH1	Proportional band (P) setting	Heating proportional band (Ph) setting	Heating proportional band (Ph) setting	Proportional band (P) setting	30	Setting	—	○	○	—	—
36(24H)	CH1	Integral time (I) setting				240	Setting	—	○	○	—	—
37(25H)	CH1	Derivative time (D) setting				60	Setting	—	○	○	—	—
38(26H)	CH1	Alert set value 1				0	Setting	○	○	○	—	—
39(27H)	CH1	Alert set value 2				0	Setting	○	○	○	—	—
40(28H)	CH1	Alert set value 3				0	Setting	○	○	○	—	—
41(29H)	CH1	Alert set value 4				0	Setting	○	○	○	—	—
42(2AH)	CH1	Upper limit output limiter	Heating upper limit output limiter		System area	1000	Setting	—	○	○	—	—
43(2BH)	CH1	Lower limit output limiter	System area			0	Setting	—	○	○	—	—
44(2CH)	CH1	Output variation amount limiter			System area	0	Setting	—	○	○	—	—
45(2DH)	CH1	Sensor correction value setting				0	Setting	—	○	○	—	—
46(2EH)	CH1	Adjustment sensitivity (dead band) setting				5	Setting	—	○	○	—	—
47(2FH)	CH1	Control output cycle setting	Heating control output cycle setting		System area	30 ^{*15} 300 ^{*16}	Setting	—	○	○	—	—
48(30H)	CH1	Primary delay digital filter setting				0	Setting	—	○	○	—	—
49(31H)	CH1	Control response parameter				0	Setting	—	○	○	—	—
50(32H)	CH1	AUTO/MAN mode shift			System area	0	Setting	—	○	○	—	—
51(33H)	CH1	MAN output setting			System area	0	Setting	—	○	○	—	—
52(34H)	CH1	Setting variation rate limiter/setting variation rate limiter (temperature rise) ^{*10}				0	Setting	—	○	○	—	—
53(35H)	CH1	AT bias				0	Setting	○	○	○	—	—
54(36H)	CH1	Direct/reverse action setting	System area		Direct/reverse action setting	1	Setting	—	○	○	—	—
55(37H)	CH1	Upper limit setting limiter				1300(TCRT) 6000(TCRT)	Setting	○	○	○	—	—
56(38H)	CH1	Lower limit setting limiter				0(TCRT) -2000(TCRT)	Setting	○	○	○	—	—
57(39H)	—	System area				—	—	—	—	—	—	—
58(3AH)	CH1	Heater disconnection alert setting ^{*11}			System area	0	Setting	—	○	○	—	—

Address: Decimal (hexadecimal)	CH	Setting details				Default value	Data type	(1)	(2)	(3)	(4)	(5)
		Standard control	Heating- cooling control	Mix control	Position- proportional control							
59(3BH)	CH1	Loop disconnection detection judgment time	System area			480	Setting	—	○	○	—	—
60(3CH)	CH1	Loop disconnection detection dead band	System area			0	Setting	○	○	○	—	—
61(3DH)	CH1	Unused channel setting				0	Setting	—	○	○	—	—
62(3EH)	CH1	Memory's PID constants read command				0	Setting	—	—	○	—	—
63(3FH)	CH1	Automatic backup setting after auto tuning of PID constants				0	Setting	—	—	○	—	—
64(40H)	CH2	Input range				2(TCRT) 7(TCRT)	Setting	—	○	○	○	—
65(41H)	CH2	Stop mode setting		Stop mode setting ^{*3}	Stop mode setting	1	Setting	—	○	○	—	—
66(42H)	CH2	Set value (SV) setting		Set value (SV) setting ^{*3}	Set value (SV) setting	0	Setting	○	○	○	—	—
67(43H)	CH2	Proportional band (P) setting	Heating proportional band (Ph) setting	Heating proportional band (Ph) setting ^{*3}	Proportional band (P) setting	30	Setting	—	○	○	—	—
68(44H)	CH2	Integral time (I) setting		Integral time (I) setting ^{*3}	Integral time (I) setting	240	Setting	—	○	○	—	—
69(45H)	CH2	Derivative time (D) setting		Derivative time (D) setting ^{*3}	Derivative time (D) setting	60	Setting	—	○	○	—	—
70(46H)	CH2	Alert set value 1		Alert set value 1 ^{*3}	Alert set value 1	0	Setting	○	○	○	—	—
71(47H)	CH2	Alert set value 2		Alert set value 2 ^{*3}	Alert set value 2	0	Setting	○	○	○	—	—
72(48H)	CH2	Alert set value 3		Alert set value 3 ^{*3}	Alert set value 3	0	Setting	○	○	○	—	—
73(49H)	CH2	Alert set value 4		Alert set value 4 ^{*3}	Alert set value 4	0	Setting	○	○	○	—	—
74(4AH)	CH2	Upper limit output limiter	Heating upper limit output limiter	Heating upper limit output limiter ^{*3}	System area	1000	Setting	—	○	○	—	—
75(4BH)	CH2	Lower limit output limiter	System area			0	Setting	—	○	○	—	—
76(4CH)	CH2	Output variation amount limiter		Output variation amount limiter ^{*3}	System area	0	Setting	—	○	○	—	—
77(4DH)	CH2	Sensor correction value setting				0	Setting	—	○	○	—	—
78(4EH)	CH2	Adjustment sensitivity (dead band) setting		Adjustment sensitivity (dead band) setting ^{*3}	Adjustment sensitivity (dead band) setting	5	Setting	—	○	○	—	—
79(4FH)	CH2	Control output cycle setting	Heating control output cycle setting	Heating control output cycle setting ^{*3}	System area	30 ^{*15} 300 ^{*16}	Setting	—	○	○	—	—
80(50H)	CH2	Primary delay digital filter setting				0	Setting	—	○	○	—	—
81(51H)	CH2	Control response parameter		Control response parameter ^{*3}	Control response parameter	0	Setting	—	○	○	—	—
82(52H)	CH2	AUTO/MAN mode shift		AUTO/MAN mode shift ^{*3}	System area	0	Setting	—	○	○	—	—
83(53H)	CH2	MAN output setting		MAN output setting ^{*3}	System area	0	Setting	—	○	○	—	—

Address: Decimal (hexadecimal)	CH	Setting details				Default value	Data type	(1)	(2)	(3)	(4)	(5)	
		Standard control	Heating- cooling control	Mix control	Position- proportional control								
84(54H)	CH2	Setting variation rate limiter/setting variation rate limiter (temperature rise) ^{*10}		Setting variation rate limiter/setting variation rate limiter (temperature rise) ^{*3*10}	Setting variation rate limiter/setting variation rate limiter (temperature rise) ^{*10}	0	Setting	—	○	○	—	—	
85(55H)	CH2	AT bias		AT bias ^{*3}	AT bias	0	Setting	○	○	○	—	—	
86(56H)	CH2	Direct/reverse action setting	System area			Direct/reverse action setting	1	Setting	—	○	○	—	—
87(57H)	CH2	Upper limit setting limiter		Upper limit setting limiter ^{*3}	Upper limit setting limiter	1300(TCRT) 6000(TCRT)	Setting	○	○	○	—	—	
88(58H)	CH2	Lower limit setting limiter		Lower limit setting limiter ^{*3}	Lower limit setting limiter	0(TCRT) -2000(TCRT)	Setting	○	○	○	—	—	
89(59H)	—	System area				—	—	—	—	—	—	—	
90(5AH)	CH2	Heater disconnection alert setting ^{*11}		System area		0	Setting	—	○	○	—	—	
91(5BH)	CH2	Loop disconnection detection judgment time	System area			480	Setting	—	○	○	—	—	
92(5CH)	CH2	Loop disconnection detection dead band	System area			0	Setting	○	○	○	—	—	
93(5DH)	CH2	Unused channel setting		Unused channel setting ^{*3}	Unused channel setting	0	Setting	—	○	○	—	—	
94(5EH)	CH2	Memory's PID constants read command		Memory's PID constants read command ^{*3}	Memory's PID constants read command	0	Setting	—	—	○	—	—	
95(5FH)	CH2	Automatic backup setting after auto tuning of PID constants		Automatic backup setting after auto tuning of PID constants ^{*3}	Automatic backup setting after auto tuning of PID constants	0	Setting	—	—	○	—	—	
96(60H)	CH3	Input range				2(TCRT) 7(TCRT)	Setting	—	○	○	○	—	
97(61H)	CH3	Stop mode setting	Stop mode setting ^{*1}	Stop mode setting	Stop mode setting ^{*5}	1	Setting	—	○	○	—	—	
98(62H)	CH3	Set value (SV) setting	Set value (SV) setting ^{*1}	Set value (SV) setting	Set value (SV) setting ^{*5}	0	Setting	○	○	○	—	—	
99(63H)	CH3	Proportional band (P) setting	Heating proportional band (Ph) setting ^{*1}	Proportional band (P) setting	Proportional band (P) setting ^{*5}	30	Setting	—	○	○	—	—	
100(64H)	CH3	Integral time (I) setting	Integral time (I) setting ^{*1}	Integral time (I) setting	Integral time (I) setting ^{*5}	240	Setting	—	○	○	—	—	
101(65H)	CH3	Derivative time (D) setting	Derivative time (D) setting ^{*1}	Derivative time (D) setting	Derivative time (D) setting ^{*5}	60	Setting	—	○	○	—	—	
102(66H)	CH3	Alert set value 1	Alert set value 1 ^{*1}	Alert set value 1	Alert set value 1 ^{*5}	0	Setting	○	○	○	—	—	
103(67H)	CH3	Alert set value 2	Alert set value 2 ^{*1}	Alert set value 2	Alert set value 2 ^{*5}	0	Setting	○	○	○	—	—	
104(68H)	CH3	Alert set value 3	Alert set value 3 ^{*1}	Alert set value 3	Alert set value 3 ^{*5}	0	Setting	○	○	○	—	—	
105(69H)	CH3	Alert set value 4	Alert set value 4 ^{*1}	Alert set value 4	Alert set value 4 ^{*5}	0	Setting	○	○	○	—	—	
106(6AH)	CH3	Upper limit output limiter	Heating upper limit output limiter ^{*1}	Upper limit output limiter	System area	1000	Setting	—	○	○	—	—	

Address: Decimal (hexadecimal)	CH	Setting details				Default value	Data type	(1)	(2)	(3)	(4)	(5)
		Standard control	Heating- cooling control	Mix control	Position- proportional control							
107(6BH)	CH3	Lower limit output limiter	System area	Lower limit output limiter	System area	0	Setting	—	○	○	—	—
108(6CH)	CH3	Output variation amount limiter	Output variation amount limiter ^{*1}	Output variation amount limiter	System area	0	Setting	—	○	○	—	—
109(6DH)	CH3	Sensor correction value setting				0	Setting	—	○	○	—	—
110(6EH)	CH3	Adjustment sensitivity (dead band) setting	Adjustment sensitivity (dead band) setting ^{*1}	Adjustment sensitivity (dead band) setting	Adjustment sensitivity (dead band) setting ^{*5}	5	Setting	—	○	○	—	—
111(6FH)	CH3	Control output cycle setting	Heating control output cycle setting ^{*1}	Control output cycle setting	System area	30 ^{*15} 300 ^{*16}	Setting	—	○	○	—	—
112(70H)	CH3	Primary delay digital filter setting				0	Setting	—	○	○	—	—
113(71H)	CH3	Control response parameter	Control response parameter ^{*1}	Control response parameter	Control response parameter ^{*5}	0	Setting	—	○	○	—	—
114(72H)	CH3	AUTO/MAN mode shift	AUTO/MAN mode shift ^{*1}	AUTO/MAN mode shift	System area	0	Setting	—	○	○	—	—
115(73H)	CH3	MAN output setting	MAN output setting ^{*1}	MAN output setting	System area	0	Setting	—	○	○	—	—
116(74H)	CH3	Setting variation rate limiter/ setting variation rate limiter (temperature rise) ^{*10}	Setting variation rate limiter/ setting variation rate limiter (temperature rise) ^{*1*10}	Setting variation rate limiter/ setting variation rate limiter (temperature rise) ^{*10}	Setting variation rate limiter/ setting variation rate limiter (temperature rise) ^{*5*10}	0	Setting	—	○	○	—	—
117(75H)	CH3	AT bias	AT bias ^{*1}	AT bias	AT bias ^{*5}	0	Setting	○	○	○	—	—
118(76H)	CH3	Direct/reverse action setting	System area	Direct/reverse action setting	Direct/reverse action setting ^{*5}	1	Setting	—	○	○	—	—
119(77H)	CH3	Upper limit setting limiter	Upper limit setting limiter ^{*1}	Upper limit setting limiter	Upper limit setting limiter ^{*5}	1300(TCRT) 6000(TCRT)	Setting	○	○	○	—	—
120(78H)	CH3	Lower limit setting limiter	Lower limit setting limiter ^{*1}	Lower limit setting limiter	Lower limit setting limiter ^{*5}	0(TCRT) -2000(TCRT)	Setting	○	○	○	—	—
121(79H)	—	System area				—	—	—	—	—	—	—
122(7AH)	CH3	Heater disconnection alert setting ^{*11}	System area	Heater disconnection alert setting ^{*11}	System area	0	Setting	—	○	○	—	—
123(7BH)	CH3	Loop disconnection detection judgment time	System area	Loop disconnection detection judgment time	System area	480	Setting	—	○	○	—	—
124(7CH)	CH3	Loop disconnection detection dead band	System area	Loop disconnection detection dead band	System area	0	Setting	○	○	○	—	—
125(7DH)	CH3	Unused channel setting	Unused channel setting ^{*1}	Unused channel setting	Unused channel setting ^{*5}	0	Setting	—	○	○	—	—
126(7EH)	CH3	Memory's PID constants read command	Memory's PID constants read command ^{*1}	Memory's PID constants read command	Memory's PID constants read command ^{*5}	0	Setting	—	—	○	—	—
127(7FH)	CH3	Automatic backup setting after auto tuning of PID constants	Automatic backup setting after auto tuning of PID constants ^{*1}	Automatic backup setting after auto tuning of PID constants	Automatic backup setting after auto tuning of PID constants ^{*5}	0	Setting	—	—	○	—	—
128(80H)	CH4	Input range				2(TCRT) 7(TCRT)	Setting	—	○	○	○	—
129(81H)	CH4	Stop mode setting	Stop mode setting ^{*1}	Stop mode setting	Stop mode setting ^{*5}	1	Setting	—	○	○	—	—

Address: Decimal (hexadecimal)	CH	Setting details				Default value	Data type	(1)	(2)	(3)	(4)	(5)
		Standard control	Heating- cooling control	Mix control	Position- proportional control							
130(82H)	CH4	Set value (SV) setting	Set value (SV) setting ^{*1}	Set value (SV) setting	Set value (SV) setting ^{*5}	0	Setting	<input type="radio"/>	<input type="radio"/>	<input type="radio"/>	<input type="checkbox"/>	<input type="checkbox"/>
131(83H)	CH4	Proportional band (P) setting	Heating proportional band (Ph) setting ^{*1}	Proportional band (P) setting	Proportional band (P) setting ^{*5}	30	Setting	<input type="checkbox"/>	<input type="radio"/>	<input type="radio"/>	<input type="checkbox"/>	<input type="checkbox"/>
132(84H)	CH4	Integral time (I) setting	Integral time (I) setting ^{*1}	Integral time (I) setting	Integral time (I) setting ^{*5}	240	Setting	<input type="checkbox"/>	<input type="radio"/>	<input type="radio"/>	<input type="checkbox"/>	<input type="checkbox"/>
133(85H)	CH4	Derivative time (D) setting	Derivative time (D) setting ^{*1}	Derivative time (D) setting	Derivative time (D) setting ^{*5}	60	Setting	<input type="checkbox"/>	<input type="radio"/>	<input type="radio"/>	<input type="checkbox"/>	<input type="checkbox"/>
134(86H)	CH4	Alert set value 1	Alert set value 1 ^{*1}	Alert set value 1	Alert set value 1 ^{*5}	0	Setting	<input type="radio"/>	<input type="radio"/>	<input type="radio"/>	<input type="checkbox"/>	<input type="checkbox"/>
135(87H)	CH4	Alert set value 2	Alert set value 2 ^{*1}	Alert set value 2	Alert set value 2 ^{*5}	0	Setting	<input type="radio"/>	<input type="radio"/>	<input type="radio"/>	<input type="checkbox"/>	<input type="checkbox"/>
136(88H)	CH4	Alert set value 3	Alert set value 3 ^{*1}	Alert set value 3	Alert set value 3 ^{*5}	0	Setting	<input type="radio"/>	<input type="radio"/>	<input type="radio"/>	<input type="checkbox"/>	<input type="checkbox"/>
137(89H)	CH4	Alert set value 4	Alert set value 4 ^{*1}	Alert set value 4	Alert set value 4 ^{*5}	0	Setting	<input type="radio"/>	<input type="radio"/>	<input type="radio"/>	<input type="checkbox"/>	<input type="checkbox"/>
138(8AH)	CH4	Upper limit output limiter	Heating upper limit output limiter ^{*1}	Upper limit output limiter	System area	1000	Setting	<input type="checkbox"/>	<input type="radio"/>	<input type="radio"/>	<input type="checkbox"/>	<input type="checkbox"/>
139(8BH)	CH4	Lower limit output limiter	System area	Lower limit output limiter	System area	0	Setting	<input type="checkbox"/>	<input type="radio"/>	<input type="radio"/>	<input type="checkbox"/>	<input type="checkbox"/>
140(8CH)	CH4	Output variation amount limiter	Output variation amount limiter ^{*1}	Output variation amount limiter	System area	0	Setting	<input type="checkbox"/>	<input type="radio"/>	<input type="radio"/>	<input type="checkbox"/>	<input type="checkbox"/>
141(8DH)	CH4	Sensor correction value setting				0	Setting	<input type="checkbox"/>	<input type="radio"/>	<input type="radio"/>	<input type="checkbox"/>	<input type="checkbox"/>
142(8EH)	CH4	Adjustment sensitivity (dead band) setting	Adjustment sensitivity (dead band) setting ^{*1}	Adjustment sensitivity (dead band) setting	Adjustment sensitivity (dead band) setting ^{*5}	5	Setting	<input type="checkbox"/>	<input type="radio"/>	<input type="radio"/>	<input type="checkbox"/>	<input type="checkbox"/>
143(8FH)	CH4	Control output cycle setting	Heating control output cycle setting ^{*1}	Control output cycle setting	System area	30 ^{*15} 300 ^{*16}	Setting	<input type="checkbox"/>	<input type="radio"/>	<input type="radio"/>	<input type="checkbox"/>	<input type="checkbox"/>
144(90H)	CH4	Primary delay digital filter setting				0	Setting	<input type="checkbox"/>	<input type="radio"/>	<input type="radio"/>	<input type="checkbox"/>	<input type="checkbox"/>
145(91H)	CH4	Control response parameter	Control response parameter ^{*1}	Control response parameter	Control response parameter ^{*5}	0	Setting	<input type="checkbox"/>	<input type="radio"/>	<input type="radio"/>	<input type="checkbox"/>	<input type="checkbox"/>
146(92H)	CH4	AUTO/MAN mode shift	AUTO/MAN mode shift ^{*1}	AUTO/MAN mode shift	System area	0	Setting	<input type="checkbox"/>	<input type="radio"/>	<input type="radio"/>	<input type="checkbox"/>	<input type="checkbox"/>
147(93H)	CH4	MAN output setting	MAN output setting ^{*1}	MAN output setting	System area	0	Setting	<input type="checkbox"/>	<input type="radio"/>	<input type="radio"/>	<input type="checkbox"/>	<input type="checkbox"/>
148(94H)	CH4	Setting variation rate limiter/ setting variation rate limiter (temperature rise) ^{*10}	Setting variation rate limiter/ setting variation rate limiter (temperature rise) ^{*1*10}	Setting variation rate limiter/ setting variation rate limiter (temperature rise) ^{*10}	Setting variation rate limiter/ setting variation rate limiter (temperature rise) ^{*5*10}	0	Setting	<input type="checkbox"/>	<input type="radio"/>	<input type="radio"/>	<input type="checkbox"/>	<input type="checkbox"/>
149(95H)	CH4	AT bias	AT bias ^{*1}	AT bias	AT bias ^{*5}	0	Setting	<input type="radio"/>	<input type="radio"/>	<input type="radio"/>	<input type="checkbox"/>	<input type="checkbox"/>
150(96H)	CH4	Direct/reverse action setting	System area	Direct/reverse action setting	Direct/reverse action setting ^{*5}	1	Setting	<input type="checkbox"/>	<input type="radio"/>	<input type="radio"/>	<input type="checkbox"/>	<input type="checkbox"/>
151(97H)	CH4	Upper limit setting limiter	Upper limit setting limiter ^{*1}	Upper limit setting limiter	Upper limit setting limiter ^{*5}	1300(TCRT) 6000(TCRT)	Setting	<input type="radio"/>	<input type="radio"/>	<input type="radio"/>	<input type="checkbox"/>	<input type="checkbox"/>
152(98H)	CH4	Lower limit setting limiter	Lower limit setting limiter ^{*1}	Lower limit setting limiter	Lower limit setting limiter ^{*5}	0(TCRT) -2000(TCRT)	Setting	<input type="radio"/>	<input type="radio"/>	<input type="radio"/>	<input type="checkbox"/>	<input type="checkbox"/>
153(99H)	—	System area				—	—	<input type="checkbox"/>	<input type="checkbox"/>	<input type="checkbox"/>	<input type="checkbox"/>	<input type="checkbox"/>
154(9AH)	CH4	Heater disconnection alert setting ^{*11}	System area	Heater disconnection alert setting ^{*11}	System area	0	Setting	<input type="checkbox"/>	<input type="radio"/>	<input type="radio"/>	<input type="checkbox"/>	<input type="checkbox"/>

Address: Decimal (hexadecimal)	CH	Setting details				Default value	Data type	(1)	(2)	(3)	(4)	(5)
		Standard control	Heating- cooling control	Mix control	Position- proportional control							
155(9BH)	CH4	Loop disconnection detection judgment time	System area	Loop disconnection detection judgment time	System area	480	Setting	—	○	○	—	—
156(9CH)	CH4	Loop disconnection detection dead band	System area	Loop disconnection detection dead band	System area	0	Setting	○	○	○	—	—
157(9DH)	CH4	Unused channel setting	Unused channel setting ^{*1}	Unused channel setting	Unused channel setting ^{*5}	0	Setting	—	○	○	—	—
158(9EH)	CH4	Memory's PID constants read command	Memory's PID constants read command ^{*1}	Memory's PID constants read command	Memory's PID constants read command ^{*5}	0	Setting	—	—	○	—	—
159(9FH)	CH4	Automatic backup setting after auto tuning of PID constants	Automatic backup setting after auto tuning of PID constants ^{*1}	Automatic backup setting after auto tuning of PID constants	Automatic backup setting after auto tuning of PID constants ^{*5}	0	Setting	—	—	○	—	—
160 to 163 (A0H to A3H)	—	System area				—	—	—	—	—	—	—
164(A4H)	All	Alert dead band setting				5	Setting	—	○	○	—	—
165(A5H)	All	Number of alert delay				0	Setting	—	○	○	—	—
166(A6H)	All	Heater disconnection/output off-time current error detection delay count ^{*11}			System area	3	Setting	—	○	○	—	—
167(A7H)	All	Temperature rise completion range setting				1	Setting	—	○	○	—	—
168(A8H)	All	Temperature rise completion soak time setting				0	Setting	—	○	○	—	—
169(A9H)	All	PID continuation flag				0	Setting	—	○	○	—	—
170(AAH)	All	Heater disconnection correction function selection ^{*11}			System area	0	Setting	—	○	○	—	—
171 to 174 (ABH to AEH)	—	System area				—	—	—	—	—	—	—
175(AFH)	All	Transistor output monitor ON delay time setting				0	Setting	—	○	○	—	—
176(B0H)	All	CT monitor method selection ^{*11}			System area	0	Setting	—	○	○	—	—
177(B1H)	CH1	Manipulated value (MV) for output with another analog module	Manipulated value for heating (MVh) for output with another analog module		System area	0	Monitor	—	—	—	—	○
178(B2H)	CH2	Manipulated value (MV) for output with another analog module	Manipulated value for heating (MVh) for output with another analog module	Manipulated value for heating (MVh) for output with another analog module ^{*3}	System area	0	Monitor	—	—	—	—	○
179(B3H)	CH3	Manipulated value (MV) for output with another analog module	Manipulated value for heating (MVh) for output with another analog module ^{*1}	Manipulated value (MV) for output with another analog module	System area	0	Monitor	—	—	—	—	○
180(B4H)	CH4	Manipulated value (MV) for output with another analog module	Manipulated value for heating (MVh) for output with another analog module ^{*1}	Manipulated value (MV) for output with another analog module	System area	0	Monitor	—	—	—	—	○
181(B5H)	All	Manipulated value resolution change for output with another analog module			System area	0	Setting	—	○	○	○	—
182(B6H)	All	Cold junction temperature compensation selection ^{*12}				0	Setting	—	○	○	—	—
183(B7H)	All	Control mode selection monitor				0	Monitor	—	—	—	—	—

Address: Decimal (hexadecimal)	CH	Setting details				Default value	Data type	(1)	(2)	(3)	(4)	(5)
		Standard control	Heating- cooling control	Mix control	Position- proportional control							
184(B8H)	CH1	Auto tuning mode selection				0	Setting	—	○	○	—	—
185(B9H)	CH2	Auto tuning mode selection		Auto tuning mode selection ^{*3}	Auto tuning mode selection	0	Setting	—	○	○	—	—
186(BAH)	CH3	Auto tuning mode selection	Auto tuning mode selection ^{*1}	Auto tuning mode selection	Auto tuning mode selection ^{*5}	0	Setting	—	○	○	—	—
187(BBH)	CH4	Auto tuning mode selection	Auto tuning mode selection ^{*1}	Auto tuning mode selection	Auto tuning mode selection ^{*5}	0	Setting	—	○	○	—	—
188 to 191 (BCH to BFH)	—	System area				—	—	—	—	—	—	—
192(C0H)	CH1	Alert 1 mode setting				0	Setting	—	○	○	○	—
193(C1H)	CH1	Alert 2 mode setting				0	Setting	—	○	○	○	—
194(C2H)	CH1	Alert 3 mode setting				0	Setting	—	○	○	○	—
195(C3H)	CH1	Alert 4 mode setting				0	Setting	—	○	○	○	—
196 to 200 (C4H to C8H)	—	System area				—	—	—	—	—	—	—
201(C9H)	CH1	Rate alarm alert output enable/disable setting				1	Setting	—	○	○	○	—
202(CAH)	CH1	Rate alarm alert detection cycle				1	Setting	—	○	○	○	—
203(CBH)	CH1	Rate alarm upper limit value				0	Setting	—	○	○	○	—
204(CCH)	CH1	Rate alarm lower limit value				0	Setting	—	○	○	○	—
205 to 207 (CDH to CFH)	—	System area				—	—	—	—	—	—	—
208(D0H)	CH2	Alert 1 mode setting		Alert 1 mode setting ^{*3}	Alert 1 mode setting	0	Setting	—	○	○	○	—
209(D1H)	CH2	Alert 2 mode setting		Alert 2 mode setting ^{*3}	Alert 2 mode setting	0	Setting	—	○	○	○	—
210(D2H)	CH2	Alert 3 mode setting		Alert 3 mode setting ^{*3}	Alert 3 mode setting	0	Setting	—	○	○	○	—
211(D3H)	CH2	Alert 4 mode setting		Alert 4 mode setting ^{*3}	Alert 4 mode setting	0	Setting	—	○	○	○	—
212 to 216 (D4H to D8H)	—	System area				—	—	—	—	—	—	—
217(D9H)	CH2	Rate alarm alert output enable/disable setting				1	Setting	—	○	○	○	—
218(DAH)	CH2	Rate alarm alert detection cycle				1	Setting	—	○	○	○	—
219(DBH)	CH2	Rate alarm upper limit value				0	Setting	—	○	○	○	—
220(DCH)	CH2	Rate alarm lower limit value				0	Setting	—	○	○	○	—
221 to 223 (DDH to DFH)	—	System area				—	—	—	—	—	—	—
224(E0H)	CH3	Alert 1 mode setting	Alert 1 mode setting ^{*1}	Alert 1 mode setting	Alert 1 mode setting ^{*5}	0	Setting	—	○	○	○	—
225(E1H)	CH3	Alert 2 mode setting	Alert 2 mode setting ^{*1}	Alert 2 mode setting	Alert 2 mode setting ^{*5}	0	Setting	—	○	○	○	—
226(E2H)	CH3	Alert 3 mode setting	Alert 3 mode setting ^{*1}	Alert 3 mode setting	Alert 3 mode setting ^{*5}	0	Setting	—	○	○	○	—
227(E3H)	CH3	Alert 4 mode setting	Alert 4 mode setting ^{*1}	Alert 4 mode setting	Alert 4 mode setting ^{*5}	0	Setting	—	○	○	○	—
228 to 232 (E4H to E8H)	—	System area				—	—	—	—	—	—	—
233(E9H)	CH3	Rate alarm alert output enable/disable setting				1	Setting	—	○	○	○	—
234(EAH)	CH3	Rate alarm alert detection cycle				1	Setting	—	○	○	○	—
235(EBH)	CH3	Rate alarm upper limit value				0	Setting	—	○	○	○	—
236(ECH)	CH3	Rate alarm lower limit value				0	Setting	—	○	○	○	—
237 to 239 (EDH to EFH)	—	System area				—	—	—	—	—	—	—

Address: Decimal (hexadecimal)	CH	Setting details				Default value	Data type	(1)	(2)	(3)	(4)	(5)
		Standard control	Heating- cooling control	Mix control	Position- proportional control							
240(F0H)	CH4	Alert 1 mode setting	Alert 1 mode setting ^{*1}	Alert 1 mode setting	Alert 1 mode setting ^{*5}	0	Setting	—	○	○	○	—
241(F1H)	CH4	Alert 2 mode setting	Alert 2 mode setting ^{*1}	Alert 2 mode setting	Alert 2 mode setting ^{*5}	0	Setting	—	○	○	○	—
242(F2H)	CH4	Alert 3 mode setting	Alert 3 mode setting ^{*1}	Alert 3 mode setting	Alert 3 mode setting ^{*5}	0	Setting	—	○	○	○	—
243(F3H)	CH4	Alert 4 mode setting	Alert 4 mode setting ^{*1}	Alert 4 mode setting	Alert 4 mode setting ^{*5}	0	Setting	—	○	○	○	—
244 to 248 (F4H to F8H)	—	System area				—	—	—	—	—	—	—
249(F9H)	CH4	Rate alarm alert output enable/disable setting				1	Setting	—	○	○	○	—
250(FAH)	CH4	Rate alarm alert detection cycle				1	Setting	—	○	○	○	—
251(FBH)	CH4	Rate alarm upper limit value				0	Setting	—	○	○	○	—
252(FCH)	CH4	Rate alarm lower limit value				0	Setting	—	○	○	○	—
253 to 255 (FDH to FFH)	—	System area				—	—	—	—	—	—	—
256(100H)	CT1	Heater current process value ^{*11}			System area	0	Monitor	—	—	—	—	○
257(101H)	CT2	Heater current process value ^{*11}			System area	0	Monitor	—	—	—	—	○
258(102H)	CT3	Heater current process value ^{*11}			System area	0	Monitor	—	—	—	—	○
259(103H)	CT4	Heater current process value ^{*11}			System area	0	Monitor	—	—	—	—	○
260(104H)	CT5	Heater current process value ^{*11}			System area	0	Monitor	—	—	—	—	○
261(105H)	CT6	Heater current process value ^{*11}			System area	0	Monitor	—	—	—	—	○
262(106H)	CT7	Heater current process value ^{*11}			System area	0	Monitor	—	—	—	—	○
263(107H)	CT8	Heater current process value ^{*11}			System area	0	Monitor	—	—	—	—	○
264(108H)	CT1	CT input channel assignment setting ^{*11}			System area	0	Setting	—	○	○	—	—
265(109H)	CT2	CT input channel assignment setting ^{*11}			System area	0	Setting	—	○	○	—	—
266(10AH)	CT3	CT input channel assignment setting ^{*11}			System area	0	Setting	—	○	○	—	—
267(10BH)	CT4	CT input channel assignment setting ^{*11}			System area	0	Setting	—	○	○	—	—
268(10CH)	CT5	CT input channel assignment setting ^{*11}			System area	0	Setting	—	○	○	—	—
269(10DH)	CT6	CT input channel assignment setting ^{*11}			System area	0	Setting	—	○	○	—	—
270(10EH)	CT7	CT input channel assignment setting ^{*11}			System area	0	Setting	—	○	○	—	—
271(10FH)	CT8	CT input channel assignment setting ^{*11}			System area	0	Setting	—	○	○	—	—
272(110H)	CT1	CT selection ^{*11}			System area	0	Setting	—	○	○	○	—
273(111H)	CT2	CT selection ^{*11}			System area	0	Setting	—	○	○	○	—
274(112H)	CT3	CT selection ^{*11}			System area	0	Setting	—	○	○	○	—
275(113H)	CT4	CT selection ^{*11}			System area	0	Setting	—	○	○	○	—
276(114H)	CT5	CT selection ^{*11}			System area	0	Setting	—	○	○	○	—
277(115H)	CT6	CT selection ^{*11}			System area	0	Setting	—	○	○	○	—
278(116H)	CT7	CT selection ^{*11}			System area	0	Setting	—	○	○	○	—
279(117H)	CT8	CT selection ^{*11}			System area	0	Setting	—	○	○	○	—
280(118H)	CT1	Reference heater current value ^{*11}			System area	0	Setting	—	○	○	—	—
281(119H)	CT2	Reference heater current value ^{*11}			System area	0	Setting	—	○	○	—	—
282(11AH)	CT3	Reference heater current value ^{*11}			System area	0	Setting	—	○	○	—	—
283(11BH)	CT4	Reference heater current value ^{*11}			System area	0	Setting	—	○	○	—	—
284(11CH)	CT5	Reference heater current value ^{*11}			System area	0	Setting	—	○	○	—	—
285(11DH)	CT6	Reference heater current value ^{*11}			System area	0	Setting	—	○	○	—	—
286(11EH)	CT7	Reference heater current value ^{*11}			System area	0	Setting	—	○	○	—	—
287(11FH)	CT8	Reference heater current value ^{*11}			System area	0	Setting	—	○	○	—	—
288(120H)	CT1	CT ratio setting ^{*11}			System area	800	Setting	—	○	○	—	—
289(121H)	CT2	CT ratio setting ^{*11}			System area	800	Setting	—	○	○	—	—
290(122H)	CT3	CT ratio setting ^{*11}			System area	800	Setting	—	○	○	—	—
291(123H)	CT4	CT ratio setting ^{*11}			System area	800	Setting	—	○	○	—	—

Address: Decimal (hexadecimal)	CH	Setting details				Default value	Data type	(1)	(2)	(3)	(4)	(5)
		Standard control	Heating- cooling control	Mix control	Position- proportional control							
292(124H)	CT5	CT ratio setting ^{*11}			System area	800	Setting	—	○	○	—	—
293(125H)	CT6	CT ratio setting ^{*11}			System area	800	Setting	—	○	○	—	—
294(126H)	CT7	CT ratio setting ^{*11}			System area	800	Setting	—	○	○	—	—
295(127H)	CT8	CT ratio setting ^{*11}			System area	800	Setting	—	○	○	—	—
296 to 543 (128H to 21FH)	—	System area				—	—	—	—	—	—	—
544(220H)	CH1	Sensor two-point correction offset value (measured value)				0	Setting	○	○	○	○	—
545(221H)	CH1	Sensor two-point correction offset value (corrected value)				0	Setting	○	○	○	○	—
546(222H)	CH1	Sensor two-point correction gain value (measured value)				0	Setting	○	○	○	○	—
547(223H)	CH1	Sensor two-point correction gain value (corrected value)				0	Setting	○	○	○	○	—
548(224H)	CH1	Sensor two-point correction offset latch request				0	Setting	—	—	○	—	—
549(225H)	CH1	Sensor two-point correction offset latch completion				0	Monitor	—	—	—	—	○
550(226H)	CH1	Sensor two-point correction gain latch request				0	Setting	—	—	○	—	—
551(227H)	CH1	Sensor two-point correction gain latch completion				0	Monitor	—	—	—	—	○
552 to 563 (228H to 233H)	—	System area				—	—	—	—	—	—	—
564(234H)	CH1	Setting variation rate limiter (temperature drop) ^{*13}				0	Setting	—	○	○	—	—
565 to 570 (235H to 23AH)	—	System area				—	—	—	—	—	—	—
571(23BH)	All	During AT loop disconnection detection function enable/ disable	System area	During AT loop disconnection detection function enable/ disable	System area	0	Setting	—	○	○	—	—
572(23CH)	—	System area				—	—	—	—	—	—	—
573(23DH)	CH1	AT simultaneous temperature rise parameter calculation flag	System area			0	Monitor	—	—	—	—	○
574(23EH)	CH1	Self-tuning setting	System area			0	Setting	—	○	○	—	—
575(23FH)	CH1	Self-tuning flag	System area			0	Monitor	—	—	—	—	○
576(240H)	CH2	Sensor two-point correction offset value (measured value)				0	Setting	○	○	○	○	—
577(241H)	CH2	Sensor two-point correction offset value (corrected value)				0	Setting	○	○	○	○	—
578(242H)	CH2	Sensor two-point correction gain value (measured value)				0	Setting	○	○	○	○	—
579(243H)	CH2	Sensor two-point correction gain value (corrected value)				0	Setting	○	○	○	○	—
580(244H)	CH2	Sensor two-point correction offset latch request				0	Setting	—	—	○	—	—
581(245H)	CH2	Sensor two-point correction offset latch completion				0	Monitor	—	—	—	—	○
582(246H)	CH2	Sensor two-point correction gain latch request				0	Setting	—	—	○	—	—
583(247H)	CH2	Sensor two-point correction gain latch completion				0	Monitor	—	—	—	—	○
584 to 595 (248H to 253H)	—	System area				—	—	—	—	—	—	—
596(254H)	CH2	Setting variation rate limiter (temperature drop) ^{*13}		Setting variation rate limiter (temperature drop) ^{*3*13}	Setting variation rate limiter (temperature drop) ^{*13}	0	Setting	—	○	○	—	—
597 to 604 (255H to 25CH)	—	System area				—	—	—	—	—	—	—
605(25DH)	CH2	AT simultaneous temperature rise parameter calculation flag	System area			0	Monitor	—	—	—	—	○
606(25EH)	CH2	Self-tuning setting	System area			0	Setting	—	○	○	—	—
607(25FH)	CH2	Self-tuning flag	System area			0	Monitor	—	—	—	—	○

Address: Decimal (hexadecimal)	CH	Setting details				Default value	Data type	(1)	(2)	(3)	(4)	(5)
		Standard control	Heating- cooling control	Mix control	Position- proportional control							
608(260H)	CH3	Sensor two-point correction offset value (measured value)				0	Setting	○	○	○	○	—
609(261H)	CH3	Sensor two-point correction offset value (corrected value)				0	Setting	○	○	○	○	—
610(262H)	CH3	Sensor two-point correction gain value (measured value)				0	Setting	○	○	○	○	—
611(263H)	CH3	Sensor two-point correction gain value (corrected value)				0	Setting	○	○	○	○	—
612(264H)	CH3	Sensor two-point correction offset latch request				0	Setting	—	—	○	—	—
613(265H)	CH3	Sensor two-point correction offset latch completion				0	Monitor	—	—	—	—	○
614(266H)	CH3	Sensor two-point correction gain latch request				0	Setting	—	—	○	—	—
615(267H)	CH3	Sensor two-point correction gain latch completion				0	Monitor	—	—	—	—	○
616 to 627 (268H to 273H)	—	System area				—	—	—	—	—	—	—
628(274H)	CH3	Setting variation rate limiter (temperature drop) ^{*13}	Setting variation rate limiter (temperature drop) ^{*13}	Setting variation rate limiter (temperature drop) ^{*13}	Setting variation rate limiter (temperature drop) ^{*5*13}	0	Setting	—	○	○	—	—
629 to 636 (275H to 27CH)	—	System area				—	—	—	—	—	—	—
637(27DH)	CH3	AT simultaneous temperature rise parameter calculation flag	System area	AT simultaneous temperature rise parameter calculation flag	System area	0	Monitor	—	—	—	—	○
638(27EH)	CH3	Self-tuning setting	System area	Self-tuning setting	System area	0	Setting	—	○	○	—	—
639(27FH)	CH3	Self-tuning flag	System area	Self-tuning flag	System area	0	Monitor	—	—	—	—	○
640(280H)	CH4	Sensor two-point correction offset value (measured value)				0	Setting	○	○	○	○	—
641(281H)	CH4	Sensor two-point correction offset value (corrected value)				0	Setting	○	○	○	○	—
642(282H)	CH4	Sensor two-point correction gain value (measured value)				0	Setting	○	○	○	○	—
643(283H)	CH4	Sensor two-point correction gain value (corrected value)				0	Setting	○	○	○	○	—
644(284H)	CH4	Sensor two-point correction offset latch request				0	Setting	—	—	○	—	—
645(285H)	CH4	Sensor two-point correction offset latch completion				0	Monitor	—	—	—	—	○
646(286H)	CH4	Sensor two-point correction gain latch request				0	Setting	—	—	○	—	—
647(287H)	CH4	Sensor two-point correction gain latch completion				0	Monitor	—	—	—	—	○
648 to 659 (288H to 293H)	—	System area				—	—	—	—	—	—	—
660(294H)	CH4	Setting variation rate limiter (temperature drop) ^{*13}	Setting variation rate limiter (temperature drop) ^{*13}	Setting variation rate limiter (temperature drop) ^{*13}	Setting variation rate limiter (temperature drop) ^{*5*13}	0	Setting	—	○	○	—	—
661 to 668 (295H to 29CH)	—	System area				—	—	—	—	—	—	—
669(29DH)	CH4	AT simultaneous temperature rise parameter calculation flag	System area	AT simultaneous temperature rise parameter calculation flag	System area	0	Monitor	—	—	—	—	○
670(29EH)	CH4	Self-tuning setting	System area	Self-tuning setting	System area	0	Setting	—	○	○	—	—
671(29FH)	CH4	Self-tuning flag	System area	Self-tuning flag	System area	0	Monitor	—	—	—	—	○
672 to 688 (2A0H to 2B0H)	—	System area				—	—	—	—	—	—	—
689(2B1H)	CH1	Temperature process value (PV) for input with another analog module				0	Setting	—	—	○	—	—
690(2B2H)	CH2	Temperature process value (PV) for input with another analog module		Temperature process value (PV) for input with another analog module ^{*3}	Temperature process value (PV) for input with another analog module	0	Setting	—	—	○	—	—

Address: Decimal (hexadecimal)	CH	Setting details				Default value	Data type	(1)	(2)	(3)	(4)	(5)
		Standard control	Heating- cooling control	Mix control	Position- proportional control							
691(2B3H)	CH3	Temperature process value (PV) for input with another analog module	Temperature process value (PV) for input with another analog module ^{*1}	Temperature process value (PV) for input with another analog module	Temperature process value (PV) for input with another analog module ^{*5}	0	Setting	—	—	○	—	—
692(2B4H)	CH4	Temperature process value (PV) for input with another analog module	Temperature process value (PV) for input with another analog module ^{*1}	Temperature process value (PV) for input with another analog module	Temperature process value (PV) for input with another analog module ^{*5}	0	Setting	—	—	○	—	—
693 to 694 (2B5H to 2B6H)	—	System area				—	—	—	—	—	—	—
695(2B7H)	CH2	System area		Temperature conversion setting ^{*4}	System area	0	Setting	—	○	○	—	—
696(2B8H)	CH3	System area	Temperature conversion setting ^{*2}	System area	Temperature conversion setting ^{*6}	0	Setting	—	○	○	—	—
697(2B9H)	CH4	System area	Temperature conversion setting ^{*2}	System area	Temperature conversion setting ^{*6}	0	Setting	—	○	○	—	—
698(2BAH)	CH1	Number of moving averaging setting				2	Setting	—	○	○	○	—
699(2BBH)	CH2	Number of moving averaging setting				2	Setting	—	○	○	○	—
700(2BCH)	CH3	Number of moving averaging setting				2	Setting	—	○	○	○	—
701(2BDH)	CH4	Number of moving averaging setting				2	Setting	—	○	○	○	—
702 to 703 (2BEH to 2BFH)	—	System area				—	—	—	—	—	—	—
704(2C0H)	CH1	System area	Manipulated value for cooling (MVc)		System area	0	Monitor	—	—	—	—	○
705(2C1H)	CH2	System area	Manipulated value for cooling (MVc)	Manipulated value for cooling (MVc) ^{*3}	System area	0	Monitor	—	—	—	—	○
706(2C2H)	CH3	System area	Manipulated value for cooling (MVc) ^{*1}	System area		0	Monitor	—	—	—	—	○
707(2C3H)	CH4	System area	Manipulated value for cooling (MVc) ^{*1}	System area		0	Monitor	—	—	—	—	○
708(2C4H)	CH1	System area	Manipulated value for cooling (MVc) for output with another analog module		System area	0	Monitor	—	—	—	—	○
709(2C5H)	CH2	System area	Manipulated value for cooling (MVc) for output with another analog module	Manipulated value for cooling (MVc) for output with another analog module ^{*3}	System area	0	Monitor	—	—	—	—	○
710(2C6H)	CH3	System area	Manipulated value for cooling (MVc) for output with another analog module ^{*1}	System area		0	Monitor	—	—	—	—	○
711(2C7H)	CH4	System area	Manipulated value for cooling (MVc) for output with another analog module ^{*1}	System area		0	Monitor	—	—	—	—	○
712(2C8H)	CH1	System area	Cooling transistor output flag		Close side transistor output flag	0	Monitor	—	—	—	—	○

Address: Decimal (hexadecimal)	CH	Setting details				Default value	Data type	(1)	(2)	(3)	(4)	(5)
		Standard control	Heating- cooling control	Mix control	Position- proportional control							
713(2C9H)	CH2	System area	Cooling transistor output flag	Cooling transistor output flag ^{*3}	Close side transistor output flag	0	Monitor	—	—	—	—	○
714(2CAH)	CH3	System area	Cooling transistor output flag ^{*1}	System area	Close side transistor output flag ^{*5}	0	Monitor	—	—	—	—	○
715(2CBH)	CH4	System area	Cooling transistor output flag ^{*1}	System area	Close side transistor output flag ^{*5}	0	Monitor	—	—	—	—	○
716 to 718 (2CCH to 2CEH)	—	System area				—	—	—	—	—	—	—
719(2CFH)	All	System area	Cooling method setting		System area	0	Setting	—	○	○	○	—
720(2D0H)	CH1	System area	Cooling proportional band (Pc) setting		System area	30	Setting	—	○	○	—	—
721(2D1H)	CH1	System area	Cooling upper limit output limiter		System area	1000	Setting	—	○	○	—	—
722(2D2H)	CH1	System area	Cooling control output cycle setting		System area	30 ^{*15} 300 ^{*16}	Setting	—	○	○	—	—
723(2D3H)	CH1	System area	Overlap/dead band setting		System area	0	Setting	—	○	○	—	—
724(2D4H)	CH1	Manual reset amount setting			System area	0	Setting	—	○	○	—	—
725(2D5H)	CH1	Process value (PV) scaling function enable/disable setting				0	Setting	—	○	○	○	—
726(2D6H)	CH1	Process value (PV) scaling lower limit value				0	Setting	—	○	○	○	—
727(2D7H)	CH1	Process value (PV) scaling upper limit value				0	Setting	—	○	○	○	—
728(2D8H)	CH1	Process value (PV) scaling value				0	Monitor	—	—	—	—	○
729(2D9H)	CH1	Derivative action selection			System area	0	Setting	—	○	○	○	—
730(2DAH)	CH1	Simultaneous temperature rise group setting	System area			0	Setting	—	○	○	○	—
731(2DBH)	CH1	Simultaneous temperature rise gradient data	System area			0	Setting	○	○	○	—	—
732(2DCH)	CH1	Simultaneous temperature rise dead time	System area			0	Setting	○	○	○	—	—
733(2DDH)	CH1	Simultaneous temperature rise AT mode selection	System area			0	Setting	—	○	○	—	—
734(2DEH)	CH1	Simultaneous temperature rise status	System area			0	Monitor	—	—	—	—	○
735(2DFH)	CH1	Setting variation rate limiter unit time setting				0	Setting	—	○	○	○	—
736(2E0H)	CH2	System area	Cooling proportional band (Pc) setting	Cooling proportional band (Pc) setting ^{*3}	System area	30	Setting	—	○	○	—	—
737(2E1H)	CH2	System area	Cooling upper limit output limiter	Cooling upper limit output limiter ^{*3}	System area	1000	Setting	—	○	○	—	—
738(2E2H)	CH2	System area	Cooling control output cycle setting	Cooling control output cycle setting ^{*3}	System area	30 ^{*15} 300 ^{*16}	Setting	—	○	○	—	—
739(2E3H)	CH2	System area	Overlap/dead band setting	Overlap/dead band setting ^{*3}	System area	0	Setting	—	○	○	—	—
740(2E4H)	CH2	Manual reset amount setting		Manual reset amount setting ^{*3}	System area	0	Setting	—	○	○	—	—



Address: Decimal (hexadecimal)	CH	Setting details				Default value	Data type	(1)	(2)	(3)	(4)	(5)
		Standard control	Heating- cooling control	Mix control	Position- proportional control							
741(2E5H)	CH2	Process value (PV) scaling function enable/disable setting		Process value (PV) scaling function enable/disable setting ^{*3}	Process value (PV) scaling function enable/disable setting	0	Setting	—	○	○	○	—
742(2E6H)	CH2	Process value (PV) scaling lower limit value		Process value (PV) scaling lower limit value ^{*3}	Process value (PV) scaling lower limit value	0	Setting	—	○	○	○	—
743(2E7H)	CH2	Process value (PV) scaling upper limit value		Process value (PV) scaling upper limit value ^{*3}	Process value (PV) scaling upper limit value	0	Setting	—	○	○	○	—
744(2E8H)	CH2	Process value (PV) scaling value		Process value (PV) scaling value ^{*3}	Process value (PV) scaling value	0	Monitor	—	—	—	—	○
745(2E9H)	CH2	Derivative action selection		Derivative action selection ^{*3}	System area	0	Setting	—	○	○	○	—
746(2EAH)	CH2	Simultaneous temperature rise group setting	System area			0	Setting	—	○	○	○	—
747(2EBH)	CH2	Simultaneous temperature rise gradient data	System area			0	Setting	○	○	○	—	—
748(2ECH)	CH2	Simultaneous temperature rise dead time	System area			0	Setting	○	○	○	—	—
749(2EDH)	CH2	Simultaneous temperature rise AT mode selection	System area			0	Setting	—	○	○	—	—
750(2EEH)	CH2	Simultaneous temperature rise status	System area	System area	System area	0	Monitor	—	—	—	—	○
751(2EFH)	CH2	Setting variation rate limiter unit time setting		Setting variation rate limiter unit time setting ^{*3}	Setting variation rate limiter unit time setting	0	Setting	—	○	○	○	—
752(2F0H)	CH3	System area	Cooling proportional band (Pc) setting ^{*1}	System area		30	Setting	—	○	○	—	—
753(2F1H)	CH3	System area	Cooling upper limit output limiter ^{*1}	System area		1000	Setting	—	○	○	—	—
754(2F2H)	CH3	System area	Cooling control output cycle setting ^{*1}	System area		30 ^{*15} 300 ^{*16}	Setting	—	○	○	—	—
755(2F3H)	CH3	System area	Overlap/dead band setting ^{*1}	System area		0	Setting	—	○	○	—	—
756(2F4H)	CH3	Manual reset amount setting	Manual reset amount setting ^{*1}	Manual reset amount setting	System area	0	Setting	—	○	○	—	—
757(2F5H)	CH3	Process value (PV) scaling function enable/disable setting	Process value (PV) scaling function enable/disable setting ^{*1}	Process value (PV) scaling function enable/disable setting	Process value (PV) scaling function enable/disable setting ^{*5}	0	Setting	—	○	○	○	—
758(2F6H)	CH3	Process value (PV) scaling lower limit value	Process value (PV) scaling lower limit value ^{*1}	Process value (PV) scaling lower limit value	Process value (PV) scaling lower limit value ^{*5}	0	Setting	—	○	○	○	—

Address: Decimal (hexadecimal)	CH	Setting details				Default value	Data type	(1)	(2)	(3)	(4)	(5)
		Standard control	Heating- cooling control	Mix control	Position- proportional control							
759(2F7H)	CH3	Process value (PV) scaling upper limit value	Process value (PV) scaling upper limit value ^{*1}	Process value (PV) scaling upper limit value	Process value (PV) scaling upper limit value ^{*5}	0	Setting	—	○	○	○	—
760(2F8H)	CH3	Process value (PV) scaling value	Process value (PV) scaling value ^{*1}	Process value (PV) scaling value	Process value (PV) scaling value ^{*5}	0	Monitor	—	—	—	—	○
761(2F9H)	CH3	Derivative action selection	Derivative action selection ^{*1}	Derivative action selection	System area	0	Setting	—	○	○	○	—
762(2FAH)	CH3	Simultaneous temperature rise group setting	System area	Simultaneous temperature rise group setting	System area	0	Setting	—	○	○	○	—
763(2FBH)	CH3	Simultaneous temperature rise gradient data	System area	Simultaneous temperature rise gradient data	System area	0	Setting	○	○	○	—	—
764(2FCH)	CH3	Simultaneous temperature rise dead time	System area	Simultaneous temperature rise dead time	System area	0	Setting	○	○	○	—	—
765(2FDH)	CH3	Simultaneous temperature rise AT mode selection	System area	Simultaneous temperature rise AT mode selection	System area	0	Setting	—	○	○	—	—
766(2FEH)	CH3	Simultaneous temperature rise status	System area	Simultaneous temperature rise status	System area	0	Monitor	—	—	—	—	○
767(2FFH)	CH3	Setting variation rate limiter unit time setting	Setting variation rate limiter unit time setting ^{*1}	Setting variation rate limiter unit time setting	Setting variation rate limiter unit time setting ^{*5}	0	Setting	—	○	○	○	—
768(300H)	CH4	System area	Cooling proportional band (Pc) setting ^{*1}	System area		30	Setting	—	○	○	—	—
769(301H)	CH4	System area	Cooling upper limit output limiter ^{*1}	System area		1000	Setting	—	○	○	—	—
770(302H)	CH4	System area	Cooling control output cycle setting ^{*1}	System area		30 ^{*15} 300 ^{*16}	Setting	—	○	○	—	—
771(303H)	CH4	System area	Overlap/dead band setting ^{*1}	System area		0	Setting	—	○	○	—	—
772(304H)	CH4	Manual reset amount setting	Manual reset amount setting ^{*1}	Manual reset amount setting	System area	0	Setting	—	○	○	—	—
773(305H)	CH4	Process value (PV) scaling function enable/disable setting	Process value (PV) scaling function enable/disable setting ^{*1}	Process value (PV) scaling function enable/disable setting	Process value (PV) scaling function enable/disable setting ^{*5}	0	Setting	—	○	○	○	—
774(306H)	CH4	Process value (PV) scaling lower limit value	Process value (PV) scaling lower limit value ^{*1}	Process value (PV) scaling lower limit value	Process value (PV) scaling lower limit value ^{*5}	0	Setting	—	○	○	○	—
775(307H)	CH4	Process value (PV) scaling upper limit value	Process value (PV) scaling upper limit value ^{*1}	Process value (PV) scaling upper limit value	Process value (PV) scaling upper limit value ^{*5}	0	Setting	—	○	○	○	—
776(308H)	CH4	Process value (PV) scaling value	Process value (PV) scaling value ^{*1}	Process value (PV) scaling value	Process value (PV) scaling value ^{*5}	0	Monitor	—	—	—	—	○
777(309H)	CH4	Derivative action selection	Derivative action selection ^{*1}	Derivative action selection	System area	0	Setting	—	○	○	○	—



Address: Decimal (hexadecimal)	CH	Setting details				Default value	Data type	(1)	(2)	(3)	(4)	(5)
		Standard control	Heating- cooling control	Mix control	Position- proportional control							
778(30AH)	CH4	Simultaneous temperature rise group setting	System area	Simultaneous temperature rise group setting	System area	0	Setting	—	○	○	○	—
779(30BH)	CH4	Simultaneous temperature rise gradient data	System area	Simultaneous temperature rise gradient data	System area	0	Setting	○	○	○	—	—
780(30CH)	CH4	Simultaneous temperature rise dead time	System area	Simultaneous temperature rise dead time	System area	0	Setting	○	○	○	—	—
781(30DH)	CH4	Simultaneous temperature rise AT mode selection	System area	Simultaneous temperature rise AT mode selection	System area	0	Setting	—	○	○	—	—
782(30EH)	CH4	Simultaneous temperature rise status	System area	Simultaneous temperature rise status	System area	0	Monitor	—	—	—	—	○
783(30FH)	CH4	Setting variation rate limiter unit time setting	Setting variation rate limiter unit time setting ^{*1}	Setting variation rate limiter unit time setting	Setting variation rate limiter unit time setting ^{*5}	0	Setting	—	○	○	○	—
784(310H)	All	Peak current suppression control group setting	System area	System area	System area	0	Setting	—	○	○	○	—
785(311H)	All	Sensor correction function selection				0	Setting	—	○	○	○	—
786(312H)	All	Temperature conversion completion flag				0	Monitor	—	—	—	—	○
787(313H)	All	Function extension bit monitor				0	Monitor	—	—	—	—	—
788(314H)	All	Sampling cycle monitor				0	Monitor	—	—	—	—	—
789 to 1023 (315H to 3FFH)	—	System area				—	—	—	—	—	—	—
1024(400H)	All	Sampling cycle and function extension setting ^{*14}				0	Setting	—	○	—	○	—
1025(401H)	All	Control mode selection				0	Setting	—	○	—	○	—
1026(402H)	All	HOLD/CLEAR setting				0	Setting	—	○	—	○	—
1027 to 1039 (403H to 40FH)	—	System area				—	—	—	—	—	—	—
1040(410H)	CH1	System area			Open/close output neutral band setting	20	Setting	—	○	○	○	—
1041(411H)	CH1	System area			Control motor time	10	Setting	—	○	○	○	—
1042(412H)	CH1	System area			Integration output limiter setting	1500	Setting	—	○	○	○	—
1043(413H)	CH1	System area			Valve operation setting during CPU module STOP	0	Setting	—	○	○	○	—
1044(414H)	CH1	Disturbance judgment position			System area	0	Setting	○	○	○	—	—
1045(415H)	CH1	Set value return adjustment			System area	0	Setting	—	○	○	—	—
1046(416H)	CH1	Feed forward control forced starting signal			System area	0	Setting	—	—	○	—	—
1047(417H)	CH1	Feed forward value			System area	0	Setting	—	○	○	—	—
1048(418H)	CH1	Feed forward value tuning selection			System area	0	Setting	—	—	○	—	—
1049(419H)	CH1	Auto tuning error judgment time			120	Setting	—	○	○	—	—	
1050(41AH)	CH1	Overshoot suppression level setting			0	Setting	—	○	○	—	—	
1051(41BH)	CH1	Heater disconnection judgment mode ^{*11}			System area	0	Setting	—	○	○	○	—
1052 to 1055 (41CH to 41FH)	—	System area				—	—	—	—	—	—	—

Address: Decimal (hexadecimal)	CH	Setting details				Default value	Data type	(1)	(2)	(3)	(4)	(5)
		Standard control	Heating- cooling control	Mix control	Position- proportional control							
1056(420H)	CH2	System area			Open/close output neutral band setting	20	Setting	—	○	○	○	—
1057(421H)	CH2	System area			Control motor time	10	Setting	—	○	○	○	—
1058(422H)	CH2	System area			Integration output limiter setting	1500	Setting	—	○	○	○	—
1059(423H)	CH2	System area			Valve operation setting during CPU module STOP	0	Setting	—	○	○	○	—
1060(424H)	CH2	Disturbance judgment position		Disturbance judgment position ^{*3}	System area	0	Setting	○	○	○	—	—
1061(425H)	CH2	Set value return adjustment		Set value return adjustment ^{*3}	System area	0	Setting	—	○	○	—	—
1062(426H)	CH2	Feed forward control forced starting signal		Feed forward control forced starting signal ^{*3}	System area	0	Setting	—	—	○	—	—
1063(427H)	CH2	Feed forward value		Feed forward value ^{*3}	System area	0	Setting	—	○	○	—	—
1064(428H)	CH2	Feed forward value tuning selection		Feed forward value tuning selection ^{*3}	System area	0	Setting	—	—	○	—	—
1065(429H)	CH2	Auto tuning error judgment time		Auto tuning error judgment time ^{*3}	Auto tuning error judgment time	120	Setting	—	○	○	—	—
1066(42AH)	CH2	Overshoot suppression level setting		Overshoot suppression level setting ^{*3}	Overshoot suppression level setting	0	Setting	—	○	○	—	—
1067(42BH)	CH2	Heater disconnection judgment mode ^{*11}		System area		0	Setting	—	○	○	○	—
1068 to 1071 (42CH to 42FH)	—	System area				—	—	—	—	—	—	—
1072(430H)	CH3	System area			Open/close output neutral band setting ^{*5}	20	Setting	—	○	○	○	—
1073(431H)	CH3	System area			Control motor time ^{*5}	10	Setting	—	○	○	○	—
1074(432H)	CH3	System area			Integration output limiter setting ^{*5}	1500	Setting	—	○	○	○	—
1075(433H)	CH3	System area			Valve operation setting during CPU module STOP ^{*5}	0	Setting	—	○	○	○	—
1076(434H)	CH3	Disturbance judgment position	Disturbance judgment position ^{*1}	Disturbance judgment position	System area	0	Setting	○	○	○	—	—
1077(435H)	CH3	Set value return adjustment	Set value return adjustment ^{*1}	Set value return adjustment	System area	0	Setting	—	○	○	—	—
1078(436H)	CH3	Feed forward control forced starting signal	Feed forward control forced starting signal ^{*1}	Feed forward control forced starting signal	System area	0	Setting	—	—	○	—	—
1079(437H)	CH3	Feed forward value	Feed forward value ^{*1}	Feed forward value	System area	0	Setting	—	○	○	—	—
1080(438H)	CH3	Feed forward value tuning selection	Feed forward value tuning selection ^{*1}	Feed forward value tuning selection	System area	0	Setting	—	—	○	—	—

Address: Decimal (hexadecimal)	CH	Setting details				Default value	Data type	(1)	(2)	(3)	(4)	(5)
		Standard control	Heating- cooling control	Mix control	Position- proportional control							
1081(439H)	CH3	Auto tuning error judgment time	Auto tuning error judgment time* ¹	Auto tuning error judgment time	Auto tuning error judgment time* ⁵	120	Setting	—	○	○	—	—
1082(43AH)	CH3	Overshoot suppression level setting	Overshoot suppression level setting* ¹	Overshoot suppression level setting	Overshoot suppression level setting* ⁵	0	Setting	—	○	○	—	—
1083(43BH)	CH3	Heater disconnection judgment mode* ¹¹	System area	Heater disconnection judgment mode* ¹¹	System area	0	Setting	—	○	○	○	—
1084 to 1087 (43CH to 43FH)	—	System area				—	—	—	—	—	—	—
1088(440H)	CH4	System area			Open/close output neutral band setting* ⁵	20	Setting	—	○	○	○	—
1089(441H)	CH4	System area			Control motor time* ⁵	10	Setting	—	○	○	○	—
1090(442H)	CH4	System area			Integration output limiter setting* ⁵	1500	Setting	—	○	○	○	—
1091(443H)	CH4	System area			Valve operation setting during CPU module STOP* ⁵	0	Setting	—	○	○	○	—
1092(444H)	CH4	Disturbance judgment position	Disturbance judgment position* ¹	Disturbance judgment position	System area	0	Setting	○	○	○	—	—
1093(445H)	CH4	Set value return adjustment	Set value return adjustment* ¹	Set value return adjustment	System area	0	Setting	—	○	○	—	—
1094(446H)	CH4	Feed forward control forced starting signal	Feed forward control forced starting signal* ¹	Feed forward control forced starting signal	System area	0	Setting	—	—	○	—	—
1095(447H)	CH4	Feed forward value	Feed forward value* ¹	Feed forward value	System area	0	Setting	—	○	○	—	—
1096(448H)	CH4	Feed forward value tuning selection	Feed forward value tuning selection* ¹	Feed forward value tuning selection	System area	0	Setting	—	—	○	—	—
1097(449H)	CH4	Auto tuning error judgment time	Auto tuning error judgment time* ¹	Auto tuning error judgment time	Auto tuning error judgment time* ⁵	120	Setting	—	○	○	—	—
1098(44AH)	CH4	Overshoot suppression level setting	Overshoot suppression level setting* ¹	Overshoot suppression level setting	Overshoot suppression level setting* ⁵	0	Setting	—	○	○	—	—
1099(44BH)	CH4	Heater disconnection judgment mode* ¹¹	System area	Heater disconnection judgment mode* ¹¹	System area	0	Setting	—	○	○	○	—
1100 to 1199 (44CH to 4AFH)	—	System area				—	—	—	—	—	—	—
1200(4B0H)	CH1	Feed forward value memory read command			System area	0	Control	—	—	○	—	—
1201 to 1215 (4B1H to 4BFH)	—	System area				—	—	—	—	—	—	—
1216(4C0H)	CH2	Feed forward value memory read command		Feed forward value memory read command* ³	System area	0	Control	—	—	○	—	—
1217 to 1231 (4C1H to 4CFH)	—	System area				—	—	—	—	—	—	—

Address: Decimal (hexadecimal)	CH	Setting details				Default value	Data type	(1)	(2)	(3)	(4)	(5)
		Standard control	Heating- cooling control	Mix control	Position- proportional control							
1232(4D0H)	CH3	Feed forward value memory read command	Feed forward value memory read command*1	Feed forward value memory read command	System area	0	Control	—	—	○	—	—
1233 to 1247 (4D1H to 4DFH)	—	System area				—	—	—	—	—	—	—
1248(4E0H)	CH4	Feed forward value memory read command	Feed forward value memory read command*1	Feed forward value memory read command	System area	0	Control	—	—	○	—	—
1249 to 1279 (4E1H to 4FFH)	—	System area				—	—	—	—	—	—	—
1280(500H)	All	Inter-module peak current suppression function state monitor	System area			0	Monitor	—	—	—	—	○
1281(501H)	All	Inter-module peak current suppression function enable/ disable monitor	System area			0	Monitor	—	—	—	—	—
1282(502H)	All	Inter-module peak current suppression function master/ slave selection monitor	System area			0	Monitor	—	—	—	—	—
1283(503H)	All	Number of slave modules with inter-module peak current suppression function enabled ⁹	System area			0	Monitor	—	—	—	—	—
1284 to 1346 (504H to 542H)	All	Start I/O of slave module with inter-module peak current suppression function enabled ⁹	System area			0	Monitor	—	—	—	—	—
1347 to 1349 (543H to 545H)	—	System area				—	—	—	—	—	—	—
1350(546H)	All	Inter-module simultaneous temperature rise function state monitor	System area	Inter-module simultaneous temperature rise function state monitor	System area	0	Monitor	—	—	—	—	○
1351(547H)	All	Inter-module simultaneous temperature rise function enable/ disable monitor	System area	Inter-module simultaneous temperature rise function enable/ disable monitor	System area	0	Monitor	—	—	—	—	—
1352(548H)	All	Inter-module simultaneous temperature rise function master/ slave selection monitor	System area	Inter-module simultaneous temperature rise function master/ slave selection monitor	System area	0	Monitor	—	—	—	—	—

Address: Decimal (hexadecimal)	CH	Setting details				Default value	Data type	(1)	(2)	(3)	(4)	(5)
		Standard control	Heating- cooling control	Mix control	Position- proportional control							
1353(549H)	All	Number of slave modules with inter-module simultaneous temperature rise function enabled ^{*8}	System area	Number of slave modules with inter-module simultaneous temperature rise function enabled ^{*8}	System area	0	Monitor	—	—	—	—	—
1354 to 1416 (54AH to 588H)	All	Start I/O of slave module with inter-module simultaneous temperature rise function enabled ^{*8}	System area	Start I/O of slave module with inter-module simultaneous temperature rise function enabled ^{*8}	System area	0	Monitor	—	—	—	—	—
1417(589H)	All	Feed forward value read completion flag			System area	0	Monitor	—	—	—	—	—
1418 to 1449 (58AH to 5A9H)	—	System area				—	—	—	—	—	—	—
1450(5AAH)	CH1	Feed forward control forced start status			System area	0	Monitor	—	—	—	—	○
1451(5ABH)	CH2	Feed forward control forced start status		Feed forward control forced start status ^{*3}	System area	0	Monitor	—	—	—	—	○
1452(5ACH)	CH3	Feed forward control forced start status	Feed forward control forced start status ^{*1}	Feed forward control forced start status	System area	0	Monitor	—	—	—	—	○
1453(5ADH)	CH4	Feed forward control forced start status	Feed forward control forced start status ^{*1}	Feed forward control forced start status	System area	0	Monitor	—	—	—	—	○
1454(5AEH)	CH1	Feed forward value tuning flag			System area	0	Monitor	—	—	—	—	○
1455(5AFH)	CH2	Feed forward value tuning flag		Feed forward value tuning flag ^{*3}	System area	0	Monitor	—	—	—	—	○
1456(5B0H)	CH3	Feed forward value tuning flag	Feed forward value tuning flag ^{*1}	Feed forward value tuning flag	System area	0	Monitor	—	—	—	—	○
1457(5B1H)	CH4	Feed forward value tuning flag	Feed forward value tuning flag ^{*1}	Feed forward value tuning flag	System area	0	Monitor	—	—	—	—	○
1458(5B2H)	CH1	Feed forward control READY flag			System area	0	Monitor	—	—	—	—	○
1459(5B3H)	CH2	Feed forward control READY flag		Feed forward control READY flag ^{*3}	System area	0	Monitor	—	—	—	—	○
1460(5B4H)	CH3	Feed forward control READY flag	Feed forward control READY flag ^{*1}	Feed forward control READY flag	System area	0	Monitor	—	—	—	—	○
1461(5B5H)	CH4	Feed forward control READY flag	Feed forward control READY flag ^{*1}	Feed forward control READY flag	System area	0	Monitor	—	—	—	—	○
1462(5B6H)	CH1	Feed forward control forced start READY flag			System area	0	Monitor	—	—	—	—	○
1463(5B7H)	CH2	Feed forward control forced start READY flag		Feed forward control forced start READY flag ^{*3}	System area	0	Monitor	—	—	—	—	○
1464(5B8H)	CH3	Feed forward control forced start READY flag	Feed forward control forced start READY flag ^{*1}	Feed forward control forced start READY flag	System area	0	Monitor	—	—	—	—	○
1465H(5B9H)	CH4	Feed forward control forced start READY flag	Feed forward control forced start READY flag ^{*1}	Feed forward control forced start READY flag	System area	0	Monitor	—	—	—	—	○

Address: Decimal (hexadecimal)	CH	Setting details				Default value	Data type	(1)	(2)	(3)	(4)	(5)
		Standard control	Heating- cooling control	Mix control	Position- proportional control							
1466 to 1535 (5BAH to 5FFH)	—	System area				—	—	—	—	—	—	—
1536(600H)	All	Latest address of error history				0	Monitor	—	—	—	—	○
1537(601H)	All	Error address				0	Monitor	—	—	—	—	○
1538(602H)	All	Latest alarm code				0	Monitor	—	—	—	—	○
1539(603H)	All	Latest address of alarm history				0	Monitor	—	—	—	—	○
1540 to 1999 (604H to 7CFH)	—	System area				—	—	—	—	—	—	—
2000 to 2159 (7D0H to 86FH)	All	Error history				0	Monitor	—	—	—	—	—
2160 to 2319 (870H to 90FH)	All	Alarm history				0	Monitor	—	—	—	—	—
2320 to 2999 (910H to BB7H)	—	System area				—	—	—	—	—	—	—
3000 to 3015 (BB8H to BC7H)	All	Interrupt factor detection flag [n] ¹⁷				0	Monitor	—	—	—	—	○
3016 to 3031 (BC8H to BD7H)	—	System area				—	—	—	—	—	—	—
3032 to 3047 (BD8H to BE7H)	All	Interrupt factor mask [n] ¹⁷				0	Control	—	—	—	—	—
3048 to 3063 (BE8H to BF7H)	—	System area				—	—	—	—	—	—	—
3064 to 3079 (BF8H to C07H)	All	Interrupt factor reset request [n] ¹⁷				0	Control	—	—	—	—	—
3080 to 3095 (C08H to C17H)	—	System area				—	—	—	—	—	—	—
3096 to 3111 (C18H to C27H)	All	Interrupt factor generation setting [n] ¹⁷				0	Setting	—	—	—	○	—
3112 to 3127 (C28H to C37H)	—	System area				—	—	—	—	—	—	—
3128 to 3143 (C38H to C47H)	All	Condition target setting [n] ¹⁷				0	Setting	—	—	—	○	—
3144 to 3159 (C48H to C57H)	—	System area				—	—	—	—	—	—	—
3160 to 3175 (C58H to C67H)	All	Condition target channel setting [n] ¹⁷				0	Setting	—	—	—	○	—
3176 or later (C68H or later)	—	System area				—	—	—	—	—	—	—

A

- *1 Enabled only when 'Control mode selection' (in the Q compatible mode) (Un\G1025) has been set to Heating-cooling control (expanded mode) (2). When Heating-cooling control (normal mode) (1) is set, this area becomes a system area.
- *2 Enabled only when 'Control mode selection' (in the Q compatible mode) (Un\G1025) has been set to Heating-cooling control (normal mode) (1). When Heating-cooling control (expanded mode) (2) is set, this area becomes a system area.
- *3 Enabled only when 'Control mode selection' (in the Q compatible mode) (Un\G1025) has been set to Mix control (expanded mode) (4). When Mix control (normal mode) (3) is set, this area becomes a system area.
- *4 Enabled only when 'Control mode selection' (in the Q compatible mode) (Un\G1025) has been set to Mix control (normal mode) (3). When Mix control (expanded mode) (4) is set, this area becomes a system area.
- *5 Enabled only when 'Control mode selection' (in the Q compatible mode) (Un\G1025) has been set to Position-proportional control (expanded mode) (6). When Position-proportional control (normal mode) (5) is set, this area becomes a system area.
- *6 Enabled only when 'Control mode selection' (in the Q compatible mode) (Un\G1025) has been set to Position-proportional control (normal mode) (5). When Position-proportional control (expanded mode) (6) is set, this area becomes a system area.
- *7 [n] in this table indicates an interrupt setting value. (n = 1 to 16)
- *8 This value is displayed only in the master module of the inter-module simultaneous temperature rise function. When multiple master modules have been set, 0 is stored in this area.
- *9 This value is displayed only in the master module of the inter-module peak current suppression function. When multiple master modules have been set, 0 is stored in this area.
- *10 This setting differs depending on whether Setting variation rate limiter setting (in the Q compatible mode) (Un\G1024, b1) is set to Individually set at temperature rise/temperature drop (1).
- *11 Enabled only when the R60TCRT2TT2BW or R60TCRT4BW is used.
- *12 Enabled only when the R60TCRT2TT2 or R60TCRT2TT2BW is used.
- *13 Enabled only when Setting variation rate limiter setting (in the Q compatible mode) (Un\G1024, b1) has been set to Individually set at temperature rise/temperature drop (1).
- *14 Automatic setting at input range change, setting variation rate limiter setting, control output cycle unit, and moving average processing setting can be configured.
- *15 When the control output cycle unit selection setting is 1s cycle
- *16 When the control output cycle unit selection setting is 0.1s cycle

Details of buffer memory addresses

This section describes the details of buffer memory addresses of the temperature control module.



This section describes the buffer memory addresses for CH1.

Latest error code

The latest error code detected by the temperature control module is stored. For error codes, refer to the following.

Page 142 List of Error Codes

■ Buffer memory address

The following shows the buffer memory address of this area.

Buffer memory area name	CH1	CH2	CH3	CH4
Latest error code	0			
Latest error code (in the Q compatible mode)	0			

Error address

The address where an error has occurred is stored.

■ Buffer memory address

The following shows the buffer memory address of this area.

Buffer memory area name	CH1	CH2	CH3	CH4
Error address	1			
Error address (in the Q compatible mode)	1537			

Latest address of error history

Among 'Error history' (Un\G3600 to Un\G3759), the buffer memory address where the latest error code has been stored is stored.

■ Buffer memory address

The following shows the buffer memory address of this area.

Buffer memory area name	CH1	CH2	CH3	CH4
Latest address of error history	2			
Latest address of error history (in the Q compatible mode)	1536			

Latest alarm code

The latest alarm code detected by the temperature control module is stored. For details, refer to the following.

Page 146 List of Alarm Codes

■ Buffer memory address

The following shows the buffer memory address of this area.

Buffer memory area name	CH1	CH2	CH3	CH4
Latest alarm code	3			
Latest alarm code (in the Q compatible mode)	1538			

Latest address of alarm history

Among 'Alarm history' (Un\G3760 to Un\G3919), the buffer memory address where the latest alarm code has been stored is stored.

■Buffer memory address

The following shows the buffer memory address of this area.

Buffer memory area name	CH1	CH2	CH3	CH4
Latest address of alarm history	4			
Latest address of alarm history (in the Q compatible mode)	1539			

Interrupt factor detection flag [n]

The detection status of an interrupt factor is stored.

Monitored value	Description
0	No interrupt factor
1	Interrupt factor

When an interrupt factor occurs, an interrupt request is sent to the CPU module at the same time as 'Interrupt factor detection flag [n]' (Un\G5 to Un\G20) is turned to Interrupt factor (1).

"n" indicates an interrupt setting number. (n = 1 to 16)

■Buffer memory address

The following shows the buffer memory address of this area.

Buffer memory area name	1	2	3	4	5	6	7	8	9	10	11	12	13	14	15	16
Interrupt factor detection flag [n]	5	6	7	8	9	10	11	12	13	14	15	16	17	18	19	20
Interrupt factor detection flag [n] (in the Q compatible mode)	3000	3001	3002	3003	3004	3005	3006	3007	3008	3009	3010	3011	3012	3013	3014	3015

Control mode selection monitor

The setting of 'Control mode selection' (Un\G300) is stored in this area. The following table lists stored values and the details.

- 0H: Standard control
- 1H: Heating-cooling control (normal mode)
- 2H: Heating-cooling control (expanded mode)
- 3H: Mix control (normal mode)
- 4H: Mix control (expanded mode)
- 5H: Position-proportional control (normal mode)
- 6H: Position-proportional control (expanded mode)

For details on the modes, refer to the following.

☞ Page 14 Control Mode Selection Function

■Buffer memory address

The following shows the buffer memory address of this area.

Buffer memory area name	CH1	CH2	CH3	CH4
Control mode selection monitor	37			
Control mode selection monitor (in the Q compatible mode)	183			

Sampling cycle monitor

The present sampling cycle is stored.

- 0: 500ms/4 channels
- 1: 250ms/4 channels

Set the sampling cycle in 'Sampling cycle selection' (Un\G301). In the Q compatible mode, set the sampling cycle in 'Sampling cycle selection' (in the Q compatible mode) (Un\G1024, b12).

■Buffer memory address

The following shows the buffer memory address of this area.

Buffer memory area name	CH1	CH2	CH3	CH4
Sampling cycle monitor	38			
Sampling cycle monitor (in the Q compatible mode)	788			

Automatic setting monitor at input range change

The value set in 'Automatic setting at input range change' (Un\G302) is stored.

■Buffer memory address

The following shows the buffer memory address of this area.

Buffer memory area name	CH1	CH2	CH3	CH4
Automatic setting monitor at input range change	39			

Setting variation rate limiter setting selection monitor

The value set in 'Setting variation rate limiter setting' (Un\G303) is stored.

■Buffer memory address

The following shows the buffer memory address of this area.

Buffer memory area name	CH1	CH2	CH3	CH4
Setting variation rate limiter setting selection monitor	40			

Control output cycle unit monitor

The value set in 'Control output cycle unit selection setting' (Un\G304) is stored.

■Buffer memory address

The following shows the buffer memory address of this area.

Buffer memory area name	CH1	CH2	CH3	CH4
Control output cycle unit monitor	41			

Moving average processing setting monitor

The value set in 'Moving average processing setting' (Un\G305) is stored.

■Buffer memory address

The following shows the buffer memory address of this area.

Buffer memory area name	CH1	CH2	CH3	CH4
Moving average processing setting monitor	42			

Temperature conversion completion flag

This flag is for checking whether the temperature conversion has been completed properly for each channel. One of the following values is stored in this area.

- 0: In conversion or channel not used
- 1: First temperature conversion completed

When the temperature is being converted or the channel is not used, In conversion or channel not used (0) is stored in this area. When the first temperature conversion is completed and a temperature process value (PV) is stored in the buffer memory, First temperature conversion completed (1) is stored in this area. The following figure shows the channel assignment of this area.

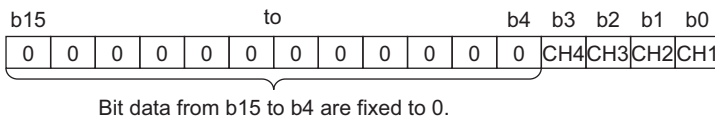

■ Buffer memory address

The following shows the buffer memory address of this area.

Buffer memory area name	CH1	CH2	CH3	CH4
Temperature conversion completion flag	43			

Temperature conversion completion flag (Q-compatible mode)

In the Q compatible mode, this flag is for checking whether the temperature conversion has been completed properly for each channel. One of the following values is stored in this area.

- 0: In conversion or channel not used
- 1: First temperature conversion completed

When the temperature is being converted or the channel is not used, In conversion or channel not used (0) is stored in this area. When the first temperature conversion is completed and a temperature process value (PV) is stored in the buffer memory, First temperature conversion completed (1) is stored in this area. The following figure shows the channel assignment of this area.

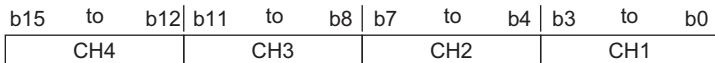

■ Buffer memory address

The following shows the buffer memory address of this area.

Buffer memory area name	CH1	CH2	CH3	CH4
Temperature conversion completion flag (in the Q compatible mode)	786			

MAN mode shift completion flag

This flag is for checking whether the mode shift has been completed when the mode was shifted from the AUTO (automatic) mode to the MAN (manual) mode. One of the following values is stored in this area.

- 0: Shift to MAN mode not completed
- 1: Shift to MAN mode completed

The following figure shows the correspondence between each bit of the buffer memory area and each channel.

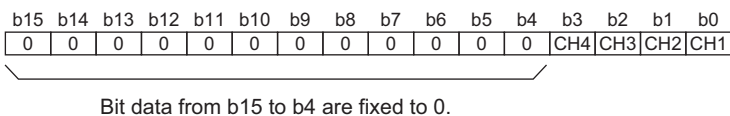

When the mode shift to the MAN mode is completed, a bit corresponding to the channel turns to Shift to MAN mode completed (1).

■Buffer memory address

The following shows the buffer memory address of this area.

Buffer memory area name	CH1	CH2	CH3	CH4
MAN mode shift completion flag	44			
MAN mode shift completion flag (in the Q compatible mode)	30			

■How to shift the mode

Shift the mode with 'CH1 AUTO/MAN mode shift' (Un\G518). (☞ Page 263 CH1 AUTO/MAN mode shift)

■Setting a manipulated value (MV) in the MAN mode

Set a manipulated value (MV) with 'CH1 MAN output setting' (Un\G519). (☞ Page 264 CH1 MAN output setting)

Set a manipulated value (MV) after checking that MAN mode shift completion flag (Un\G44) has changed to Shift to MAN mode completed (1).

Cold junction temperature process value

The measured temperature of the cold junction temperature compensation resistor is stored in this area.

The value to be stored differs depending on the temperature unit of 'CH1 Input range' (Un\G501). (☞ Page 247 CH1 Input range)

- When the temperature unit is °C: -10 to 100
- When the temperature unit is °F: 14 to 212

Point

Operations of the temperature control module are guaranteed at the ambient temperature of 0°C to 55°C.
For the general specifications of the temperature control module, refer to the following.

📖 MELSEC iQ-R Module Configuration Manual

■Buffer memory address

The following shows the buffer memory address of this area.

Buffer memory area name	CH1	CH2	CH3	CH4
Cold junction temperature process value	45			
Cold junction temperature process value (in the Q compatible mode)	29			

■Supported modules

- R60TCTRT2TT2
- R60TCTRT2TT2BW

Memory's PID constants read completion flag

This flag shows whether an operation to the non-volatile memory has been completed without errors or has failed depending on the settings in the following buffer memory area.

- 'CH1 Memory's PID constants read command' (Un\G440) (☞ Page 244 CH1 Memory's PID constants read command)

■Buffer memory address

The following shows the buffer memory address of this area.

Buffer memory area name	CH1	CH2	CH3	CH4
Memory's PID constants read completion flag	46			

■Correspondence between each bit and flag

The following table shows the correspondence between each bit in this buffer memory area and each flag.

Bit No.	Details of flag	Bit No.	Details of flag
b0	CH1 Read completion	b8	CH1 Read failure
b1	CH2 Read completion	b9	CH2 Read failure
b2	CH3 Read completion	b10	CH3 Read failure
b3	CH4 Read completion	b11	CH4 Read failure

■Timing of turning on/off of this flag to 'CH1 Memory's PID constants read command' (Un\G440)

The following figure shows the timing of turning on/off of this flag to 'CH1 Memory's PID constants read command' (Un\G440). (For CH1)

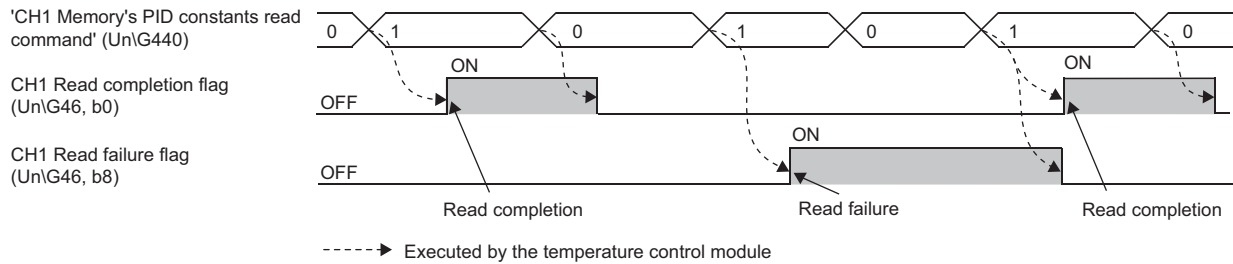

After reading of data from the non-volatile memory has been completed successfully, CH1 Read completion flag (Un\G46, b0) turns off when 'CH1 Memory's PID constants read command' (Un\G440) turns on and off.

After reading of data from the non-volatile memory has been completed successfully, CH1 Read completion flag (Un\G46, b0) turns on.

When reading of data from the non-volatile memory has failed, CH1 Read failure flag (Un\G46, b8) turns on and the temperature control module operates with the PID constants before reading of the data (The LED status remains.).

CH1 Read failure flag (Un\G46, b8) turns off after reading of data in the channel 1 is completed successfully.

When reading of data has failed, turn off and on 'CH1 Memory's PID constants read command' (Un\G440) to read the data again.

Memory's PID constants write completion flag

This flag shows whether an operation to the non-volatile memory has been completed without errors or has failed depending on the settings in the following buffer memory area.

- 'CH1 Automatic backup setting after auto tuning of PID constants' (Un\G547) (Page 281 CH1 Automatic backup setting after auto tuning of PID constants)

For details on the auto tuning function, refer to the following.

Page 35 Auto Tuning Function

■Buffer memory address

The following shows the buffer memory address of this area.

Buffer memory area name	CH1	CH2	CH3	CH4
Memory's PID constants write completion flag	47			

■Correspondence between each bit and flag

The following table shows the correspondence between each bit in this buffer memory area and each flag.

Bit No.	Details of flag	Bit No.	Details of flag
b0	CH1 Write completion	b8	CH1 Write failure
b1	CH2 Write completion	b9	CH2 Write failure
b2	CH3 Write completion	b10	CH3 Write failure
b3	CH4 Write completion	b11	CH4 Write failure

■Timing of turning on/off of this flag to 'CH1 Automatic backup setting after auto tuning of PID constants' (Un\G547).

The following figure shows the timing of turning on/off of this flag to 'CH1 Automatic backup setting after auto tuning of PID constants' (Un\G547). (For CH1)

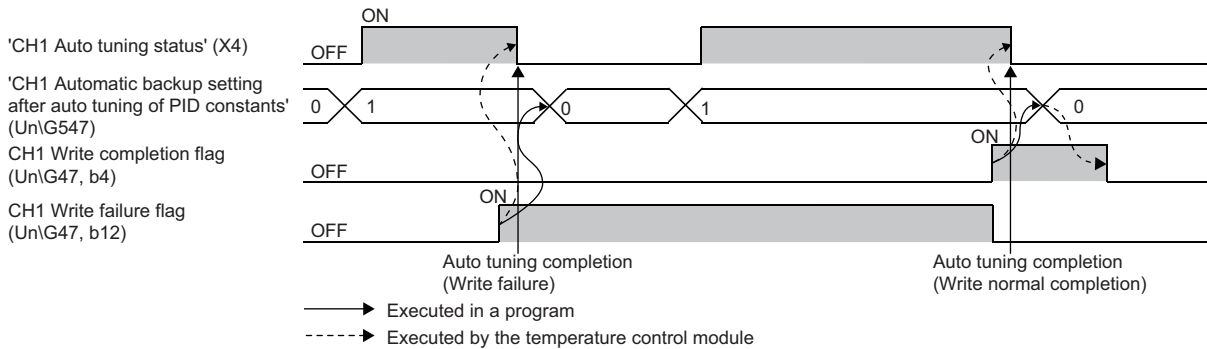

After writing of data to the non-volatile memory has been completed successfully, CH1 Write completion flag (Un\G47, b0) turns on.

CH1 Write completion flag (Un\G47, b0) turns off when the setting of 'CH1 Automatic backup setting after auto tuning of PID constants' (Un\G547) is changed from Enable (1) to Disable (0).

When writing of data to the non-volatile memory has failed, CH1 Write failure flag (Un\G47, b8) turns on and the temperature control module operates with the PID constants calculated in the previous auto tuning (The LED status remains.).

CH1 Write failure flag (Un\G47, b8) turns off after writing of data in the channel 1 is completed successfully.

When writing of data has failed, turn off and on 'CH1 Auto tuning command' (Y4) to execute the auto tuning again. If writing of data fails even after the execution of the auto tuning, a hardware failure has occurred. Please consult your local Mitsubishi representative.

Point

Whether the automatic backup is completed successfully or not can be checked by referring to this flag at the completion of the auto tuning.

A

■Precautions

After checking that one of the following flags is on, set 'CH1 Automatic backup setting after auto tuning of PID constants' (Un\G547) to Disable (0).

- CH1 Write completion flag (Un\G47, b0) (when the automatic backup is completed successfully)
- CH1 Write failure flag (Un\G47, b8) (when the automatic backup fails)

If the auto tuning is executed while 'CH1 Automatic backup setting after auto tuning of PID constants' (Un\G547) is Enable (1), 'CH1 Auto tuning status' (X4) does not turn off even though PID constants are stored after the completion of the auto tuning.

Memory's PID constants read/write completion flag (in Q compatible mode)

In the Q compatible mode, this flag shows whether an operation to the non-volatile memory has been completed without errors or has failed depending on the settings in the following buffer memory area.

- 'CH1 Memory's PID constants read command' (in the Q compatible mode) (Un\G62)
- 'CH1 Memory's PID constants read/write completion flag' (in the Q compatible mode) (Un\G63)

For details on this area, refer to the following. In the Q compatible mode, read the buffer memory addresses for the Q compatible mode.

☞ Page 211 Memory's PID constants read completion flag, Page 212 Memory's PID constants write completion flag

■Buffer memory address

The following shows the buffer memory address of this area.

Buffer memory area name	CH1	CH2	CH3	CH4
Memory's PID constants read/write completion flag (in the Q compatible mode)	31			

■Correspondence between each bit and flag

The following table shows the correspondence between each bit in this buffer memory area and each flag.

Bit No.	Details of flag	Bit No.	Details of flag
b0	CH1 Read completion	b8	CH1 Read failure
b1	CH2 Read completion	b9	CH2 Read failure
b2	CH3 Read completion	b10	CH3 Read failure
b3	CH4 Read completion	b11	CH4 Read failure
b4	CH1 Write completion	b12	CH1 Write failure
b5	CH2 Write completion	b13	CH2 Write failure
b6	CH3 Write completion	b14	CH3 Write failure
b7	CH4 Write completion	b15	CH4 Write failure

Feed forward value memory read completion flag

This flag shows whether reading of data from the following buffer memory areas has been completed successfully or has failed.

- 'CH1 Feed forward value memory read command' (Un\G441)

■Buffer memory address

The following shows the buffer memory address of this area.

Buffer memory area name	CH1	CH2	CH3	CH4
Feed forward value memory read completion flag	48			
Feed forward value memory read completion flag (in the Q compatible mode)	1417			

■Correspondence between each bit and flag

The following table shows the correspondence between each bit in this buffer memory area and each flag.

Bit No.	Details of flag	Bit No.	Details of flag
b0	CH1 Read completion	b8	CH1 Read failure
b1	CH2 Read completion	b9	CH2 Read failure
b2	CH3 Read completion	b10	CH3 Read failure
b3	CH4 Read completion	b11	CH4 Read failure

■Timing of turning on/off of this flag to 'CH1 Feed forward value memory read command' (Un\G441)

The following figure shows the timing of turning on/off of this flag to 'CH1 Feed forward value memory read command' (Un\G441). (For CH1)

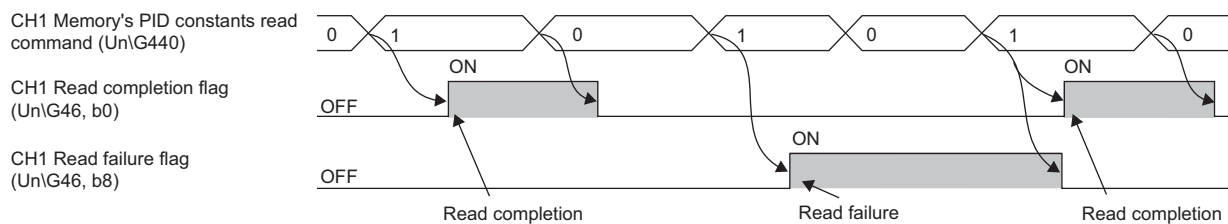

CH1 Read failure flag (Un\G48, b8) turns off after reading of data in the channel 1 is completed successfully.

When reading of data from the memory has failed, CH1 Read failure flag (Un\G48, b8) turns on and the temperature control module operates with the feed forward value before reading of data. (The LED status remains.).

Interrupt factor mask [n]

Set the interrupt factor mask to be used.

Setting value	Setting details
0	Mask (interrupt not used)
1	Clear mask (interrupt used)

Change the setting of 'Interrupt factor mask [n]' (Un\G124 to Un\G139) to Clear mask (interrupt used) (1). When an interrupt factor occurs, an interrupt request is sent to the CPU module. The setting value of 2 or larger is handled as Clear mask (interrupt used) (1).

"n" indicates an interrupt setting number. (n = 1 to 16)

■Buffer memory address

The following shows the buffer memory address of this area.

Buffer memory area name	1	2	3	4	5	6	7	8	9	10	11	12	13	14	15	16
Interrupt factor mask [n]	124	125	126	127	128	129	130	131	132	133	134	135	136	137	138	139
Interrupt factor mask [n] (in the Q compatible mode)	3032	3033	3034	3035	3036	3037	3038	3039	3040	3041	3042	3043	3044	3045	3046	3047

■Default value

The default value is Mask (interrupt not used) (0).

Interrupt factor reset request [n]

An interrupt factor reset request is issued.

Setting value	Setting details
0	No reset request
1	Reset request

When 'Interrupt factor reset request [n]' (Un\G156 to Un\G171) corresponding to a generated interrupt factor has been set to Reset request (1), the interrupt factor corresponding to a specified interrupt is reset. After that, 'Interrupt factor reset request [n]' (Un\G156 to Un\G171) changes to No reset request (0). The setting value of 2 or larger is handled as Reset request (1).

"n" indicates an interrupt setting number. (n = 1 to 16)

■Buffer memory address

The following shows the buffer memory address of this area.

Buffer memory area name	1	2	3	4	5	6	7	8	9	10	11	12	13	14	15	16
Interrupt factor reset request [n]	156	157	158	159	160	161	162	163	164	165	166	167	168	169	170	171
Interrupt factor reset request [n] (in the Q compatible mode)	3064	3065	3066	3067	3068	3069	3070	3071	3072	3073	3074	3075	3076	3077	3078	3079

■Default value

The default value is No reset request (0).

Interrupt factor generation setting [n]

Configure the interrupt request setting for when an interrupt factor occurs while the same interrupt factor has been detected.

Setting value	Setting details
0	Interrupt reissue request
1	No interrupt reissue request

- When 'Interrupt factor generation setting [n]' (Un\G200 to Un\G215) is Interrupt reissue request (0) and an interrupt factor occurs while the same interrupt factor has been detected, an interrupt request is sent to the CPU module again.
- When 'Interrupt factor generation setting [n]' (Un\G200 to Un\G215) is No interrupt reissue request (1) and an interrupt factor occurs while the same interrupt factor has been detected, no interrupt request is sent to the CPU module.
- To send an interrupt request to the CPU module, set 'Interrupt factor reset request [n]' (Un\G156 to Un\G171) to Reset request (1) and 'Interrupt factor detection flag [n]' (Un\G5 to Un\G20) to No interrupt factor (0).

When a value other than the above has been set, an interrupt factor generation setting error (error code: 180△H) occurs.

"n" indicates an interrupt setting number. (n = 1 to 16)

■Buffer memory address

The following shows the buffer memory address of this area.

Buffer memory area name	1	2	3	4	5	6	7	8	9	10	11	12	13	14	15	16
Interrupt factor generation setting [n]	200	201	202	203	204	205	206	207	208	209	210	211	212	213	214	215
Interrupt factor generation setting [n] (in the Q compatible mode)	3096	3097	3098	3099	3100	3101	3102	3103	3104	3105	3106	3107	3108	3109	3110	3111

■Enabling the settings

Turn on and off 'Setting change command' (YB) in the setting mode ('Setting/operation mode status' (X1): Off) to enable the settings.

■Default value

The default value is Interrupt reissue request (0).

Condition target setting [n]

Set the factor to detect interrupts.

Setting value	Setting details
0	Disable
1	Error flag
2	Hardware error flag
3	Temperature rise completion flag
4	Temperature conversion completion flag
5	Alert definition (Input error)
6	Alert definition (Rate alarm)
7	Alert definition (Alert 1)
8	Alert definition (Alert 2)
9	Alert definition (Alert 3)
10	Alert definition (Alert 4)
11	Alert definition (Heater disconnection) (including output off-time current errors)*1
12	Alert definition (Loop disconnection)

*1 The R60TCTRT2TT2BW and R60TCRT4BW only

When a value other than the above has been set, a condition target setting range error (error code: 181△H) occurs.

When an input signal (X) or buffer memory area set in 'Condition target setting [n]' (Un\G232 to Un\G247) turns on, an interrupt request is sent to the CPU module.

"n" indicates an interrupt setting number. (n = 1 to 16)

■Buffer memory address

The following shows the buffer memory address of this area.

Buffer memory area name	1	2	3	4	5	6	7	8	9	10	11	12	13	14	15	16
Condition target setting [n]	232	233	234	235	236	237	238	239	240	241	242	243	244	245	246	247
Condition target setting [n] (in the Q compatible mode)	3128	3129	3130	3131	3132	3133	3134	3135	3136	3137	3138	3139	3140	3141	3142	3143

■Enabling the settings

Turn on and off 'Setting change command' (YB) in the setting mode ('Setting/operation mode status' (X1): Off) to enable the settings.

■Default value

The default value is Disable (0).

Condition target channel setting [n]

Set the channels to detect interrupts.

Setting value	Setting details
0	All channels
1	CH1
2	CH2
3	CH3
4	CH4

When a channel has been specified in 'Condition target setting [n]' (Un\G232 to Un\G247), interrupt factors in the channel set in this area are monitored. When an input signal (X) has been set, the settings in this area are ignored.

When a value other than the above has been set, a condition target channel setting range error (error code: 182△H) occurs. "n" indicates an interrupt setting number. (n = 1 to 16)

■Buffer memory address

The following shows the buffer memory address of this area.

Buffer memory area name	1	2	3	4	5	6	7	8	9	10	11	12	13	14	15	16
Condition target channel setting [n]	264	265	266	267	268	269	270	271	272	273	274	275	276	277	278	279
Condition target channel setting [n] (in the Q compatible mode)	3160	3161	3162	3163	3164	3165	3166	3167	3168	3169	3170	3171	3172	3173	3174	3175

■Enabling the settings

Turn on and off 'Setting change command' (YB) in the setting mode ('Setting/operation mode status' (X1): Off) to enable the settings.

■Default value

The default value is All channels (0).

Control mode selection

Select a control mode. Depending on this setting, the control method of each channel changes as follows.

Setting value	Control mode	No. of control loops	No. of channels for temperature input
0	Standard control	Standard control 4 loops	—
1	Heating-cooling control (normal mode)	Heating-cooling control 2 loops	2
2	Heating-cooling control (expanded mode)	Heating-cooling control 4 loops	—
3	Mix control (normal mode)	<ul style="list-style-type: none"> • Heating-cooling control 1 loops • Standard control 2 loops 	1
4	Mix control (expanded mode)	<ul style="list-style-type: none"> • Heating-cooling control 2 loops • Standard control 2 loops 	—
5	Position-proportional control (normal mode)	Position-proportional control 2 loops	2
6	Position-proportional control (expanded mode)	Position-proportional control 4 loops	—

Point

- When the control mode has been changed, all items are overwritten with default values. Change each parameter setting if necessary.
- A set value discrepancy error (control mode) (error code: 1910H) occurs right after the control mode change. To clear the error, turn off and on 'Setting value backup command' (Y8) and register the parameter after the change in the non-volatile memory.

■Buffer memory address

The following shows the buffer memory address of this area.

Buffer memory area name	CH1	CH2	CH3	CH4
Control mode selection	300			
Control mode selection (in the Q compatible mode)	1025			

■Default value

The default value is Standard control (0).

Sampling cycle selection

Select one of the following sampling cycles.

- 0: 500ms/4 channels
- 1: 250ms/4 channels

■Buffer memory address

The following shows the buffer memory address of this area.

Buffer memory area name	CH1	CH2	CH3	CH4
Sampling cycle selection	301			

■Default value

The default value is 500ms/4 channels (0).

Point

- A set value discrepancy error (sampling cycle) (error code: 1930H) occurs right after the sampling cycle change. To clear the error, turn off and on 'Setting value backup command' (Y8) and register the parameter after the change in the non-volatile memory.

Automatic setting at input range change

When the setting of 'CH1 Input range' (Un\G501) was changed, this function automatically changes data in the related buffer memory areas to prevent the occurrence of a set value discrepancy error (error code: 1950H).

- 0: Disable
- 1: Enable

When Enable (1) has been set, the following buffer memory areas are automatically set or initialized when the setting of 'CH1 Input range' (Un\G501) is changed.

Buffer memory area name	Buffer memory address	Value after change
CH1 Set value (SV) setting	430	0
CH1 Proportional band (P) setting	431	30
CH1 Alert set value 1 to CH1 Alert set value 4	434 to 437	0
CH1 Cooling proportional band (Pc) setting	439	30
CH1 Upper limit setting limiter	511	Upper limit value of the input range
CH1 Lower limit setting limiter	512	Lower limit value of the input range
CH1 Setting variation rate limiter/setting variation rate limiter (temperature rise)	513	0
CH1 Setting variation rate limiter (temperature drop)	514	0
CH1 Adjustment sensitivity (dead band) setting	516	5
CH1 Overlap/dead band setting	524	0
CH1 Alert dead band setting	531	5
CH1 Loop disconnection detection dead band	538	0
CH1 AT bias	546	0
CH1 Simultaneous temperature rise gradient data	554	0
CH1 Simultaneous temperature rise dead time	555	0
CH1 Disturbance judgment position	557	0
CH1 Sensor correction value setting	565	0
CH1 Sensor two-point correction offset value (measured value)	568	0
CH1 Sensor two-point correction offset value (corrected value)	569	0
CH1 Sensor two-point correction gain value (measured value)	570	0
CH1 Sensor two-point correction gain value (corrected value)	571	0

■Buffer memory address

The following shows the buffer memory address of this area.

Buffer memory area name	CH1	CH2	CH3	CH4
Automatic setting at input range change	302			

■Default value

The default value is Disable (0).

Setting variation rate limiter setting selection

When setting the variation amount of the set value (SV), select whether to set the variation amount limiter setting values in a batch or individually at the temperature rise or temperature drop.

- 0: Set in a batch at temperature rise/temperature drop
- 1: Individually set at temperature rise/temperature drop

■Buffer memory address

The following shows the buffer memory address of this area.

Buffer memory area name	CH1	CH2	CH3	CH4
Setting variation rate limiter setting selection	303			

■Default value

The default value is Set in a batch at temperature rise/temperature drop (0).

Control output cycle unit selection setting

Select 0.1s or 1s as the unit of the transistor output ON/OFF cycle.

- 0: 1s cycle
- 1: 0.1s cycle

■Buffer memory address

The following shows the buffer memory address of this area.

Buffer memory area name	CH1	CH2	CH3	CH4
Control output cycle unit selection setting	304			

■Default value

The default value is 1s cycle (0).

Point

When the control output cycle unit has been changed, the control output cycle setting, heating control output cycle setting, and cooling control output cycle setting are overwritten with their default values. A set value discrepancy error (control output cycle unit selection setting) (error code: 1920H) occurs right after the control output cycle unit selection setting change. To clear the error, turn off and on 'Setting value backup command' (Y8) and register the parameter after the change in the non-volatile memory.

Moving average processing setting

Set whether to enable or disable the moving average processing.

- 0: Enable
- 1: Disable

■Buffer memory address

The following shows the buffer memory address of this area.

Buffer memory area name	CH1	CH2	CH3	CH4
Moving average processing setting	305			



■Default value

The default value is 0.

PID continuation flag

Set the operation status at the time when the mode has shifted from the operation mode to the setting mode (when 'Setting/operation mode command' (Y1) is turned on and off).

For details on the relation between the setting of this flag and the control status, refer to the following.

- PID control ( Page 20 Condition to execute the PID control)
- Temperature judgment ( Page 224 CH1 Alert definition)
- Alert judgment ( Page 76 Condition for alert judgment)

■Buffer memory address

The following shows the buffer memory address of this area.

Buffer memory area name	CH1	CH2	CH3	CH4
PID continuation flag	306			
PID continuation flag (in the Q compatible mode)	169			

■Setting range

- 0: Stop
- 1: Continue

■Default value

The default value is Stop (0).

Transistor output monitor ON delay time setting

Set the delay time of ON delay output flag. Configure this setting to detect heater disconnections with another input module on the system.

For ON delay output flag, refer to the following.

☞ Page 228 CH1 Transistor output flag

For details on the ON delay output function, refer to the following.

☞ Page 67 ON Delay Output Function

■Buffer memory address

The following shows the buffer memory address of this area.

Buffer memory area name	CH1	CH2	CH3	CH4
Transistor output monitor ON delay time setting	307			
Transistor output monitor ON delay time setting (in the Q compatible mode)	175			

■Setting range

The setting range is 0 or 1 to 50 (10 to 500ms). When 0 has been set, ON delay output flag is not set to 1 (ON).

■Default value

The default value is 0.

Manipulated value resolution change for output with another analog module

Set the resolutions of the following buffer memory areas.

- 'CH1 Manipulated value (MV)' (Un\G403)
- 'CH1 Manipulated value for heating (MVh)' (Un\G403)
- 'CH1 Manipulated value for cooling (MVc)' (Un\G408)

For details, refer to the following.

☞ Page 68 Output

■Buffer memory address

The following shows the buffer memory address of this area.

Buffer memory area name	CH1	CH2	CH3	CH4
Manipulated value resolution change for output with another analog module	308			
Manipulated value resolution change for output with another analog module (in the Q compatible mode)	181			

■Setting range

- 0: 0 to 4000
- 1: 0 to 12000
- 2: 0 to 16000
- 3: 0 to 20000
- 4: 0 to 32000

The manipulated values (MV) to which the resolutions have been reflected are stored in the following buffer memory areas.

- 'CH1 Manipulated value (MV) for output with another analog module' (Un\G407)
- 'CH1 Manipulated value for heating (MVh) for output with another analog module' (Un\G407)
- 'CH1 Manipulated value for cooling (MVc) for output with another analog module' (Un\G409)

■Enabling the settings

Turn on and off 'Setting change command' (YB) in the setting mode ('Setting/operation mode status' (X1): Off) to enable the settings.

■Default value

The default value is 0 to 4000 (0).

Cold junction temperature compensation selection

Select whether to execute the cold junction temperature compensation with standard terminal blocks, terminal block converter module for temperature control, or not to execute the cold junction temperature compensation.

■Buffer memory address

The following shows the buffer memory address of this area.

Buffer memory area name	CH1	CH2	CH3	CH4
Cold junction temperature compensation selection	309			
Cold junction temperature compensation selection (in the Q compatible mode)	182			

■Settable modules

- R60TCTRT2TT2
- R60TCTRT2TT2BW

■Setting range

- 0: Use standard terminal block
- 1: Use terminal block converter module for temperature control
- 2: Do not use cold junction temperature compensation

■Default value

The default value is Use standard terminal block (0).

CH1 Decimal point position

Depending on the setting of 'CH1 Input range' (Un\G501), the decimal point position applicable in the following buffer memory areas is stored in this area.

- 'CH1 Temperature process value (PV)' (Un\G402)
- 'CH1 Set value (SV) setting' (Un\G430)
- 'CH1 Proportional band (P) setting' (Un\G431) (in the R mode)
- 'CH1 Alert set value 1' (Un\G434)
- 'CH1 Alert set value 2' (Un\G435)
- 'CH1 Alert set value 3' (Un\G436)
- 'CH1 Alert set value 4' (Un\G437)
- 'CH1 Cooling proportional band (Pc) setting' (Un\G439) (in the R mode)
- 'CH1 Upper limit setting limiter' (Un\G511)
- 'CH1 Lower limit setting limiter' (Un\G512)
- 'CH1 Setting variation rate limiter/setting variation rate limiter (temperature rise)' (Un\G513) (in the R mode)
- 'CH1 Setting variation rate limiter (temperature drop)' (Un\G514) (in the R mode)
- 'CH1 Adjustment sensitivity (dead band) setting' (Un\G516) (in the R mode)
- 'CH1 Overlap/dead band setting' (Un\G524) (in the R mode)
- 'CH1 Alert dead band setting' (Un\G531) (in the R mode)
- 'CH1 Loop disconnection detection dead band' (Un\G538)
- 'CH1 Rate alarm upper limit value' (Un\G541)
- 'CH1 Rate alarm lower limit value' (Un\G542)
- 'CH1 AT bias' (Un\G546)
- 'CH1 Simultaneous temperature rise gradient data' (Un\G554)
- 'CH1 Disturbance judgment position' (Un\G557)
- 'CH1 Sensor correction value setting' (Un\G565) (in the R mode)
- 'CH1 Sensor two-point correction offset value (measured value)' (Un\G568)
- 'CH1 Sensor two-point correction offset value (corrected value)' (Un\G569)
- 'CH1 Sensor two-point correction gain value (measured value)' (Un\G570)
- 'CH1 Sensor two-point correction gain value (corrected value)' (Un\G571)

Stored values differ depending on the setting in 'CH1 Input range' (Un\G501).

'CH1 Input range' (Un\G501)	Stored value	Setting details
Resolution: 1	0	No decimal point
Resolution: 0.1	1	First decimal place

■ Buffer memory address

The following shows the buffer memory address of this area.

Buffer memory area name	CH1	CH2	CH3	CH4
CH□ Decimal point position	400	600	800	1000
CH□ Decimal point position (in the Q compatible mode)	1	2	3	4

CH1 Alert definition

Bits corresponding to alerts detected become 1.

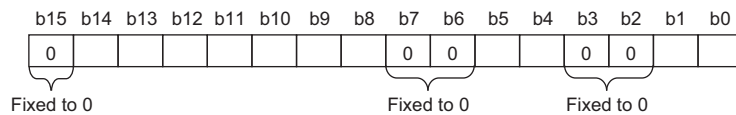

Bit No.	Flag name	Alert definition
b0	CH1 Input range upper limit	When the temperature process value (PV) has exceeded the temperature measuring range*1 of the set input range
b1	CH1 Input range lower limit	When the temperature process value (PV) has fallen below the temperature measuring range*1 of the set input range
b2, b3	— (Fixed to 0)	— (Not used)
b4	CH1 Rate alarm upper limit	When the variation amount of the temperature process value (PV) is equal to or larger than the rate alarm upper limit value
b5	CH1 Rate alarm lower limit	When the variation amount of the temperature process value (PV) is equal to or smaller than the rate alarm lower limit value
b6, b7	— (Fixed to 0)	— (Not used)
b8	CH1 Alert 1	When Alert 1 has occurred (☞ Page 69 Alert Function)
b9	CH1 Alert 2	When Alert 2 has occurred (☞ Page 69 Alert Function)
b10	CH1 Alert 3	When Alert 3 has occurred (☞ Page 69 Alert Function)
b11	CH1 Alert 4	When Alert 4 has occurred (☞ Page 69 Alert Function)
b12	CH1 Heater disconnection detection	When a heater disconnection has been detected (☞ Page 83 Heater Disconnection Detection Function)
b13	CH1 Loop disconnection detection	When a loop disconnection has been detected (☞ Page 88 Loop Disconnection Detection Function)
b14	CH1 Output off-time current error	When an output off-time current error has been detected (☞ Page 87 Output Off-time Current Error Detection Function)
b15	— (Fixed to 0)	— (Not used)

*1 The range between the input range lower limit value - 5% and the input range upper limit value + 5% for the full scale of the input range

■ Buffer memory address

The following shows the buffer memory address of this area.

Buffer memory area name	CH1	CH2	CH3	CH4
CH□ Alert definition	401	601	801	1001
CH□ Alert definition (in the Q compatible mode)	5	6	7	8

■ Temperature measuring range

The following shows a calculation example of the temperature measuring range.

Ex.

Calculation example: When 'CH1 Input range' (Un\G501) is 38

- (Input range lower limit value) - (5% of full scale) = $-200 - ((400.0 - (-200.0)) \times 0.05) = -230.0$
- (Input range upper limit value) + (5% of full scale) = $400 + ((400.0 - (-200.0)) \times 0.05) = 430.0$

Therefore, the temperature measuring range is -230.0°C to 430.0°C.

The temperature control module checks whether an input temperature is within the temperature measuring range of the input range. When the input temperature is out of the temperature measuring range, CH1 Input range upper limit (Un\G401, b0) or CH1 Input range lower limit (Un\G401, b1) becomes 1 (ON). The conditions that the temperature control module uses to judge whether the measured temperature is within the temperature measuring range or not differ depending on the following settings.

- 'Setting/operation mode command' (Y1) (☞ Page 158 Setting/operation mode command)
- 'PID continuation flag' (Un\G306) (☞ Page 220 PID continuation flag)
- 'CH1 PID control forced stop command' (YC) (☞ Page 160 PID control forced stop command)
- 'CH1 Stop mode setting' (Un\G503) (☞ Page 252 CH1 Stop mode setting)

■Conditions to execute/not to execute the temperature judgment

The following table lists the conditions used to determine whether to execute the temperature judgment.

Executed: ○, Not executed: ×

'Setting/operation mode command' (Y1)	'PID continuation flag' (Un\G306)	'CH1 PID control forced stop command' (YC)	'CH1 Stop mode setting' (Un\G503)	Temperature judgment	
Setting mode at power-on	Stop (0), Continue (1)	Off, On	Stop (0)	×	
			Monitor (1)	○	
			Alert (2)	○	
Operation mode (during operation)	Stop (0), Continue (1)	OFF	Stop (0), Monitor (1), Alert (2)	○	
		ON	Stop (0)	×	
			Monitor (1)	○	
			Alert (2)	○	
			Alert (2)	○	
		Setting mode (after operation)	Stop (0)	Off, On	Stop (0)
Monitor (1)	○				
Alert (2)	○				
Continue (1)	OFF		Stop (0), Monitor (1), Alert (2)	○	
			ON	Stop (0)	×
				Monitor (1)	○
			Alert (2)	○	

*1 For each timing, refer to the following.

 Page 158 Setting/operation mode command

When 'CH1 Unused channel setting' (Un\G502) has been set to Unused (1), the temperature judgment is not executed even though the above conditions have been satisfied. ( Page 251 CH1 Unused channel setting)

CH1 Temperature process value (PV)

A detected temperature value to which the sensor correction has been executed is stored in this area.

The value to be stored differs depending on the value stored in 'CH1 Decimal point position' (Un\G400). ( Page 223 CH1 Decimal point position)

- When 'CH1 Decimal point position' (Un\G400) is No decimal point (0): A detected temperature value is stored as it is.
- When 'CH1 Decimal point position' (Un\G400) is First decimal place (1): A detected temperature value is stored after being multiplied by 10.

Point

When a value measured by a temperature sensor has exceeded the temperature measuring range, the following value is stored.

- When the measured value is larger than the upper limit value of the temperature measuring range: Input range upper limit value + 5% of full scale
- When the measured value is smaller than the lower limit value of the temperature measuring range: Input range lower limit value - 5% of full scale

■Buffer memory address

The following shows the buffer memory address of this area.

Buffer memory area name	CH1	CH2	CH3	CH4
CH□ Temperature process value (PV)	402	602	802	1002
CH□ Temperature process value (PV) (in the Q compatible mode)	9	10	11	12

CH1 Manipulated value (MV)

Results of the PID operation executed on the basis of the temperature process value (PV) are stored in these areas. The following table lists the range of values to be stored.

Stored contents	Range of values to be stored during control	Value to be stored while the control has stopped
Manipulated value (MV)	-50 to 1050 (-5% to 105.0%)	-50 (-5.0%)
Manipulated value for heating (MVh)	0 to 1050 (0.0% to 105.0%)	-50 (-5.0%)
Manipulated value for cooling (MVC)		

However, values are output within the range of 0 to 100%. For values smaller than 0% and larger than 100%, refer to the following.

- Values smaller than 0%: 0%
- Values larger than 100%: 100%

■Buffer memory address

The following shows the buffer memory address of this area.

Buffer memory area name	CH1	CH2	CH3	CH4
CH□ Manipulated value (MV)	403	603	803	1003
CH□ Manipulated value (MV) (in the Q compatible mode)	13	14	15	16

■Manipulated value (MV) and control output cycle

- A manipulated value (MV) is the ON time of 'CH1 Control output cycle setting' (Un\G504) displayed in percentage. (☞ Page 253 CH1 Control output cycle setting)
- A manipulated value for heating (MVh) is the ON time of 'CH1 Heating control output cycle setting' (Un\G504) displayed in percentage. (☞ Page 254 CH1 Heating control output cycle setting)
- A manipulated value for cooling (MVC) is the ON time of 'CH1 Cooling control output cycle setting' (Un\G522) displayed in percentage. (☞ Page 266 CH1 Cooling control output cycle setting)

Ex.

When 600 (60.0%) has been stored in 'CH1 Manipulated value (MV)' (Un\G403) and the value in the following buffer memory area has been set as follows

- 'CH1 Control output cycle setting' (Un\G504): 30s

ON time of transistor output = Control output cycle setting (s) × Manipulated value (MV) (%) = 30 × 0.6 = 18 (s)

ON time of the transistor output is 18s.

Transistor output becomes the pulse that is on for 18s and off for 12s.

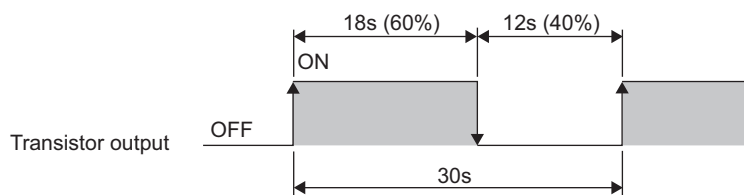

CH1 Manipulated value for heating (MVh)

For details on this area, refer to the following.

☞ Page 226 CH1 Manipulated value (MV)

■Buffer memory address

The following shows the buffer memory address of this area.

Buffer memory area name	CH1	CH2	CH3	CH4
CH□ Manipulated value for heating (MVh)	403	603	803	1003
CH□ Manipulated value for heating (MVh) (in the Q compatible mode)	13	14	15	16

CH1 Manipulated value for cooling (MVC)

For details on this area, refer to the following.

☞ Page 226 CH1 Manipulated value (MV)

■Buffer memory address

The following shows the buffer memory address of this area.

Buffer memory area name	CH1	CH2	CH3	CH4
CH□ Manipulated value for cooling (MVC)	408	608	808	1008
CH□ Manipulated value for cooling (MVC) (in the Q compatible mode)	704	705	706	707

CH1 Temperature rise judgment flag

This flag is for checking whether the temperature process value (PV) is within the temperature rise completion range or not.

One of the following values is stored in this area.

- 0: Out of the temperature rise completion range
- 1: Within the temperature rise completion range

When the temperature process value (PV) stays within the temperature rise completion range during the set temperature rise completion soak time, Within temperature rise completion range (1) is stored in this buffer memory area.

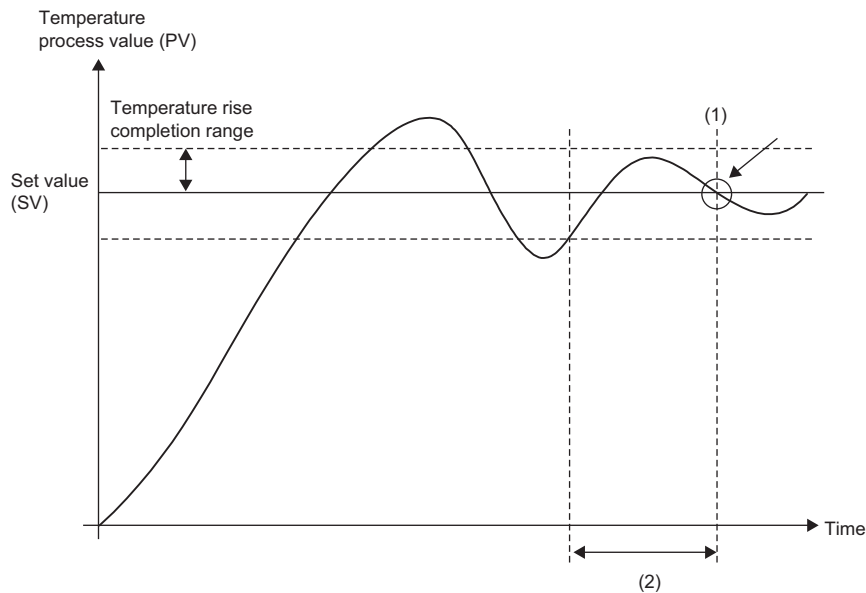

(1) At this time, 'CH1 Temperature rise judgment flag' (Un\G404) is set to Within temperature rise completion range (1).

(2) 'CH1 Temperature rise completion soak time setting' (Un\G507)

Set the temperature rise completion range and the temperature rise completion soak time in the following buffer memory areas.

- 'CH1 Temperature rise completion range setting' (Un\G506) (☞ Page 255 CH1 Temperature rise completion range setting)
- 'CH1 Temperature rise completion soak time setting' (Un\G507) (☞ Page 255 CH1 Temperature rise completion soak time setting)

■Buffer memory address

The following shows the buffer memory address of this area.

Buffer memory area name	CH1	CH2	CH3	CH4
CH□ Temperature rise judgment flag	404	604	804	1004
CH□ Temperature rise judgment flag (in the Q compatible mode)	17	18	19	20

CH1 Transistor output flag

The on/off states of the transistor output and ON delay output are stored in this buffer memory area.

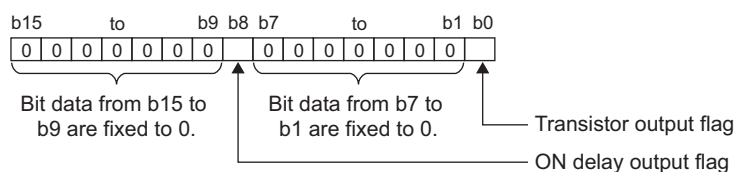

■Buffer memory address

The following shows the buffer memory address of this area.

Buffer memory area name	CH1	CH2	CH3	CH4
CH□ Transistor output flag	405	605	805	1005
CH□ Transistor output flag (in the Q compatible mode)	21	22	23	24

■Relation with ON delay output flag

The following figure shows the relation between Transistor output flag and ON delay output flag.

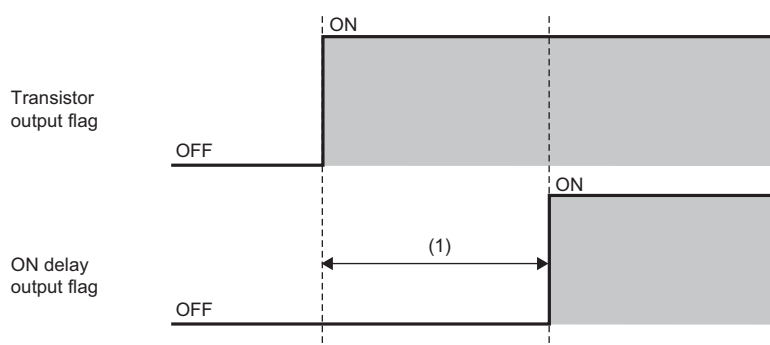

(1) 'Transistor output monitor ON delay time setting' (Un\G307)

'Transistor output monitor ON delay time setting' (Un\G307) allows users to configure the setting considering the delay time (response delay/scan time delay) of actual transistor outputs. (☞ Page 221 Transistor output monitor ON delay time setting)

This flag can be used for the program that judges a disconnection of transistor output by monitoring ON delay output flag and inputs from external sensors.

For details on the ON delay output function, refer to the following.

☞ Page 67 ON Delay Output Function

CH1 Heating transistor output flag

For details on this area, refer to the following.

☞ Page 228 CH1 Transistor output flag

■Buffer memory address

The following shows the buffer memory address of this area.

Buffer memory area name	CH1	CH2	CH3	CH4
CH□ Heating transistor output flag	405	605	805	1005
CH□ Heating transistor output flag (in the Q compatible mode)	21	22	23	24

*1 In GX Works3, CH□ Transistor output flag is displayed as the sample comment of CH□ Heating transistor output flag.

CH1 Open side transistor output flag

For details on this area, refer to the following.

 Page 228 CH1 Transistor output flag

■Buffer memory address

The following shows the buffer memory address of this area.

Buffer memory area name	CH1	CH2	CH3	CH4
CH□ Open side transistor output flag	405	605	805	1005
CH□ Open side transistor output flag (in the Q compatible mode)	21	22	23	24

*1 In GX Works3, CH□ Transistor output flag is displayed as the sample comment of CH□ Open side transistor output flag.

CH1 Set value (SV) monitor

The set value (SV) of each unit time set in 'CH1 Setting variation rate limiter unit time setting' (Un\G526) is stored in this buffer memory area. ( Page 268 CH1 Setting variation rate limiter unit time setting)

The set value (SV) can be monitored in real time.

■Buffer memory address

The following shows the buffer memory address of this area.

Buffer memory area name	CH1	CH2	CH3	CH4
CH□ Set value (SV) monitor	406	606	806	1006
CH□ Set value (SV) monitor (in the Q compatible mode)	25	26	27	28

CH1 Manipulated value (MV) for output with another analog module

The values stored in the following buffer memory areas are converted for other analog modules on the system (such as a D/A converter module) and stored in this buffer memory area.

Buffer memory area name	Buffer memory address	Reference
CH1 Manipulated value (MV)	403	Page 226 CH1 Manipulated value (MV)

The range of the values to be stored differs depending on the resolution set in the following buffer memory area. (0 to 4000, 0 to 12000, 0 to 16000, 0 to 20000, 10 to 32000)

- 'Manipulated value resolution change for output with another analog module' (Un\G308) ( Page 221 Manipulated value resolution change for output with another analog module)

Point

When the device that executes heating or cooling can receive only analog inputs, use other analog modules (such as a D/A converter module) to convert digital inputs to analog output values.

■Buffer memory address

The following shows the buffer memory address of this area.

Buffer memory area name	CH1	CH2	CH3	CH4
CH□ Manipulated value (MV) for output with another analog module	407	607	807	1007
CH□ Manipulated value (MV) for output with another analog module (in the Q compatible mode)	177	178	179	180

CH1 Manipulated value for heating (MVh) for output with another analog module

The values stored in the following buffer memory areas are converted for other analog modules on the system (such as a D/A converter module) and stored in this buffer memory area.

Buffer memory area name	Buffer memory address	Reference
CH1 Manipulated value for heating (MVh)	403	Page 226 CH1 Manipulated value for heating (MVh)

For details on this area, refer to the following.

☞ Page 229 CH1 Manipulated value (MV) for output with another analog module

■ Buffer memory address

The following shows the buffer memory address of this area.

Buffer memory area name	CH1	CH2	CH3	CH4
CH□ Manipulated value for heating (MVh) for output with another analog module	407	607	807	1007
CH□ Manipulated value for heating (MVh) for output with another analog module (in the Q compatible mode)	177	178	179	180

CH1 Manipulated value for cooling (MVc) for output with another analog module

The values stored in the following buffer memory areas are converted for other analog modules on the system (such as a D/A converter module) and stored in this buffer memory area.

Buffer memory area name	Buffer memory address	Reference
CH1 Manipulated value for cooling (MVc)	408	Page 227 CH1 Manipulated value for cooling (MVc)

For details on this area, refer to the following.

☞ Page 229 CH1 Manipulated value (MV) for output with another analog module

■ Buffer memory address

The following shows the buffer memory address of this area.

Buffer memory area name	CH1	CH2	CH3	CH4
CH□ Manipulated value for cooling (MVc) for output with another analog module	409	609	809	1009
CH□ Manipulated value for cooling (MVc) for output with another analog module (in the Q compatible mode)	708	709	710	711

CH1 Cooling transistor output flag

For details on this area, refer to the following.

☞ Page 228 CH1 Transistor output flag

■ Buffer memory address

The following shows the buffer memory address of this area.

Buffer memory area name	CH1	CH2	CH3	CH4
CH□ Cooling transistor output flag	410	610	810	1010
CH□ Cooling transistor output flag (in the Q compatible mode)	712	713	714	715

CH1 Close side transistor output flag

For details on this area, refer to the following.

☞ Page 228 CH1 Transistor output flag

■ Buffer memory address

The following shows the buffer memory address of this area.

Buffer memory area name	CH1	CH2	CH3	CH4
CH□ Close side transistor output flag	410	610	810	1010
CH□ Close side transistor output flag (in the Q compatible mode)	712	713	714	715

*1 In GX Works3, CH□ Cooling transistor output flag is displayed as the sample comment of CH□ Close side transistor output flag.

CH1 Self-tuning flag

The execution status of the self-tuning can be monitored in this area. For details on the self-tuning function, refer to the following.

☞ Page 44 Self-tuning Function

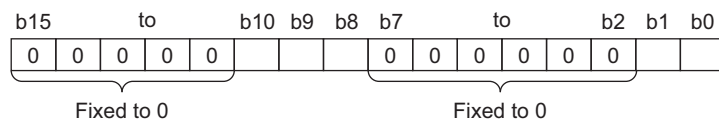

One of the following values is stored in each bit.

- 0: Off
- 1: On

Bit	Flag name	Description	Condition in which the bit turns off
b0	PID auto-correction status	This bit turns on after PID constants are corrected by the self-tuning.	This bit turns off after one of the following operations is executed.
b1	Simultaneous temperature rise parameter correction status	This bit turns on after the simultaneous temperature rise parameters ^{*1} are corrected by the self-tuning.	<ul style="list-style-type: none"> • When 'Setting/operation mode command' (Y1) is turned on and off and the mode shifts to the setting mode • When 'CH1 Unused channel setting' (Un\G502) is set to Unused (1) • When 'CH1 PID control forced stop command' (YC) is turned off and on • When 'CH1 Self-tuning setting' (Un\G548) is set to Do not execute ST (0) This bit turns off in the following cases as well. <ul style="list-style-type: none"> • When the self-tuning has started by the change of the set value (SV) • When the temperature process value (PV) becomes out of the stable state and the vibration ST has started
b2 to b7	— (Fixed to 0)	— (Not used)	—
b8	Self-tuning disable status	This bit turns on when the self-tuning was not able to be executed.	This bit turns off after one of the following operations is executed. <ul style="list-style-type: none"> • When 'Setting/operation mode command' (Y1) is turned on and off and the mode shifts to the setting mode • When 'CH1 Unused channel setting' (Un\G502) is set to Unused (1) • When 'CH1 PID control forced stop command' (YC) is turned off and on • When 'CH1 Self-tuning setting' (Un\G548) is set to Do not execute ST (0) This bit turns off when all the conditions that disable the execution of the self-tuning are cleared. For conditions that disable the execution of the self-tuning, refer to the following. ☞ Page 48 Conditions in which the self-tuning is not executed

Bit	Flag name	Description	Condition in which the bit turns off
b9	Simultaneous temperature rise parameter error status	This bit turns on when the simultaneous temperature rise parameters ^{*1} cannot be calculated by the self-tuning.	This bit turns off after one of the following operations is executed. <ul style="list-style-type: none"> When 'Setting/operation mode command' (Y1) is turned on and off and the mode shifts to the setting mode When 'CH1 Unused channel setting' (Un\G502) is set to Unused (1) When 'CH1 PID control forced stop command' (YC) is turned off and on When 'CH1 Self-tuning setting' (Un\G548) is set to Do not execute ST (0)
b10	Self-tuning error	<p>This bit turns on after one of the following operations is executed during the self-tuning.^{*2}</p> <ul style="list-style-type: none"> Changing the set value (SV) setting (only during the start-up) Changing PID constants Changing the setting variation rate limiter Changing the output limiter Changing the output variation limiter setting Changing the control output cycle Changing the sensor correction Changing the primary delay digital filter Shifting AUTO→MAN mode Switching direct/reverse action <p>This bit also turns on in the following cases.</p> <ul style="list-style-type: none"> When 6000 seconds (1 hour and 40 minutes) or longer have passed after the self-tuning was started When the variation speed of the temperature process value (PV) is slower than 1.125 (°C/min) during the self-tuning When the temperature process value (PV) becomes out of the temperature measuring range When required measurement data was not obtained because the manipulated value (MV) did not reach the upper limit output limiter value or the lower limit output limiter value before the completion of the measurement When the temperature process value (PV) that was supposed to increase after the self-tuning was started with the starting ST, and decreased by 1°C (°F) or more instead When the temperature process value (PV) that was supposed to decrease after the self-tuning was started with the starting ST, and increased by 1°C (°F) or more instead 	<p>This bit turns off in the following cases as well.</p> <ul style="list-style-type: none"> When the self-tuning has started by the change of the set value (SV) When the temperature process value (PV) becomes out of the stable state and the vibration ST has started
b11 to b15	— (Fixed to 0)	— (Not used)	—

*1 The values of 'CH1 Simultaneous temperature rise gradient data' (Un\G554) and 'CH1 Simultaneous temperature rise dead time' (Un\G555) (Page 287 CH1 Simultaneous temperature rise gradient data, Page 287 CH1 Simultaneous temperature rise dead time)

*2 When this bit turns on under any condition other than the ones described above, check the contents of the following table according to the setting of 'CH1 Self-tuning setting' (Un\G548).

Setting details	Check contents
1: Starting ST (Only PID constants are calculated.)	<ul style="list-style-type: none"> Check if wiring is correct in control loop. Set 'CH1 Self-tuning setting' (Un\G548) to "4: Starting ST + vibration ST (Only PID constants are calculated for both.)" and execute the control.
3: Starting ST (PID constants and simultaneous temperature rise parameters are calculated.)	<ul style="list-style-type: none"> Check if wiring is correct in control loop. When the simultaneous temperature rise parameters have been calculated, save the calculated parameters. After that, set 'CH1 Self-tuning setting' (Un\G548) to "4: Starting ST + Vibration ST (Only PID constants are calculated for both.)" and execute the control. When the simultaneous temperature rise parameters have not been calculated, check if wiring is correct in control loop.

■ Buffer memory address

The following shows the buffer memory address of this area.

Buffer memory area name	CH1	CH2	CH3	CH4
CH□ Self-tuning flag	411	611	811	1011
CH□ Self-tuning flag (in the Q compatible mode)	575	607	639	671

Point

This area is enabled only for the following channels.

- CH1 to CH4 of when the standard control is used
- CH3 and CH4 of when the mix control (normal mode) or mix control (expanded mode) is used

CH1 Process value (PV) scaling value

When the temperature process value (PV) scaling function is enabled, a scaled temperature process value (PV) is stored. For details on the temperature process value (PV) scaling function, refer to the following.

☞ Page 65 Scaling Function

■ Buffer memory address

The following shows the buffer memory address of this area.

Buffer memory area name	CH1	CH2	CH3	CH4
CH□ Process value (PV) scaling value	412	612	812	1012
CH□ Process value (PV) scaling value (in the Q compatible mode)	728	744	760	776

CH1 AT simultaneous temperature rise parameter calculation flag

The status of when the simultaneous temperature rise AT (auto tuning) calculates the simultaneous temperature rise parameter is stored in this area.

- 0: Off
- 1: On

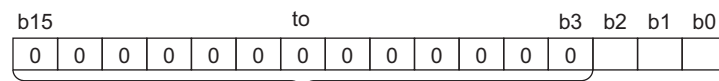

Bit data from b15 to b3 are fixed to 0.

Bit	Flag name	Description
b0	AT simultaneous temperature rise parameter calculation completion	This bit turns on when the simultaneous temperature rise parameters*1 are calculated by the simultaneous temperature rise AT.
b1	AT simultaneous temperature rise parameter calculation error status	This bit turns on when the simultaneous temperature rise parameters*1 cannot be calculated by the simultaneous temperature rise AT.
b2	Simultaneous temperature rise AT disable status	This bit turns on when the simultaneous temperature rise AT was not able to be executed.
b3 to b15	— (Fixed to 0)	— (Not used)

*1 The values of 'CH1 Simultaneous temperature rise gradient data' (UnG554) and 'CH1 Simultaneous temperature rise dead time' (UnG555)

A

Point

This area is enabled only for the following channels.

- CH1 to CH4 of when the standard control is used
- CH3 and CH4 of when the mix control (normal mode) or mix control (expanded mode) is used

For details on the simultaneous temperature rise function, refer to the following.

☞ Page 97 Simultaneous Temperature Rise Function

■ Buffer memory address

The following shows the buffer memory address of this area.

Buffer memory area name	CH1	CH2	CH3	CH4
CH□ AT simultaneous temperature rise parameter calculation flag	413	613	813	1013
CH□ AT simultaneous temperature rise parameter calculation flag (in the Q compatible mode)	573	605	637	669

CH1 Simultaneous temperature rise status

The execution status of the simultaneous temperature rise can be monitored in this area.

- 0: Simultaneous temperature rise not in process
- 1: Simultaneous temperature rise in process

During control by the simultaneous temperature rise function, Simultaneous temperature rise in process (1) is stored in this area.

The following figure shows the timing on when Simultaneous temperature rise not in process (0) is stored in this area. In the figure, CH1 and CH2 have been set to Group 1. (☞ Page 285 CH1 Simultaneous temperature rise group setting)

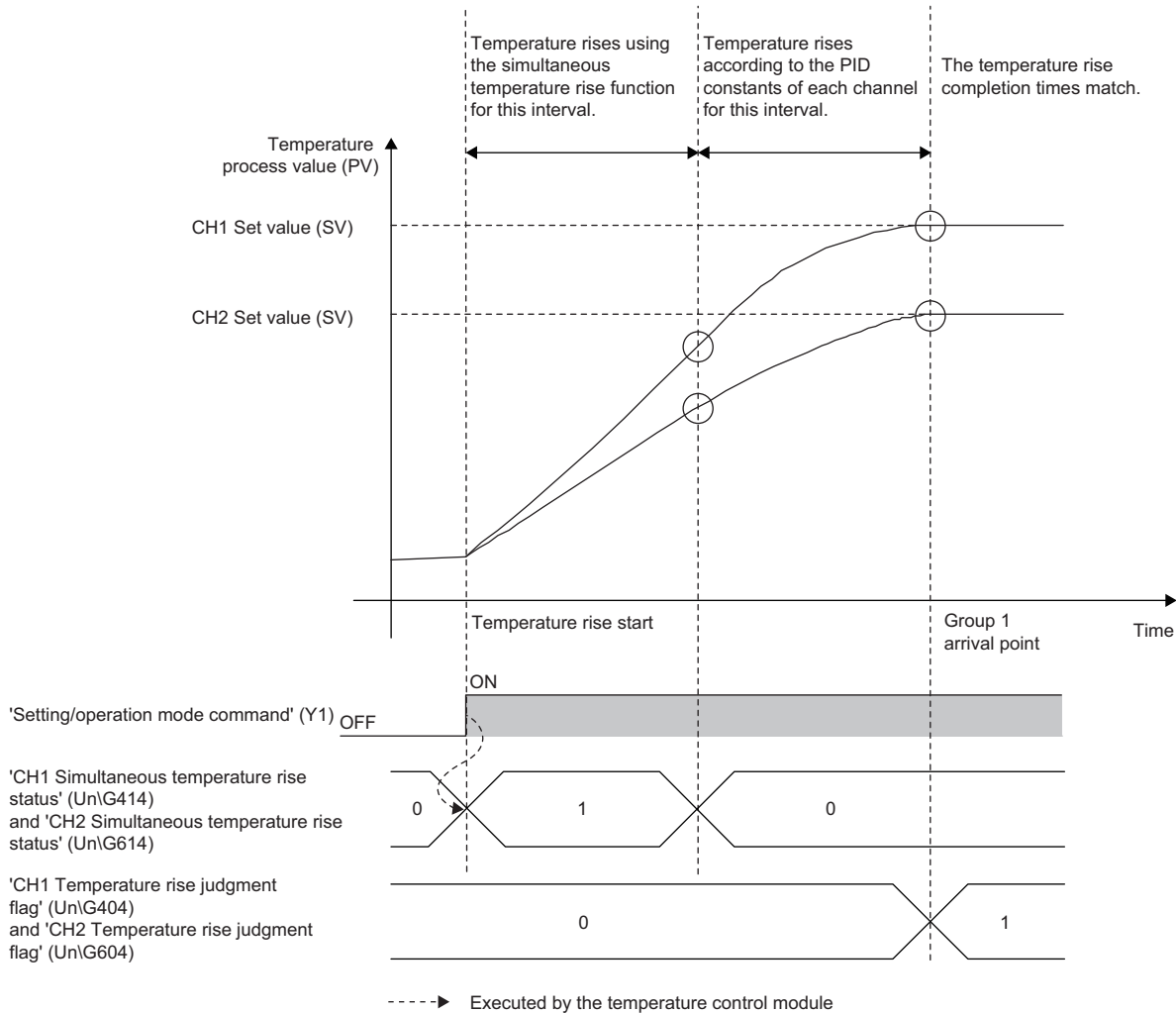

Completion of the temperature rise does not set 'CH1 Simultaneous temperature rise status' (UnG414) to Simultaneous temperature rise not in process (0).

As shown in the figure above, the simultaneous temperature rise function raises the temperature to a certain point, and Simultaneous temperature rise in process (1) is set during the temperature rise. After the point, the temperature rises based on the PID constants of CH1, and Simultaneous temperature rise not in process (0) is set.

For details on the simultaneous temperature rise function, refer to the following.

☞ Page 97 Simultaneous Temperature Rise Function

■ Buffer memory address

The following shows the buffer memory address of this area.

Buffer memory area name	CH1	CH2	CH3	CH4
CH□ Simultaneous temperature rise status	414	614	814	1014
CH□ Simultaneous temperature rise status (in the Q compatible mode)	734	750	766	782

CH1 Feed forward control forced start status

The feed forward control forced start status can be checked in this area.

When the temperature control module starts the feed forward control after 'CH1 Feed forward control forced starting signal' (Un\G559) is set to Feed forward control forced start (1), Forced start in progress (1) will be stored in this area.

- 0: Forced start stop
- 1: Forced start in progress

■Buffer memory address

The following shows the buffer memory address of this area.

Buffer memory area name	CH1	CH2	CH3	CH4
CH□ Feed forward control forced start status	415	615	815	1015
CH□ Feed forward control forced start status (in the Q compatible mode)	1450	1451	1452	1453

CH1 Feed forward value tuning flag

The feed forward value tuning status can be checked in this area.

When 'CH1 Feed forward value tuning selection' (Un\G561) is set to No automatic setting (0), all bits of this flag turn off.

- 0: Off
- 1: On

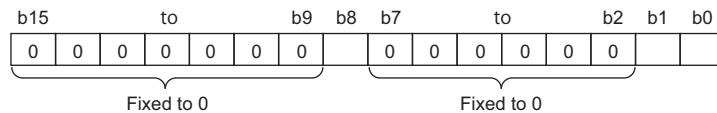

Bit	Flag name	Description
b0	Feed forward value change flag	This bit turns on when the feed forward value is automatically set.
b1	Feed forward value tuning execution status	This bit turns on when the feed forward value tuning starts.
b2 to b7	— (Fixed to 0)	— (Not used)
b8	Feed forward value tuning error flag	This bit turns on when the feed forward value after the tuning is abnormal.
b9 to b15	— (Fixed to 0)	— (Not used)

■Buffer memory address

The following shows the buffer memory address of this area.

Buffer memory area name	CH1	CH2	CH3	CH4
CH□ Feed forward value tuning flag	416	616	816	1016
CH□ Feed forward value tuning flag (in the Q compatible mode)	1454	1455	1456	1457

CH1 Feed forward control READY flag

When one of the following conditions is met while the action conditions of the disturbance suppression function have been met, this flag turns on.

Condition

The deviation (E) enters the disturbance judgment position and the process value (PV) is judged to be stable enough (It may take about 60 seconds to judge the stability.).

When the deviation enters within a half range of the disturbance judgment position under the following conditions

- The deviation enters the disturbance judgment position due to the rise of the temperature process value (PV).
- The deviation enters the disturbance judgment position due to the fall of the temperature process value (PV).

Point

This flag is disabled when the deviation (E) enters within the half range of the disturbance judgment position due to the following causes.

- Changing the set value (SV)
- Changing the setting mode to the operation mode
- At the completion of auto tuning

For details on the disturbance suppression function, refer to the following.

☞ Page 113 Disturbance Suppression Function

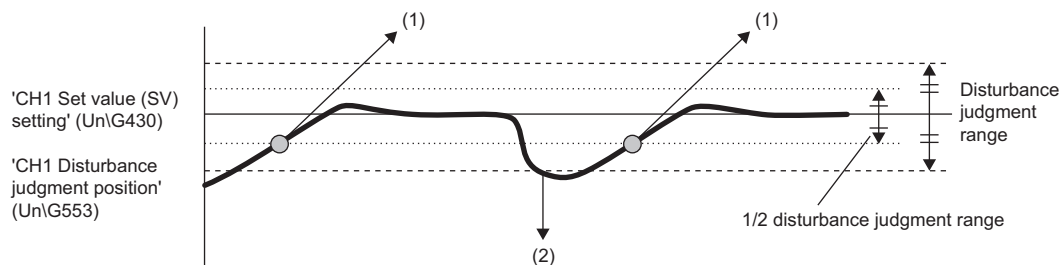

(1) Because the deviation (E) is within the 1/2 disturbance judgment width, 'CH1 Feed forward control READY flag' (UnG417) turns on.

(2) The disturbance suppression function starts.

■Buffer memory address

The following shows the buffer memory address of this area.

Buffer memory area name	CH1	CH2	CH3	CH4
CH□ Feed forward control READY flag	417	617	817	1017
CH□ Feed forward control READY flag (in the Q compatible mode)	1458	1459	1460	1461

■Turning off 'CH1 Feed forward control READY flag' (UnG417)

At the following timing, 'CH1 Feed forward control READY flag' (UnG417) turns off.

- At power-on
- During the disturbance suppression
- When the action conditions of the disturbance suppression function have not been satisfied
- When the temperature process value (PV) has responded in a reverse direction of the disturbance judgment position and goes outside the disturbance judgment width
- When the setting of 'CH1 Feed forward value tuning selection' (UnG561) is changed from No automatic setting (0) to Automatic setting (1) (The tuning is executed on the disturbance after the change.)

■Precautions

This function uses a noise filter to avoid a false detection for the disturbance judgment.

Thus, if the temperature fluctuation caused by disturbance is steep in terms of time, the disturbance judgment may delay.

CH1 Feed forward control forced start READY flag

When the deviation (E) enters the disturbance judgment position and the temperature process value (PV) is judged to be stable enough (It may take about 60 seconds to judge the stability.) while the action conditions of the disturbance suppression function have been satisfied, this flag turns on. For details on the disturbance suppression function, refer to the following.

☞ Page 113 Disturbance Suppression Function

- 0: Off
- 1: On

■Buffer memory address

The following shows the buffer memory address of this area.

Buffer memory area name	CH1	CH2	CH3	CH4
CH□ Feed forward control forced start READY flag	418	618	818	1018
CH□ Feed forward control forced start READY flag (in the Q compatible mode)	1462	1463	1464	1465

■Turning off 'CH1 Feed forward control forced start READY flag' (Un\G418)

At the following timing, 'CH1 Feed forward control forced start READY flag' (Un\G418) turns off.

- At power-on
- During the disturbance suppression
- When the action conditions of the disturbance suppression function have not been satisfied
- When the temperature process value (PV) has responded in a reverse direction of the disturbance judgment position and goes outside the disturbance judgment width
- When the setting of 'CH1 Feed forward value tuning selection' (Un\G561) is changed from No automatic setting (0) to Automatic setting (1) (The tuning is executed on the disturbance after the change.)

CH1 Sensor two-point correction offset latch completion

When the latch of the sensor two-point correction offset value is completed, Latch completed (1) is stored in this area.

When 'CH1 Sensor two-point correction offset latch request' (Un\G566) is set to No request (0), No request (0) is stored in this area.

For details on the sensor two-point correction function, refer to the following.

☞ Page 56 Sensor Correction Function

■Buffer memory address

The following shows the buffer memory address of this area.

Buffer memory area name	CH1	CH2	CH3	CH4
CH□ Sensor two-point correction offset latch completion	419	619	819	1019
CH□ Sensor two-point correction offset latch completion (in the Q compatible mode)	549	581	613	645

CH1 Sensor two-point correction gain latch completion

When the latch of the sensor two-point correction gain value is completed, Latch completed (1) is stored in this area.

When 'CH1 Sensor two-point correction gain latch request' (Un\G567) is set to No request (0), No request (0) is stored in this area.

For details on the sensor two-point correction function, refer to the following.

☞ Page 56 Sensor Correction Function

■Buffer memory address

The following shows the buffer memory address of this area.

Buffer memory area name	CH1	CH2	CH3	CH4
CH□ Sensor two-point correction gain latch completion	420	620	820	1020
CH□ Sensor two-point correction gain latch completion (in the Q compatible mode)	551	583	615	647

CH1 Set value (SV) setting

Set the target temperature value of the PID control.

■Buffer memory address

The following shows the buffer memory address of this area.

Buffer memory area name	CH1	CH2	CH3	CH4
CH□ Set value (SV) setting	430	630	830	1030
CH□ Set value (SV) setting (in the Q compatible mode)	34	66	98	130

■Setting range

The range is determined by the values set in 'CH1 Upper limit setting limiter' (Un\G511) and 'CH1 Lower limit setting limiter' (Un\G512). ( Page 259 CH1 Upper limit setting limiter, Page 260 CH1 Lower limit setting limiter)

When a value out of the setting range is set in this area, an out of setting range error (error code: 1950H) occurs and the following operations will be executed.

- 'Error flag' (X2) turns on.
- An error code is stored in 'Latest error code' (Un\G0).

■Setting unit

The value to be set differs depending on the value stored in 'CH1 Decimal point position' (Un\G400). ( Page 223 CH1 Decimal point position)

- No decimal point (0): Set a value in increments of 1°C (°F or digit).
- First decimal place (1): Set a value (the value multiplied by 10) in increments of 0.1°C (°F).

■Default value

The default value is 0.

CH1 Proportional band (P) setting

Set the proportional band (P) to execute the PID control.

The proportional band (P) is the deviation width of the deviation (E) necessary for the manipulated value (MV) to vary within the range of 0% to 100%.

In a proportional action, the relation between changes in the deviation (E) and the manipulated value (MV) can be expressed as follows:

$$MV = K_p \cdot E$$

K_p is a proportional gain. The following formula shows the proportional band (P).

$$P = \frac{1}{K_p} \cdot 100$$

When the value of the proportional band (P) increases, the proportional gain (K_p) decreases. Therefore, the variation of the manipulated value (MV) becomes small compared to the variation of the deviation (E).

When the value of the proportional band (P) decreases, the proportional gain (K_p) increases. Therefore, the variation of the manipulated value (MV) becomes large compared to the variation of the deviation (E). The following figure shows the proportional band (P) in a reverse action.

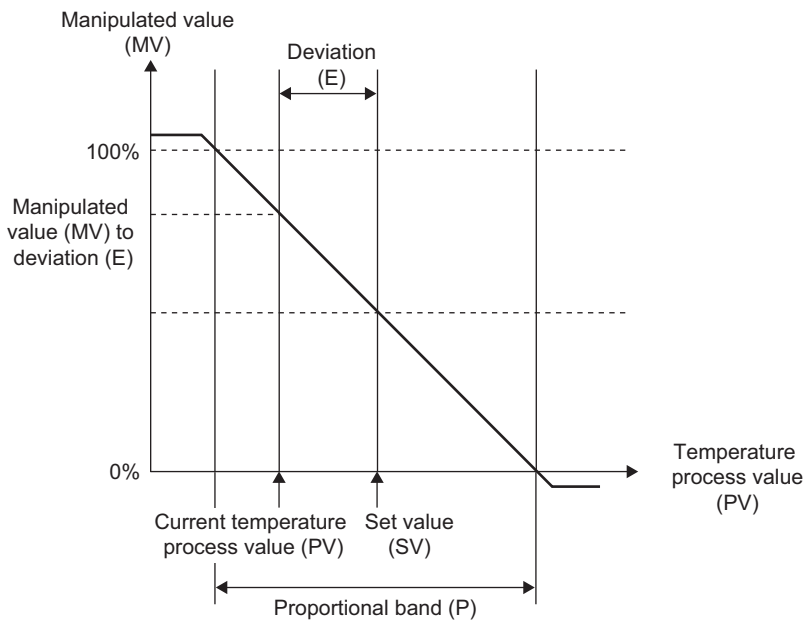

■ Buffer memory address

The following shows the buffer memory address of this area.

Buffer memory area name	CH1	CH2	CH3	CH4
CH□ Proportional band (P) setting	431	631	831	1031
CH□ Proportional band (P) setting (in the Q compatible mode)	35	67	99	131

■ Setting range

- In the R mode
0 to the full scale of the input range (°C(°F))
- In the Q compatible mode
0 to 10000 (0.0% to 1000.0%)

Ex.

In the Q compatible mode, when the following values have been set in the buffer memory areas, the proportional band (P) becomes 60°C.

- 'CH1 Input range' (in the Q compatible mode) (Un\G32): 38 (Temperature measuring range: -200.0°C to 400.0°C)
- 'CH1 Proportional band (P) setting' (in the Q compatible mode) (Un\G35): 100 (10.0%)

$$(\text{Full scale}) \times (\text{Proportional band (P) setting}) = (400.0^\circ\text{C} - (-200.0^\circ\text{C})) \times 0.1 = 60^\circ\text{C}$$

■ Two-position control

Set the proportional band (P) to 0.

For details on the two-position control, refer to the following.

☞ Page 16 Control Method

■ Default value

- In the R mode
For the R60TCTRT2TT2 and the R60TCTRT2TT2BW, the default value is 30 (30°C).
For the R60TCRT4 and the R60TCRT4BW, the default value is 30 (3.0°C).
- In the Q compatible mode
The default value is 30 (3.0%).

When the proportional band (P) has been set to 0, the auto tuning cannot be executed.
 To execute the auto tuning, set the proportional band (P) to a value other than 0.
 For details on the auto tuning function, refer to the following.
 Page 35 Auto Tuning Function

CH1 Heating proportional band (Ph) setting

Set the heating proportional band (Ph) to execute the PID control. For details on this area, refer to the following.
 Page 238 CH1 Proportional band (P) setting

■Buffer memory address

The following shows the buffer memory address of this area.

Buffer memory area name	CH1	CH2	CH3	CH4
CH□ Heating proportional band (Ph) setting	431	631	831	1031
CH□ Heating proportional band (Ph) setting (in the Q compatible mode)	35	67	99	131

■Setting range

- In the R mode
0 to the full scale of the input range (°C(°F))
- In the Q compatible mode
0 to 10000 (0.0% to 1000.0%)

■Two-position control

Set the heating proportional band (Ph) to 0.
 For details on the two-position control, refer to the following.
 Page 16 Control Method

■Default value

- In the R mode
For the R60TCTRT2TT2 and the R60TCTRT2TT2BW, the default value is 30 (30°C).
For the R60TCRT4 and the R60TCRT4BW, the default value is 30 (3.0°C).
- In the Q compatible mode
The default value is 30 (3.0%).

CH1 Integral time (I) setting

Set the integral time (I) to execute the PID control.

■Buffer memory address

The following shows the buffer memory address of this area.

Buffer memory area name	CH1	CH2	CH3	CH4
CH□ Integral time (I) setting	432	632	832	1032
CH□ Integral time (I) setting (in the Q compatible mode)	36	68	100	132

■Setting range

- Other than the position-proportional control
The setting range is 0 to 3600 (0 to 3600s).
- Position-proportional control
The setting range is 1 to 3600 (1 to 3600s).

■P control or PD control

Set 0. For details on control methods, refer to the following.
 Page 16 Control Method

■Default value

The default value is 240 (240s).

CH1 Derivative time (D) setting

Set the derivative time (D) to execute the PID control.

■Buffer memory address

The following shows the buffer memory address of this area.

Buffer memory area name	CH1	CH2	CH3	CH4
CH□ Derivative time (D) setting	433	633	833	1033
CH□ Derivative time (D) setting (in the Q compatible mode)	37	69	101	133

■Setting range

The setting range is 0 to 3600 (0 to 3600s).

■P control or PI control

Set 0. For details on control methods, refer to the following.

☞ Page 16 Control Method

■Default value

The default value is 60 (60s).

CH1 Alert set value 1

According to a selected alert mode of Alert 1, set the temperature at which CH1 Alert 1 (Un\G401, b8) turns on.

For 'CH1 Alert definition' (Un\G401), refer to the following.

☞ Page 224 CH1 Alert definition

For details on the alert function, refer to the following.

☞ Page 69 Alert Function

■Buffer memory address

The following shows the buffer memory address of this area.

Buffer memory area name	CH1	CH2	CH3	CH4
CH□ Alert set value 1	434	634	834	1034
CH□ Alert set value 1 (in the Q compatible mode)	38	70	102	134

■Alert mode

Set the alert mode of Alert 1 in the following buffer memory area. The alert mode of Alert 1 corresponds to 'CH1 Alert set value 1' (Un\G434).

- 'CH1 Alert 1 mode setting' (Un\G533)

■Setting range

The setting range differs depending on the setting of the following buffer memory area. (Each full scale differs.)

- 'CH1 Input range' (Un\G501) (☞ Page 247 CH1 Input range)

The setting range also depends on the alert mode to be set.

Alert mode	Setting range of Alert set value	Remarks
No alert	0	—
Upper limit input alert, lower limit input alert	Temperature measuring range of the input range	Same as with standby
Upper limit deviation alert, lower limit deviation alert, upper limit deviation alert (set value (SV) used), lower limit deviation alert (set value (SV) used)	-(Full scale) to Full scale	Same as with standby and standby (second time)
Upper/lower limit deviation alert, within-range alert, upper/lower limit deviation alert (set value (SV) used), within-range alert (set value (SV) used)	0 to Full scale	Same as with standby and standby (second time)

When a value out of the setting range is set in this area, an out of setting range error (error code: 1950H) occurs and the following operations will be executed.

- 'Error flag' (X2) turns on.
- An error code is stored in 'Latest error code' (Un\G0).

■Setting unit

The value to be set differs depending on the value stored in 'CH1 Decimal point position' (Un\G400). (☞ Page 223 CH1 Decimal point position)

- No decimal point (0): Set a value in increments of 1°C (°F or digit).
- First decimal place (1): Set a value (the value multiplied by 10) in increments of 0.1°C (°F).

■Default value

The default value is 0.

CH1 Alert set value 2

According to a selected alert mode of Alert 2, set the temperature at which CH1 Alert 2 (Un\G401, b9) turns on.

For 'CH1 Alert definition' (Un\G401), refer to the following.

☞ Page 224 CH1 Alert definition

For details on the alert function, refer to the following.

☞ Page 69 Alert Function

■Buffer memory address

The following shows the buffer memory address of this area.

Buffer memory area name	CH1	CH2	CH3	CH4
CH□ Alert set value 2	435	635	835	1035
CH□ Alert set value 2 (in the Q compatible mode)	39	71	103	135

■Alert mode

Set the alert mode of Alert 2 in the following buffer memory area. The alert mode of Alert 2 corresponds to 'CH1 Alert set value 2' (Un\G435).

- 'CH1 Alert 2 mode setting' (Un\G534)

■Setting range

For the setting range, refer to the following.

☞ Page 241 Setting range

■Setting unit

For the setting unit, refer to the following.

☞ Page 242 Setting unit

■Default value

The default value is 0.

CH1 Alert set value 3

According to a selected alert mode of Alert 3, set the temperature at which CH1 Alert 3 (Un\G401, b10) turns on.

For 'CH1 Alert definition' (Un\G401), refer to the following.

☞ Page 224 CH1 Alert definition

For details on the alert function, refer to the following.

☞ Page 69 Alert Function

■Buffer memory address

The following shows the buffer memory address of this area.

Buffer memory area name	CH1	CH2	CH3	CH4
CH□ Alert set value 3	436	636	836	1036
CH□ Alert set value 3 (in the Q compatible mode)	40	72	104	136

■Alert mode

Set the alert mode of Alert 3 in the following buffer memory area. The alert mode of Alert 3 corresponds to 'CH1 Alert set value 3' (Un\G436).

- 'CH1 Alert 3 mode setting' (Un\G535)

■Setting range

For the setting range, refer to the following.

☞ Page 241 Setting range

■Setting unit

For the setting unit, refer to the following.

☞ Page 242 Setting unit

■Default value

The default value is 0.

CH1 Alert set value 4

According to a selected alert mode of Alert 4, set the temperature at which CH1 Alert 4 (Un\G401, b11) turns on.

For 'CH1 Alert definition' (Un\G401), refer to the following.

☞ Page 224 CH1 Alert definition

For details on the alert function, refer to the following.

☞ Page 69 Alert Function

■Buffer memory address

The following shows the buffer memory address of this area.

Buffer memory area name	CH1	CH2	CH3	CH4
CH□ Alert set value 4	437	637	837	1037
CH□ Alert set value 4 (in the Q compatible mode)	41	73	105	137

■Alert mode

Set the alert mode of Alert 4 in the following buffer memory area. The alert mode of Alert 4 corresponds to 'CH1 Alert set value 4' (Un\G437).

- 'CH1 Alert 4 mode setting' (Un\G536)

■Setting range

For the setting range, refer to the following.

☞ Page 241 Setting range

■Setting unit

For the setting unit, refer to the following.

☞ Page 242 Setting unit

■Default value

The default value is 0.

CH1 Temperature process value (PV) for input with another analog module

The digital input value of the current or voltage converted in another analog module (such as A/D converter module) on the system can be used as a temperature process value (PV). Store the digital input value of the current or voltage converted by another analog module (such as A/D converter module) in this area. For details, refer to the following.

☞ Page 68 Input

Point

When a value out of the set input range is stored, the value to be used for control is fixed to the upper limit value or the lower limit value of the input range.

■Buffer memory address

The following shows the buffer memory address of this area.

Buffer memory area name	CH1	CH2	CH3	CH4
CH□ Temperature process value (PV) for input with another analog module	438	638	838	1038
CH□ Temperature process value (PV) for input with another analog module (in the Q compatible mode)	689	690	691	692

■Default value

The default value is 0.

CH1 Cooling proportional band (Pc) setting

Set the cooling proportional band (Pc) to execute the PID control. For details on this area, refer to the following.

☞ Page 238 CH1 Proportional band (P) setting

■Buffer memory address

The following shows the buffer memory address of this area.

Buffer memory area name	CH1	CH2	CH3	CH4
CH□ Cooling proportional band (Pc) setting	439	639	839	1039
CH□ Cooling proportional band (Pc) setting (in the Q compatible mode)	720	736	752	768

■Setting range

- In the R mode
1 to the full scale of the input range (°C(°F))
- In the Q compatible mode
1 to 10000 (0.1% to 1000.0%)

■Default value

- In the R mode
For the R60TCTRT2TT2 and the R60TCTRT2TT2BW, the default value is 30 (30°C).
For the R60TCRT4 and the R60TCRT4BW, the default value is 30 (3.0°C).
- In the Q compatible mode
The default value is 30 (3.0%).

CH1 Memory's PID constants read command

PID constants are read from the non-volatile memory and stored in the buffer memory by using this command. Setting this buffer memory area to Requested (1) stores the value backed up in the non-volatile memory to the buffer memory.

■Buffer memory address

The following shows the buffer memory address of this area.

Buffer memory area name	CH1	CH2	CH3	CH4
CH□ Memory's PID constants read command	440	640	840	1040
CH□ Memory's PID constants read command (in the Q compatible mode)	62	94	126	158

■Buffer memory areas to store set values in the non-volatile memory

The following table lists the buffer memory areas from which set values are read.



Buffer memory area name	Buffer memory address	Reference
CH1 Proportional band (P) setting	Un\G431	Page 238 CH1 Proportional band (P) setting
CH1 Heating proportional band (Ph) setting	Un\G431	Page 240 CH1 Heating proportional band (Ph) setting
CH1 Cooling proportional band (Pc) setting	Un\G439	Page 244 CH1 Cooling proportional band (Pc) setting
CH1 Integral time (I) setting	Un\G432	Page 240 CH1 Integral time (I) setting
CH1 Derivative time (D) setting	Un\G433	Page 241 CH1 Derivative time (D) setting
CH1 Loop disconnection detection judgment time	Un\G537	Page 275 CH1 Loop disconnection detection judgment time

■Setting range

- 0: Not requested
- 1: Requested

■Precautions

When this command has been set to Requested (1), do not execute the following operations. An incorrect value may be stored in the non-volatile memory.

- Changing set values in the buffer memory read from the non-volatile memory by using this command
- Memory backup ( Page 119 Buffer Memory Data Backup Function)
- Default setting registration ( Page 159 Default setting registration command)
- Auto tuning ( Page 35 Auto Tuning Function)

Point

- When the initial setting of the engineering tool has already been configured in the Q compatible mode, backing up PID constants to the non-volatile memory after the auto tuning is recommended. Turning on this command at the next start-up can omit the auto tuning.
- This command is enabled in both the setting mode and operation mode. However, this command is disabled while 'CH1 Auto tuning command' (Y4) is on.

A

■Default value

The default value is Not requested (0).

CH1 Feed forward value memory read command

A feed forward value is read from the non-volatile memory and stored in the buffer memory by using this command. Setting this buffer memory area to Requested (1) stores the value backed up in the non-volatile memory to the buffer memory.

■Buffer memory address

The following shows the buffer memory address of this area.

Buffer memory area name	CH1	CH2	CH3	CH4
CH□ Feed forward value memory read command	441	641	841	1041
CH□ Feed forward value memory read command (in the Q compatible mode)	1200	1216	1232	1248

■Buffer memory areas to store set values in the non-volatile memory

The following table lists the buffer memory areas from which set values are read.



Buffer memory area name	Buffer memory address	Reference
CH1 Feed forward value	Un\G560	Page 291 CH1 Feed forward value

■Setting range

- 0: Not requested
- 1: Requested

■Precautions

When this command has been set to Requested (1), do not execute the following operations. An incorrect value may be stored in the non-volatile memory.

- Changing set values in the buffer memory read from the non-volatile memory by using this command
- Memory backup ( Page 119 Buffer Memory Data Backup Function)
- Default setting registration ( Page 159 Default setting registration command)

Point

This command is enabled in both the setting mode and operation mode. However, this command is disabled while CH1 Feed forward value tuning execution status (Un\G416, b1) is on.

■Default value

The default value is Not requested (0).

CH1 HOLD/CLEAR setting

Set whether to hold or clear the transistor output status when a stop error occurs in the CPU module or when the CPU module is turned from RUN to STOP. For the status of the temperature control module of when this setting is configured, refer to the following.

 Page 24 HOLD/CLEAR Function

- 0: CLEAR
- Other than 0: HOLD

■Buffer memory address

The following shows the buffer memory address of this area.

Buffer memory area name	CH1	CH2	CH3	CH4
CH□ HOLD/CLEAR setting	500	700	900	1100

■Default value

The default value is CLEAR (0).

HOLD/CLEAR setting (Q compatible mode)

In the Q compatible mode, set whether to hold or clear the transistor output status when a stop error occurs in the CPU module or when the CPU module is turned from RUN to STOP. For the status of the temperature control module of when this setting is configured, refer to the following.

 Page 24 HOLD/CLEAR Function

b15 to b12	b11 to b8	b7 to b4	b3 to b0
CH4	CH3	CH2	CH1

- 0: CLEAR
- Other than 0: HOLD

■Buffer memory address

The following shows the buffer memory address of this area.

Buffer memory area name	CH1	CH2	CH3	CH4
CH□ HOLD/CLEAR setting (in the Q compatible mode)	1026			

■Default value

The default value is CLEAR (0) in CH1 to CH4.

CH1 Input range

Select corresponding setting values from the temperature sensors used with the temperature control module, temperature measuring range, temperature unit to be output (Celsius (°C)/Fahrenheit (°F)/digit) and resolution (1/0.1).



For inputs from other analog modules (such as an A/D converter module) also, set these values.

Ex.

When selecting the following thermocouple

- Thermocouple type: R
- Temperature measuring range: 0°C to 1700°C
- Resolution: 1

Set 'CH1 Input range' (Un\G501) to 1.

■ Buffer memory address

The following shows the buffer memory address of this area.

Buffer memory area name	CH1	CH2	CH3	CH4
CH□ Input range	501	701	901	1101
CH□ Input range (in the Q compatible mode)	32	64	96	128

■ Setting value and type of thermocouple

The following table lists the setting values of 'CH1 Input range' (Un\G501) and the corresponding thermocouple types. The relation between each temperature unit and setting value is also shown as follows.

- Temperature unit

Setting of 'CH1 Input range' (Un\G501)	Item	
1 to 99	A thermocouple is used.	When the output temperature unit is Celsius (°C)
100 to 199		When the output temperature unit is Fahrenheit (°F)
200 to 299	Other analog modules (such as an A/D converter module) are used.	When the unit is digit

- Setting value

Thermocouple type	Temperature measuring range	Celsius (°C), Fahrenheit (°F), digit	Resolution	'CH1 Input range' (Un\G501)	Automatic setting at input range change*1	
					'CH1 Upper limit setting limiter' (Un\G511)	'CH1 Lower limit setting limiter' (Un\G512)
R	0 to 1700	°C	1	1	1700	0
	0 to 3000	°F	1	105	3000	0
K	0 to 1300	°C	1	2 (default value)	1300	0
	0 to 500	°C	1	11	500	0
	0 to 800	°C	1	12	800	0
	0.0 to 400.0	°C	0.1	36	4000	0
	-200.0 to 400.0	°C	0.1	38	4000	-2000
	0.0 to 500.0	°C	0.1	40	5000	0
	0.0 to 800.0	°C	0.1	41	8000	0
	-200.0 to 1300.0	°C	0.1	49	13000	-2000
	0 to 1000	°F	1	100	1000	0
	0 to 2400	°F	1	101	2400	0
0.0 to 1000.0	°F	0.1	130	10000	0	

A

Thermocouple type	Temperature measuring range	Celsius (°C), Fahrenheit (°F), digit	Resolution	'CH1 Input range' (Un\G501)	Automatic setting at input range change*1	
					'CH1 Upper limit setting limiter' (Un\G511)	'CH1 Lower limit setting limiter' (Un\G512)
J	0 to 1200	°C	1	3	1200	0
	0 to 500	°C	1	13	500	0
	0 to 800	°C	1	14	800	0
	0.0 to 400.0	°C	0.1	37	4000	0
	0.0 to 500.0	°C	0.1	42	5000	0
	0.0 to 800.0	°C	0.1	43	8000	0
	-200.0 to 1000.0	°C	0.1	50	10000	-2000
	0 to 1000	°F	1	102	1000	0
	0 to 1600	°F	1	103	1600	0
	0 to 2100	°F	1	104	2100	0
0.0 to 1000.0	°F	0.1	131	10000	0	
T	-200 to 400	°C	1	4	400	-200
	0 to 200	°C	1	19	200	0
	0 to 400	°C	1	20	400	0
	-200 to 200	°C	1	21	200	-200
	-200.0 to 400.0	°C	0.1	39	4000	-2000
	0.0 to 400.0	°C	0.1	45	4000	0
	-300 to 400	°F	1	110	400	-300
	0 to 700	°F	1	109	700	0
	0.0 to 700.0	°F	0.1	132	7000	0
S	0 to 1700	°C	1	15	1700	0
	0 to 3000	°F	1	106	3000	0
B	0 to 1800	°C	1	16	1800	0
	0 to 3000	°F	1	107	3000	0
E	0 to 400	°C	1	17	400	0
	0 to 1000	°C	1	18	1000	0
	0.0 to 700.0	°C	0.1	44	7000	0
	-200.0 to 1000.0	°C	0.1	51	10000	-2000
	0 to 1800	°F	1	108	1800	0
N	0 to 1300	°C	1	22	1300	0
	0.0 to 1000.0	°C	0.1	52	10000	0
	0 to 2300	°F	1	111	2300	0
U	-200 to 200	°C	1	26	200	-200
	0 to 400	°C	1	25	400	0
	0.0 to 600.0	°C	0.1	46	6000	0
	-300 to 400	°F	1	115	400	-300
	0 to 700	°F	1	114	700	0
L	0 to 400	°C	1	27	400	0
	0.0 to 400.0	°C	0.1	47	4000	0
	0 to 900	°C	1	28	900	0
	0.0 to 900.0	°C	0.1	48	9000	0
	0 to 800	°F	1	116	800	0
	0 to 1600	°F	1	117	1600	0
PLII	0 to 1200	°C	1	23	1200	0
	0 to 2300	°F	1	112	2300	0
WRe5-26	0 to 2300	°C	1	24	2300	0
	0 to 3000	°F	1	113	3000	0
Input with another analog module (0 to 4000)	0 to 4000	digit	1	201	4000	0

Thermocouple type	Temperature measuring range	Celsius (°C), Fahrenheit (°F), digit	Resolution	'CH1 Input range' (Un\G501)	Automatic setting at input range change*1	
					'CH1 Upper limit setting limiter' (Un\G511)	'CH1 Lower limit setting limiter' (Un\G512)
Input with another analog module (0 to 12000)	0 to 12000	digit	1	202	12000	0
Input with another analog module (0 to 16000)	0 to 16000	digit	1	203	16000	0
Input with another analog module (0 to 20000)	0 to 20000	digit	1	204	20000	0
Input with another analog module (0 to 32000)	0 to 32000	digit	1	205	32000	0

*1 When the input range is changed, the set values in some buffer memory areas are initialized automatically and return to the default values.

Restriction

For the following modes and channels, 'CH1 Input range' (Un\G501) cannot be set to a value of 201 to 205. When the value is set, an out of setting range error (error code: 1950H) occurs.

- Heating-cooling control (normal mode), position-proportional control (normal mode): CH3, CH4
- Mix control (normal mode): CH2

Setting value and platinum resistance thermometer type

The following table lists the setting values of 'CH1 Input range' (Un\G501) and the corresponding platinum resistance thermometer types.

Platinum resistance thermometer	Temperature measuring range	Celsius (°C), Fahrenheit (°F), digit	Resolution	'CH1 Input range' (Un\G501)	Automatic setting at input range change*1	
					'CH1 Upper limit setting limiter' (Un\G511)	'CH1 Lower limit setting limiter' (Un\G512)
Pt100	-200.0 to 600.0	°C	0.1	7 (default value)	6000	-2000
	-200.0 to 200.0	°C	0.1	8	2000	-2000
	-200.0 to 850.0	°C	0.1	54	8500	-2000
	-300 to 1100	°F	1	141	1100	-300
	-300.0 to 300.0	°F	0.1	143	3000	-3000
JPt100	-200.0 to 500.0	°C	0.1	5	5000	-2000
	-200.0 to 200.0	°C	0.1	6	2000	-2000
	-200.0 to 640.0	°C	0.1	53	6400	-2000
	-300 to 900	°F	1	140	900	-300
	-300.0 to 300.0	°F	0.1	142	3000	-3000
Another analog input module (0 to 4000)	0 to 4000	digit	1	201	4000	0
Another analog input module (0 to 12000)	0 to 12000	digit	1	202	12000	0
Another analog input module (0 to 16000)	0 to 16000	digit	1	203	16000	0
Another analog input module (0 to 20000)	0 to 20000	digit	1	204	20000	0
Another analog input module (0 to 32000)	0 to 32000	digit	1	205	32000	0

*1 When the input range is changed, the set values in some buffer memory areas are initialized automatically and return to the default values.

Resolution

The resolution is applied to the values stored and the values set in particular buffer memory areas as described in the following table.

Resolution	Stored value	Setting value
1	A value in increments of 1°C (°F or digit) is stored.	Set a value in increments of 1°C (°F or digit).
0.1	A value in increments of 0.1°C (°F or digit) (the value multiplied by 10) is stored.	Set a value in increments of 0.1°C (°F or digit) (the value multiplied by 10).

For the buffer memory areas to which this setting is applied, refer to the following.

☞ Page 223 CH1 Decimal point position

When the input range automatic change setting has been set to Enable (1) ('Automatic setting at input range change' (in the Q compatible mode) (Un\G1024, b0) in the Q compatible mode)

When the input range is changed, the following buffer memory areas are set automatically depending on a selected temperature sensor. Set the buffer memory areas again if necessary.

- 'CH1 Upper limit setting limiter' (Un\G511)
- 'CH1 Lower limit setting limiter' (Un\G512)
- 'CH1 Set value (SV) setting' (Un\G430)
- 'CH1 Proportional band (P) setting' (Un\G431) (only R mode)
- 'CH1 Heating proportional band (Ph) setting' (Un\G431) (only R mode)
- 'CH1 Alert set value 1' (Un\G434)
- 'CH1 Alert set value 2' (Un\G435)
- 'CH1 Alert set value 3' (Un\G436)
- 'CH1 Alert set value 4' (Un\G437)
- 'CH1 Cooling proportional band (Pc) setting' (Un\G439) (only R mode)
- 'CH1 Setting variation rate limiter/setting variation rate limiter (temperature rise)' (Un\G513) (only R mode)
- 'CH1 Setting variation rate limiter (temperature drop)' (Un\G514) (only R mode)
- 'CH1 Adjustment sensitivity (dead band) setting' (Un\G516) (only R mode)
- 'CH1 Overlap/dead band setting' (Un\G524) (only R mode)
- 'CH1 Alert dead band setting' (Un\G531) (only R mode)
- 'CH1 Loop disconnection detection dead band' (Un\G538)
- 'CH1 AT bias' (Un\G546)
- 'CH1 Simultaneous temperature rise gradient data' (Un\G554)
- 'CH1 Simultaneous temperature rise dead time' (Un\G555)
- 'CH1 Disturbance judgment position' (Un\G557)
- 'CH1 Sensor correction value setting' (Un\G565) (only R mode)
- 'CH1 Sensor two-point correction offset value (measured value)' (Un\G568)
- 'CH1 Sensor two-point correction offset value (corrected value)' (Un\G569)
- 'CH1 Sensor two-point correction gain value (measured value)' (Un\G570)
- 'CH1 Sensor two-point correction gain value (corrected value)' (Un\G571)

■When the input range automatic change setting has been set to Disable (0) ('Automatic setting at input range change' (in the Q compatible mode) (Un\G1024, b0) in the Q compatible mode)

A value set in a buffer memory area may be out of the setting range. (Because changing the input range changes the setting range and the set value before the change may become out of the setting range after the change.) In this case, an out of setting range error (error code: 1950H) occurs in the buffer memory area where the set value is out of the setting range. Change the input range after setting a value within the setting range after the input range change in each buffer memory area.

■Enabling the settings

Turn on and off 'Setting change command' (YB) in the setting mode ('Setting/operation mode status' (X1): Off) to enable the settings.

■Precautions

Soon after the input range is changed, the input temperature may be unstable. Do not start the control until 'Temperature conversion completion flag' (Un\G43) becomes First temperature conversion completed (1H).

■Default value

- For the R60TCTRT2TT2 and the R60TCTRT2TT2BW, the default value is 2.
- For the R60TCRT4 and the R60TCRT4BW, the default value is 7.

CH1 Unused channel setting

Set this buffer memory area when handling channels to which no temperature control is executed or no temperature sensors are connected as "Unused". Setting those channels as unused channels stops alert detections on them.

For details on the unused channel setting, refer to the following.

 MELSEC iQ-R Temperature Control Module User's Manual (Startup)

■Buffer memory address

The following shows the buffer memory address of this area.

Buffer memory area name	CH1	CH2	CH3	CH4
CH□ Unused channel setting	502	702	902	1002
CH□ Unused channel setting (in the Q compatible mode)	61	93	125	157

■Setting range

- 0: Used
- 1: Not used

■Default value

The default value is Used (0).

■Turning on 'Default setting registration command' (Y9)

Turning off and on 'Default setting registration command' (Y9) resets the setting of 'CH1 Unused channel setting' (Un\G502) to Used (0).

When there are the channels to which no temperature control is executed or no temperature sensors are connected, set those channels as unused channels again after the completion of the default setting registration. Set 'CH1 Unused channel setting' (Un\G502) to Unused (1) again.

CH1 Stop mode setting

Set the mode to be activated when the PID control stops.

■Buffer memory address

The following shows the buffer memory address of this area.

Buffer memory area name	CH1	CH2	CH3	CH4
CH□ Stop mode setting	503	703	903	1103
CH□ Stop mode setting (in the Q compatible mode)	33	65	97	129

■Setting range and operation of the temperature control module

The following table lists the relation between them.

○: Executed, ×: Not executed

Setting mode	Setting value	Operation		
		PID control	Temperature judgment ^{*1}	Alert judgment ^{*2}
Stop	0	×	×	×
Monitor	1	×	○	×
Alert	2	×	○	○

*1 The temperature control module checks whether the input temperature is within the temperature measuring range of the input range.

*2 The temperature control module judges the occurrence of Alert 1 to Alert 4 and rate alarms.

However, an operation of the temperature control module differs depending on the following settings.

- 'CH1 Unused channel setting' (Un\G502) (☞ Page 251 CH1 Unused channel setting)
- 'Setting/operation mode command' (Y1) (☞ Page 158 Setting/operation mode command)
- 'PID continuation flag' (Un\G306) (☞ Page 220 PID continuation flag)
- 'CH1 PID control forced stop command' (YC) (☞ Page 160 PID control forced stop command)
- 'CH1 HOLD/CLEAR setting' (Un\G500) (☞ Page 246 CH1 HOLD/CLEAR setting)

For details, refer to the following.

- PID control (☞ Page 20 Condition to execute the PID control)
- Temperature judgment (☞ Page 224 CH1 Alert definition)
- Alert judgment (☞ Page 76 Condition for alert judgment)

■Default value

The default value is Monitor (1).

Point

The default value is Monitor (1).

Thus, sensor input disconnections are detected in channels to which no temperature sensors have been connected, and the ALM LED flashes.

When 'CH1 Unused channel setting' (Un\G502) has been set to Unused (1), control in CH1 is not executed.

For the channels to which no temperature sensors have been connected, set 'CH1 Unused channel setting' (Un\G502) to Unused (1).

CH1 Control output cycle setting

Set the pulse cycle (ON/OFF cycle) of the transistor output.

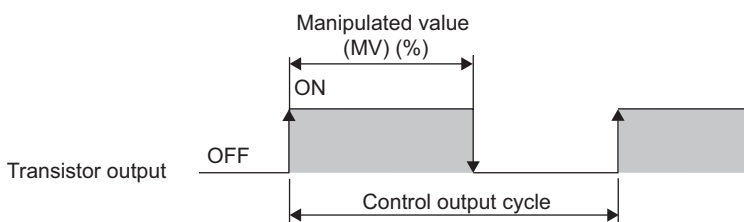

The ON time of the control output cycle is determined by multiplying the control output cycle by the manipulated value (MV) (%) calculated by a PID operation. When the manipulated value (MV) is stable, pulses are repeatedly output in the same cycle.

Ex.

When 700 (70%) has been stored in 'CH1 Manipulated value (MV)' (Un\G403) and the value in the following buffer memory area has been set as follows

- 'CH1 Control output cycle setting' (Un\G504): 100 (100s)

$$100\text{s} \times 0.7 (70\%) = 70\text{s}$$

The ON time is 70s. The transistor output is on for 70s and off for 30s per 100s.

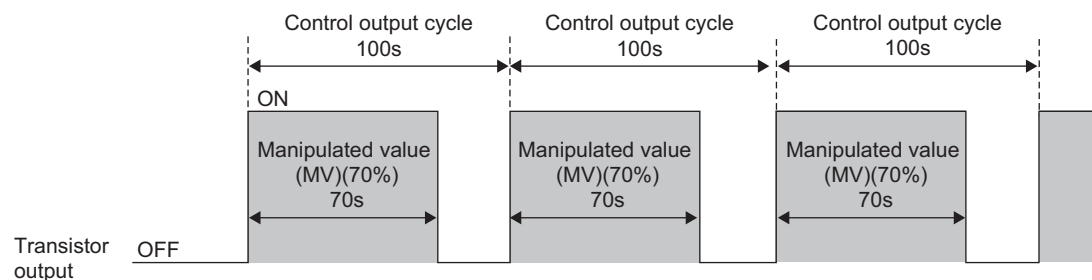

■ Buffer memory address

The following shows the buffer memory address of this area.

Buffer memory area name	CH1	CH2	CH3	CH4
CH□ Control output cycle setting	504	704	904	1104
CH□ Control output cycle setting (in the Q compatible mode)	47	79	111	143

■ Setting range

- In the R mode

'Control output cycle unit selection setting' (Un\G304)	Setting range
0: 1s cycle	1 to 100 (1 to 100s)
1: 0.1s cycle	5 to 1000 (0.5 to 100.0s)

- In the Q compatible mode

Control output cycle unit selection setting (in the Q compatible mode) (Un\G1024, b2)	Setting range
0: 1s cycle	1 to 100 (1 to 100s)
1: 0.1s cycle	5 to 1000 (0.5 to 100.0s)

■ Two-position control

The setting is ignored.

■ Default value

- 1s cycle: 30 (30s)
- 0.1s cycle: 300 (30s)

CH1 Heating control output cycle setting

Set the pulse cycle (ON/OFF cycle) of the transistor output.

The ON time of the control output cycle is determined by multiplying the control output cycle by the manipulated value for heating (MVh) (%) calculated by a PID operation. When the manipulated value for heating (MVh) is stable, pulses are repeatedly output in the same cycle. For details on this area, refer to the following.

☞ Page 253 CH1 Control output cycle setting

■Buffer memory address

The following shows the buffer memory address of this area.

Buffer memory area name	CH1	CH2	CH3	CH4
CH□ Heating control output cycle setting	504	704	904	1104
CH□ Heating control output cycle setting (in the Q compatible mode)	47	79	111	143

CH1 Control response parameter

In the simple two-degree-of-freedom PID control, select the response speed to the change of the set value (SV) from the following three levels: Slow, Normal, and Fast.

For details on the simple two-degree-of-freedom, refer to the following.

☞ Page 53 Simple Two-degree-of-freedom

■Buffer memory address

The following shows the buffer memory address of this area.

Buffer memory area name	CH1	CH2	CH3	CH4
CH□ Control response parameter	505	705	905	1105
CH□ Control response parameter (in the Q compatible mode)	49	81	113	145

■Setting range

Setting value	Setting details	Description
0	Slow	Set this value when reducing the overshoot and undershoot to the change of the set value (SV). However, the settling time becomes the longest among the three settings.
1	Normal	This setting has features between Slow and Fast.
2	Fast	Set this value when hastening the response to the change of the set value (SV). However, the overshoot and undershoot become the largest among the three settings.

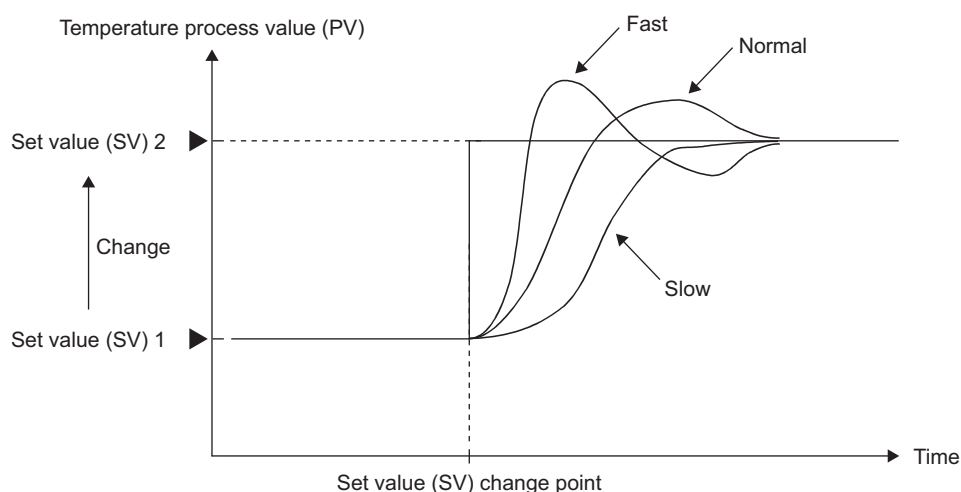

Point

Using the overshoot suppression function and setting the control response parameter to Fast (2) raise temperatures at a high speed while suppressing the overshoot. For the overshoot suppression function, refer to the following.

☞ Page 121 Overshoot Suppression Function

■Default value

The default value is Slow (0).

CH1 Temperature rise completion range setting

Set the width of the temperature rise completion range. When the temperature process value (PV) satisfies the following conditions, the temperature rise is completed.

- Set value (SV) - Temperature rise completion range ≤ Temperature process value (PV) ≤ Set value (SV) + Temperature rise completion range

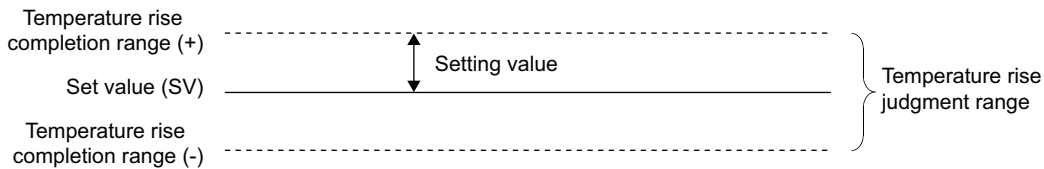

When the value set in 'CH1 Temperature process value (PV)' (Un\G402) goes within the temperature rise judgment range, 'CH1 Temperature rise judgment flag' (Un\G404) is set to Within temperature rise completion range (1). (For the time taken for 'CH1 Temperature rise judgment flag' (Un\G404) to set to Within temperature rise completion range (1) after the temperature rise completion, set the time in 'CH1 Temperature rise completion soak time setting' (Un\G507).)

■Buffer memory address

The following shows the buffer memory address of this area.

Buffer memory area name	CH1	CH2	CH3	CH4
CH□ Temperature rise completion range setting	506	706	906	1106
Temperature rise completion range setting (in the Q compatible mode)	167			

■Setting range

- In the R mode

Condition	Setting range
When the temperature unit of the input range is °C	1 (°C) to 100 (°C)
When the temperature unit of the input range is °F	1 (°F) to 100 (°F)
When the input range is for another analog module input	1 to 100

- In the Q compatible mode

Condition	Setting range
When the temperature unit of the input range is °C	1 (°C) to 10 (°C)
When the temperature unit of the input range is °F	1 (°F) to 10 (°F)
Other than above	1 to 10 (% of full scale)

■Default value

The default value is 1.

CH1 Temperature rise completion soak time setting

Set the time taken to set 'CH1 Temperature rise judgment flag' (Un\G404) to Within temperature rise completion range (1) after the completion of the temperature rise.

■Buffer memory address

The following shows the buffer memory address of this area.

Buffer memory area name	CH1	CH2	CH3	CH4
CH□ Temperature rise completion soak time setting	507	707	907	1107
Temperature rise completion soak time setting (in the Q compatible mode)	168			

■Setting range

The setting range is 0 to 3600 (min).

■Default value

The default value is 0 (min).

CH1 Upper limit output limiter

Set the upper limit value for actually outputting the manipulated value (MV) calculated by the PID operation to an external device.

■Buffer memory address

The following shows the buffer memory address of this area.

Buffer memory area name	CH1	CH2	CH3	CH4
CH□ Upper limit output limiter	508	708	908	1108
CH□ Upper limit output limiter (in the Q compatible mode)	42	74	106	138

■Setting range

The setting range is -50 to 1050 (-5.0 to 105.0%).

Set values so that the lower limit output limiter value is smaller than the upper limit output limiter value.

When the lower limit output limiter value is equal to or greater than the upper limit output limiter value, CH□ Upper/lower limit output limiter setting error (error code: 1A0□H) occurs.

When a value out of the setting value is set, an out of setting range error (error code: 1950H) occurs. When an error has occurred, the following operations will be executed.

- 'Error flag' (X2) turns on.
- An error code is stored in 'Latest error code' (Un\G0).



'CH1 Cooling upper limit output limiter' (Un\G521) is disabled even a value has been set.

■Two-position control

In the two-position control, this setting is disabled.

■Manual control

In the manual control, this setting is disabled.

When an output to an external device exceeds the upper limit output limiter value, the manipulated value (MV) of the manual control is fixed (clipped) to the set upper limit output limiter value.

■Default value

The default value is 1000 (100.0%).

CH1 Heating upper limit output limiter

Set the upper limit value for actually outputting the manipulated value for heating (MVh) calculated by the PID operation to an external device. In the auto tuning, this setting is ignored.

■Buffer memory address

The following shows the buffer memory address of this area.

Buffer memory area name	CH1	CH2	CH3	CH4
CH□ Heating upper limit output limiter	508	708	908	1108
CH□ Heating upper limit output limiter (in the Q compatible mode)	42	74	106	138

■Setting range

The setting range is 0 to 1050 (0.0 to 105.0%).

When a value out of the setting value is set, an out of setting range error (error code: 1950H) occurs. When an error has occurred, the following operations will be executed.

- 'Error flag' (X2) turns on.
- An error code is stored in 'Latest error code' (Un\G0).

Point

In the heating-cooling control, the lower limit value is not used. When 'CH1 Lower limit output limiter' (Un\G509) is set to a value other than 0, an out of setting range error (error code: 1950H) occurs.

■Two-position control

In the two-position control, this setting is disabled.

■Manual control

In the manual control, this setting is disabled.

■Default value

The default value is 1000 (100.0%).

CH1 Lower limit output limiter

Set the lower limit value for actually outputting the manipulated value (MV) calculated by the PID operation to an external device.

■Buffer memory address

The following shows the buffer memory address of this area.

Buffer memory area name	CH1	CH2	CH3	CH4
CH□ Lower limit output limiter	509	709	909	1109
CH□ Lower limit output limiter (in the Q compatible mode)	43	75	107	139

■Setting range

The setting range is -50 to 1050 (-5.0 to 105.0%).

Set values so that the lower limit output limiter value is smaller than the upper limit output limiter value.

When the lower limit output limiter value is equal to or greater than the upper limit output limiter value, CH□ Upper/lower limit output limiter setting error (error code: 1A0□H) occurs.

When a value out of the setting value is set, an out of setting range error (error code: 1950H) occurs. When an error has occurred, the following operations will be executed.

- 'Error flag' (X2) turns on.
- An error code is stored in 'Latest error code' (Un\G0).

■Two-position control

In the two-position control, this setting is disabled.

■Manual control

In the manual control, this setting is disabled.

When an output to an external device exceeds the lower limit output limiter value, the manipulated value (MV) of the manual control is fixed (clipped) to the set lower limit output limiter value.

■Default value

The default value is 0 (0.0%).

CH1 Output variation amount limiter

Set the limit of the output variation amount per 1s to regulate a rapid change of the manipulated value (MV).

■Buffer memory address

The following shows the buffer memory address of this area.

Buffer memory area name	CH1	CH2	CH3	CH4
CH□ Output variation amount limiter	510	710	910	1110
CH□ Output variation amount limiter (in the Q compatible mode)	44	76	108	140

■Setting range

The setting range is 0 or 1 to 1000 (0.1 to 100.0%/s). When 0 is set, the output variation amount is not regulated.

Ex.

When the following values have been set in the buffer memory areas

When 'CH1 Output variation amount limiter' (Un\G510) has been set to 10 (1.0%/s) and the sampling cycle is 500ms, an output value changes by 0.5% per 500ms. When the sampling cycle is 250ms, an output value changes by 0.2% or 0.3% per 250ms. Thus, even though the manipulated value (MV) rapidly changes by 50%, the variation amount is regulated to 1%/s. It takes 50s until the output actually changes by 50%.

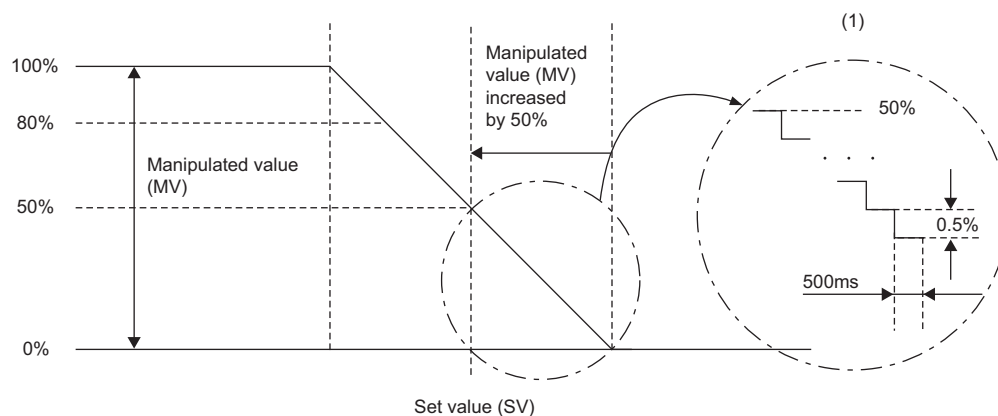

(1) When 'CH1 Output variation amount limiter' (Un\G510) has been set to 10 (1.0%/s)

■Two-position control

The setting is ignored.

■Manual control

The setting is enabled.

■At the execution of the auto tuning

The setting is enabled. However, when the output variation amount limiter setting is changed during the auto tuning, appropriate PID constants may not be calculated. Therefore, adjusting the output variation amount during the auto tuning is not recommended.

■Default value

The default value is 0.

CH1 Upper limit setting limiter

Set the upper limit value of the set value (SV).

■Buffer memory address

The following shows the buffer memory address of this area.

Buffer memory area name	CH1	CH2	CH3	CH4
CH□ Upper limit setting limiter	511	711	911	1111
CH□ Upper limit setting limiter (in the Q compatible mode)	55	87	119	151

■Setting range

The value is within the temperature measuring range set in 'CH1 Input range' (Un\G501). (☞ Page 247 CH1 Input range)
Configure the settings that satisfy the following conditions.

- 'CH1 Lower limit setting limiter' (Un\G512) < 'CH1 Upper limit setting limiter' (Un\G511)

When the above conditions are not satisfied, CH□ Upper/lower limit setting limiter error (error code: 1A1□H) occurs.

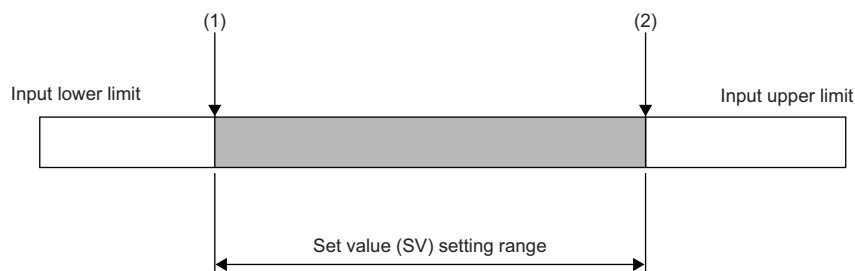

(1) 'CH1 Lower limit setting limiter' (Un\G512)

(2) 'CH1 Upper limit setting limiter' (Un\G511)

■Setting unit

The value to be set differs depending on the value stored in 'CH1 Decimal point position' (Un\G400). (☞ Page 223 CH1 Decimal point position)

- No decimal point (0): Set a value in increments of 1°C (or digit).
- First decimal place (1): Set a value (the value multiplied by 10) in increments of 0.1°C (°F).

■Default value

- For the R60TCTRT2TT2 and the R60TCTRT2TT2BW

The default value is 1300.

- For the R60TCRT4 and the R60TCRT4BW

The default value is 6000.

CH1 Lower limit setting limiter

Set the lower limit value of the set value (SV).

■Buffer memory address

The following shows the buffer memory address of this area.

Buffer memory area name	CH1	CH2	CH3	CH4
CH□ Lower limit setting limiter	512	712	912	1112
CH□ Lower limit setting limiter (in the Q compatible mode)	56	88	120	152

■Setting range

For the setting range, refer to the following.

☞ Page 259 Setting range

■Setting unit

For the setting unit, refer to the following.

☞ Page 259 Setting unit

■Default value

- For the R60TCTRT2TT2 and the R60TCTRT2TT2BW

The default value is 0.

- For the R60TCRT4 and the R60TCRT4BW

The default value is -2000.

CH1 Setting variation rate limiter/setting variation rate limiter (temperature rise)

Set the variation rate of the set value (SV) per a set unit time for when the set value (SV) is changed. This setting can regulate a rapid change of the manipulated value (MV).

Set a unit time in 'CH1 Setting variation rate limiter unit time setting' (Un\G526). (☞ Page 268 CH1 Setting variation rate limiter unit time setting)

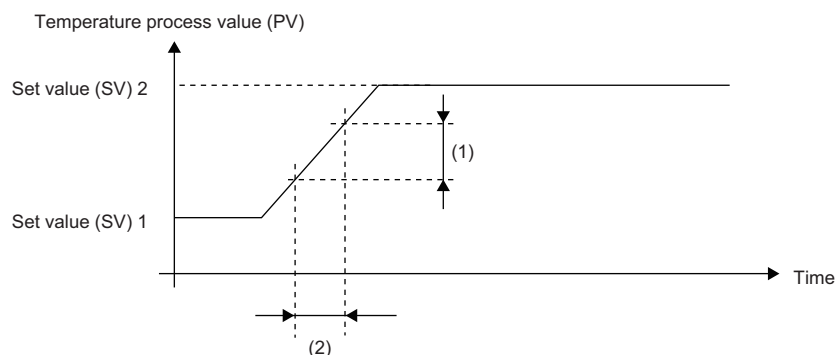

(1) Setting variation rate limiter (0 to the full scale of the input range (°C (°F)) (in the R mode), 0 to 100% of the full scale (in the Q compatible mode)

(2) 'CH1 Setting variation rate limiter unit time setting' (Un\G526)

■Buffer memory address

The following shows the buffer memory address of this area.

Buffer memory area name	CH1	CH2	CH3	CH4
CH□ Setting variation rate limiter/setting variation rate limiter (temperature rise)	513	713	913	1113
CH□ Setting variation rate limiter/setting variation rate limiter (temperature rise) (in the Q compatible mode)	52	84	116	148

■Temperature rise batch/individual setting

- In the R mode

Select whether to set the setting variation rate limiter in a batch or individually by setting 'Setting variation rate limiter setting selection' (Un\G303).

In the individual setting, this area is the setting for the temperature rise.

For details on the function, refer to the following.

☞ Page 55 Setting Variation Rate Limiter Setting Function

- In the Q compatible mode

Select whether to set the setting variation rate limiter in a batch or individually by setting 'Setting variation rate limiter setting selection' (in the Q compatible mode) (Un\G1024, b1).

In the individual setting, this area is the setting for the temperature rise.

For details on the function, refer to the following.

☞ Page 55 Setting Variation Rate Limiter Setting Function

■Setting range

- In the R mode

Set a value within the range of 0 to the full scale of the input range (°C (°F)). When 0 is set, this setting is disabled.

- In the Q compatible mode

Set 0 or a value within the range of 1 to 1000 (0.1 to 100.0%) to the full scale of the input range set in 'CH1 Input range' (Un\G501). When 0 is set, this setting is disabled.

■Default value

The default value is Disable (0).

CH1 Setting variation rate limiter (temperature drop)

This area is used when the individual setting has been selected with 'Automatic setting at input range change' (Un\G302) or 'Sampling cycle and function extension setting' (in the Q compatible mode) (Un\G1024).

■Buffer memory address

The following shows the buffer memory address of this area.

Buffer memory area name	CH1	CH2	CH3	CH4
CH□ Setting variation rate limiter (temperature drop)	514	714	914	1114
CH□ Setting variation rate limiter (temperature drop) (in the Q compatible mode)	564	596	628	660

■Setting range

- In the R mode

Set a value within the range of 0 to the full scale of the input range (°C (°F)). When 0 is set, this setting is disabled.

- In the Q compatible mode

Set 0 or a value within the range of 1 to 1000 (0.1 to 100.0%) to the full scale of the input range set in 'CH1 Input range' (Un\G501). When 0 is set, this setting is disabled.

■Default value

The default value is Disable (0).

CH1 Direct/reverse action setting

Select whether to use CH1 with direct actions or reverse actions.

Select direct actions for the cooling control. Select reverse actions for the heating control.

For details on the direct/reverse action selection function, refer to the following.

☞ Page 51 Direct/reverse Action Selection Function

■Buffer memory address

The following shows the buffer memory address of this area.

Buffer memory area name	CH1	CH2	CH3	CH4
CH□ Direct/reverse action setting	515	715	915	1115
CH□ Direct/reverse action setting (in the Q compatible mode)	54	86	118	150

■Setting range

- 0: Direct action
- 1: Reverse action

■Default value

The default value is Reverse action (1).

CH1 Adjustment sensitivity (dead band) setting

To prevent chattering of the transistor output in the two-position control, set the adjustment sensitivity (dead band) for the set value (SV).

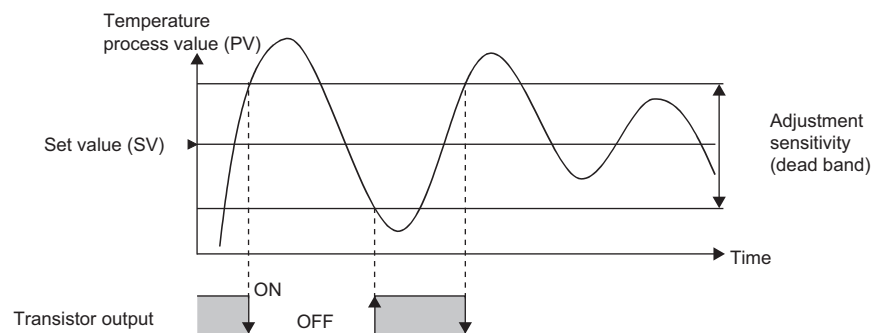

For details on the two-position control, refer to the following.

☞ Page 16 Control Method

■Buffer memory address

The following shows the buffer memory address of this area.

Buffer memory area name	CH1	CH2	CH3	CH4
CH□ Adjustment sensitivity (dead band) setting	516	716	916	1116
CH□ Adjustment sensitivity (dead band) setting (in the Q compatible mode)	46	78	110	142

■Setting range

- In the R mode
- 0 to the full scale of the input range (°C(°F))
- In the Q compatible mode

Set a value within the range of 1 to 100 (0.1 to 10.0%) to the full scale of the input range set in 'CH1 Input range' (Un\G501).

Ex.

When the following values have been set in the buffer memory areas

- 'CH1 Input range' (Un\G501): 38 (Temperature measuring range: -200.0°C to 400.0°C)
- 'CH1 Adjustment sensitivity (dead band) setting' (Un\G46): 10 (1.0%)

(Full scale) × (Adjustment sensitivity (dead band) setting) = (400.0°C - (-200.0°C)) × 0.01 = 6.0°C

The dead band is the set value (SV) ±3.0°C.

■Default value

- In the R mode
- For the R60TCRT2TT2 and the R60TCRT2TT2BW, the default value is 5 (5°C).
 For the R60TCRT4 and the R60TCRT4BW, the default value is 5 (0.5°C).

- In the Q compatible mode
- The default value is 5 (0.5%).

CH1 Manual reset amount setting

Set the travel amount of the proportional band (P). For details on the manual reset function, refer to the following.

☞ Page 29 Manual Reset Function

■Buffer memory address

The following shows the buffer memory address of this area.

Buffer memory area name	CH1	CH2	CH3	CH4
CH□ Manual reset amount setting	517	717	917	1117
CH□ Manual reset amount setting (in the Q compatible mode)	724	740	756	772

■Setting range

Set a value within the range of -1000 to 1000 (-100.0 to 100.0%).

The same setting range is applied to the standard control and heating-cooling control.

■Default value

The default value is 0 (0.0%). The same default value is applied to the standard control and the heating-cooling control.

CH1 AUTO/MAN mode shift

Select the value calculated by a PID operation as the manipulated value (MV) or set the manipulated value (MV) manually.

■Buffer memory address

The following shows the buffer memory address of this area.

Buffer memory area name	CH1	CH2	CH3	CH4
CH□ AUTO/MAN mode shift	518	718	918	1118
CH□ AUTO/MAN mode shift (in the Q compatible mode)	50	82	114	146

■Setting range

Setting value	Setting details	Description
0	AUTO	The AUTO (automatic) mode is activated. The manipulated value (MV) calculated by a PID operation is used for the calculation of the ON time of the control cycle.
1	MAN	The MAN (manual) mode is activated. The manipulated value (MV) written in 'CH1 MAN output setting' (Un\G519) is used for the calculation of the ON time of the control output cycle.

■When shifting the mode from the AUTO mode to the MAN mode

Execute the following operations.

- The manipulated value (MV) calculated by a PID operation is transferred to 'CH1 MAN output setting' (Un\G519).
(Operation to prevent a rapid change of the manipulated value (MV))
- After the mode is switched to the MAN mode, bits of 'MAN mode shift completion flag' (Un\G44) corresponding to the channels are set to Shift to MAN mode completed (1).

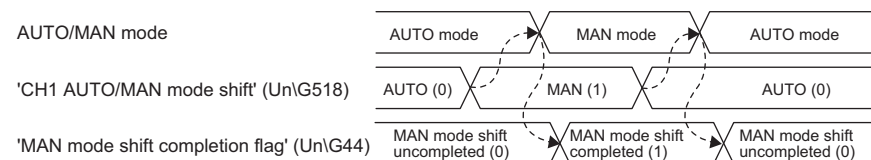

-----> Executed by the temperature control module

A



Set the manipulated value (MV) in the MAN mode after checking the completion of the mode shift processing.

■When executing the auto tuning

Set AUTO (0). When MAN (1) has been set, the auto tuning is not executed.

■Default value

The default value is AUTO (0).

CH1 MAN output setting

This buffer memory area is used to set the manipulated value (MV) in the MAN mode.

Even though writing of data is executed during control in the AUTO mode, the setting values do not change.

■Buffer memory address

The following shows the buffer memory address of this area.

Buffer memory area name	CH1	CH2	CH3	CH4
CH□ MAN output setting	519	719	919	1119
CH□ MAN output setting (in the Q compatible mode)	51	83	115	147

■How to shift the mode

Change the mode with the following buffer memory area.

- 'CH1 AUTO/MAN mode shift' (Un\G518) (☞ Page 263 CH1 AUTO/MAN mode shift)

■Setting range

The setting range differs depending on the standard control and the heating-cooling control. (☞ Page 14 Control Mode Selection Function)

- Standard control: -50 to 1050 (-5.0 to 105.0%)
- Heating-cooling control: -1050 to 1050 (-105.0 to 105.0%)

■Enabling the settings

Before writing a value in MAN output setting, check that the target bit of 'MAN mode shift completion flag' (Un\G44) is on. A value that has been written while MAN mode shift completion flag is off will be replaced with the manipulated value (MV) that the system calculated with the PID operation.

■Default value

The default value is 0 (0.0%).

Temperature conversion setting

In the heating-cooling control (normal mode), mix control (normal mode), or position-proportional control (normal mode), the temperature measurement and rate alarm can be executed using temperature input terminals of unused channels.

The following table lists the settable buffer memory addresses for each control mode selection.

Channel	Control mode						
	Standard control	Heating-cooling control (normal mode)	Heating-cooling control (expanded mode)	Mix control (normal mode)	Mix control (expanded mode)	Position-proportional control (normal mode)	Position-proportional control (expanded mode)
CH1	—	—	—	—	—	—	—
CH2	—	—	—	720	—	—	—
CH3	—	920	—	—	—	920	—
CH4	—	1120	—	—	—	1120	—

For the combination of the control mode and the buffer memory addresses not listed in the above table, setting values is disabled. For details on the temperature conversion function (using unused channels), refer to the following.

☞ Page 32 Temperature Conversion Function (Using Unused Channels)

■ Buffer memory address

The following shows the buffer memory address of this area.

Buffer memory area name	CH1	CH2	CH3	CH4
CH□ Temperature conversion setting	—	720	920	1120
CH□ Temperature conversion setting (in the Q compatible mode)	—	695	696	697

■ Setting range

- 0: Not used
- 1: Used

■ Default value

The default value is Not used (0).

Point

- When this setting is changed from Not used (0) to Used (1), 'Temperature conversion completion flag' (Un\G43) is set to First temperature conversion completed (1H) after the completion of the first temperature conversion. Before referring to the temperature process value (PV) of each channel, check 'Temperature conversion completion flag' (Un\G43) has been set to First temperature conversion completed (1H).
- When the standard control, heating-cooling control (expanded mode), mix control (expanded mode), or position-proportional control (expanded mode) has been selected, this setting is disabled.

CH1 Cooling upper limit output limiter

Set the upper limit value for actually outputting the manipulated value for cooling (MVc) calculated by the PID operation to an external device. In the auto tuning, this setting is ignored.

■ Buffer memory address

The following shows the buffer memory address of this area.

Buffer memory area name	CH1	CH2	CH3	CH4
CH□ Cooling upper limit output limiter	521	721	921	1121
CH□ Cooling upper limit output limiter (in the Q compatible mode)	721	737	753	769

■ Setting range

The setting range is 0 to 1050 (0.0 to 105.0%).

When a value out of the setting value is set, an out of setting range error (error code: 1950H) occurs. When an error has occurred, the following operations will be executed.

- 'Error flag' (X2) turns on.
- An error code is stored in 'Latest error code' (Un\G0).

Point

In the heating-cooling control, the lower limit value is not used. 'CH1 Lower limit output limiter' (Un\G509) is disabled even a value has been set.

■ Two-position control

In the two-position control, this setting is disabled.

■ Manual control

In the manual control, this setting is disabled.

■ Default value

The default value is 1000 (100.0%).

CH1 Cooling control output cycle setting

Set the pulse cycle (ON/OFF cycle) of the transistor output.

The ON time of the control output cycle is determined by multiplying the control output cycle by the manipulated value for cooling (MVC) (%) calculated by a PID operation. When the manipulated value for cooling (MVC) is stable, pulses are repeatedly output in the same cycle. For details on this area, refer to the following.

☞ Page 253 CH1 Control output cycle setting

■Buffer memory address

The following shows the buffer memory address of this area.

Buffer memory area name	CH1	CH2	CH3	CH4
CH□ Cooling control output cycle setting	522	722	922	1122
CH□ Cooling control output cycle setting (in the Q compatible mode)	722	738	754	770

CH1 Cooling method setting

Set a cooling control method in the heating-cooling control. Select a cooling method suitable for cooling characteristics of devices.

For details on the cooling method setting function, refer to the following.

☞ Page 31 Cooling Method Setting Function

■Buffer memory address

The following shows the buffer memory address of this area.

Buffer memory area name	CH1	CH2	CH3	CH4
CH□ Cooling method setting	523	723	923	1123

■Setting range

- 0H: Air cooling
- 1H: Water cooling
- 2H: Linear

■Enabling the settings

Turn on and off 'Setting change command' (YB) in the setting mode ('Setting/operation mode status' (X1): Off) to enable the settings.

■Default value

The default value is Air cooling (0H).

CH1 Cooling method setting [Q compatible mode]

Set a cooling control method in the heating-cooling control. Select a cooling method suitable for cooling characteristics of devices.

The following figure shows the channel assignment of this buffer memory area.

b15 to b12	b11 to b8	b7 to b4	b3 to b0
CH4	CH3	CH2	CH1

For details on the cooling method setting function, refer to the following.

☞ Page 31 Cooling Method Setting Function

■Buffer memory address

The following shows the buffer memory address of this area.

Buffer memory area name	CH1	CH2	CH3	CH4
CH□ Cooling method setting (in the Q compatible mode)	719			

■Setting range

- 0H: Air cooling
- 1H: Water cooling
- 2H: Linear

■Enabling the settings

Turn on and off 'Setting change command' (YB) in the setting mode ('Setting/operation mode status' (X1): Off) to enable the settings.

■Default value

The default value is Air cooling (0H).

CH1 Overlap/dead band setting

Configure the overlap/dead band setting. For details on the overlap/dead band function, refer to the following.

☞ Page 26 Overlap/dead Band Function

■Buffer memory address

The following shows the buffer memory address of this area.

Buffer memory area name	CH1	CH2	CH3	CH4
CH□ Overlap/dead band setting	524	724	924	1124
CH□ Overlap/dead band setting (in the Q compatible mode)	723	739	755	771

■Setting range

- In the R mode

Setting value	Description
-(Full scale of the input range) to -1	Overlap
0	None
1 to the full scale of the input range	Dead band

- In the Q compatible mode

Setting value	Description
-100 to -1 (-10.0 to -0.1%)	Overlap
0	None
1 to 100 (0.1 to 10.0%)	Dead band

■Default value

The default value is None (0).

CH1 Derivative action selection

Select the type of derivative action. Selecting a derivative action suitable for each of fixed value actions and ramp actions improves dynamic characteristics. For details on the derivative action selection function, refer to the following.

☞ Page 52 Derivative Action Selection Function

■Buffer memory address

The following shows the buffer memory address of this area.

Buffer memory area name	CH1	CH2	CH3	CH4
CH□ Derivative action selection	525	725	925	1125
CH□ Derivative action selection (in the Q compatible mode)	729	745	761	777

■Setting range

- 0: Measured value derivation
- 1: Deviation derivation

■Enabling the settings

Turn on and off 'Setting change command' (YB) in the setting mode ('Setting/operation mode status' (X1): Off) to enable the settings.

■Default value

The default value is Measured value derivation (0).

CH1 Setting variation rate limiter unit time setting

Set the unit time of the setting variation rate limiter. For details on the setting variation rate limiter setting function, refer to the following.

☞ Page 55 Setting Variation Rate Limiter Setting Function

■Buffer memory address

The following shows the buffer memory address of this area.

Buffer memory area name	CH1	CH2	CH3	CH4
CH□ Setting variation rate limiter unit time setting	526	726	926	1126
CH□ Setting variation rate limiter unit time setting (in the Q compatible mode)	735	751	767	783

■Setting range

- 0 (Unit time setting not used)
- 1 to 3600 (s)

When 0 has been set, the temperature control module operation is the same as the operation of when 60 (1 minute) has been set.

■Enabling the settings

Turn on and off 'Setting change command' (YB) in the setting mode ('Setting/operation mode status' (X1): Off) to enable the settings.

■Default value

The default value is 0 (unit time setting not used).

CH1 Open/close output neutral band setting

Set the output OFF area between the open side output and the close side output.

A neutral band is a value range where both of the open side output and the close side output are not on.

Repetitive outputs to the control motor due to frequent opening and closing can be prevented.

If the control motor is frequently opened and closed, set a larger value.

If the temperature fluctuates due to infrequent opening and closing, set a smaller value.

When the control operation result (ΔMV) exceeds the neutral band, output to the control motor starts.

Ex.

The following figure shows an ON timing example of open/close outputs when the control motor time is 100 seconds and the open/close output neutral band is 2.0%.

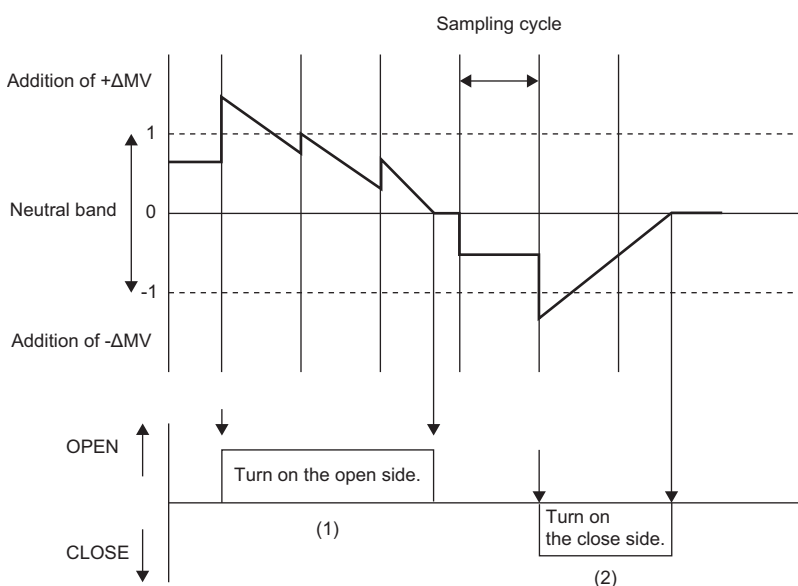

(1) When the operation result (ΔMV) is larger than 1, the open side output turns on.

(2) When the operation result (ΔMV) is smaller than -1, the close side output turns on.

■Buffer memory address

The following shows the buffer memory address of this area.

Buffer memory area name	CH1	CH2	CH3	CH4
CH□ Open/close output neutral band setting	527	727	927	1127
CH□ Open/close output neutral band setting (in the Q compatible mode)	1040	1056	1072	1088

■Setting range

1 to 100 (0.1 to 10.0%)

■Default value

The default value is 20 (2.0%).

CH1 Control motor time

Set the control motor rotation time from the full-open state to the full-closed state.

Check the specifications of the control motor used before setting a value.

■Buffer memory address

The following shows the buffer memory address of this area.

Buffer memory area name	CH1	CH2	CH3	CH4
CH□ Control motor time	528	728	928	1128
CH□ Control motor time (in the Q compatible mode)	1041	1057	1073	1089

■Setting range

The setting range is 5 to 1000 (s).

■Default value

The default value is 10 (s).

CH1 Integration output limiter setting

When one side output is continuously performed several times, each output ON time is integrated. If the integrated time exceeds the setting value, the output is turned off.

When the opposite side output is turned on while the one side output ON time is being integrated, the integrated value is reset.

Ex.

If the control is started in the full-closed state when 'CH1 Control motor time' (Un\G528) has been set to 10 (s) and 'CH1 Integration output limiter setting' (Un\G529) has been set to 1000 (100.0%), the operation is as follows.

The open side integrated value is expressed in the ratio of the open side output ON time to the control motor time.

Open side integrated value = (Open side output ON time) ÷ (Control motor time) × 100 (%)

The open side output is turned off when the open side integrated value equals to the integration output limiter setting.

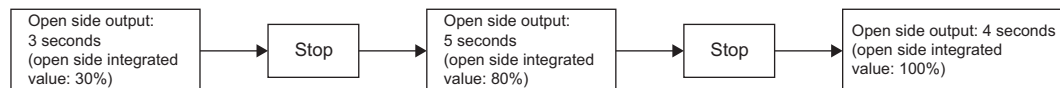

Ex.

When 'CH1 Control motor time' (Un\G528) has been set to 10 (s) and 'CH1 Integration output limiter setting' (Un\G529) has been set to 1000 (100.0%), the operation is as follows if the opposite side output (close side output) is turned on while the open side output ON time is being integrated.

The close side integrated value is expressed in the ratio of the close side output ON time to the control motor time.

Close side integrated value = (Close side output ON time) ÷ (Control motor time) × 100 (%)

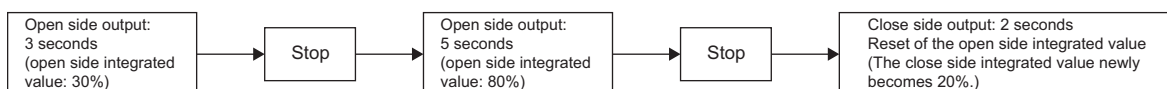

■Buffer memory address

The following shows the buffer memory address of this area.

Buffer memory area name	CH1	CH2	CH3	CH4
CH□ Integration output limiter setting	529	729	929	1129
CH□ Integration output limiter setting (in the Q compatible mode)	1042	1058	1074	1090

■Setting range

Set a value within the range of 0 to 2000 (0.0 to 200.0%) for the setting value of 'CH1 Control motor time' (Un\G528). (0.0: Integration output limiter function OFF)

■Default value

The default value is 1500 (150.0%).

CH1 Valve operation setting during CPU module STOP

Set the operation of the open side output and close side output of when the control stops (STOP).

■Buffer memory address

The following shows the buffer memory address of this area.

Buffer memory area name	CH1	CH2	CH3	CH4
CH□ Valve operation setting during CPU module STOP	530	730	930	1130
CH□ Valve operation setting during CPU module STOP (in the Q compatible mode)	1043	1059	1075	1091

■Setting range

- 0: Close side output OFF, open side output OFF
- 1: Close side output ON, open side output OFF
- 2: Close side output OFF, open side output ON

■Default value

The default value is Close side output OFF, open side output OFF (0).

CH1 Alert dead band setting

This setting is for using the alert function. For details on the alert function, refer to the following.

☞ Page 69 Alert Function

■Buffer memory address

The following shows the buffer memory address of this area.

Buffer memory area name	CH1	CH2	CH3	CH4
CH□ Alert dead band setting	531	731	931	1131
Alert dead band setting (in the Q compatible mode)	164			

■Setting range

- In the R mode

0 to the full scale of the input range (°C(°F))

Ex.

To set 6 (°C) as the dead band range when 'CH1 Input range' (Un\G501) is 2 (Temperature measuring range: 0°C to 1300°C), set 6 in 'CH1 Alert dead band setting' (Un\G531).

- In the Q compatible mode

Set a value within the range of 0 to 100 (0.0% to 10.0%) to the full scale of the set input range.

Ex.

When the following values have been set in the buffer memory areas

- 'CH1 Input range' (in the Q compatible mode) (Un\G32): 2 (Temperature measuring range: 0°C to 1300°C)
- 'Alert dead band setting' (in the Q compatible mode) (Un\G164): 5 (0.5%)

$(\text{Full scale}) \times (\text{Alert dead band}) = (1300^\circ\text{C} - 0^\circ\text{C}) \times 0.005 = 6.5^\circ\text{C}$

The dead band is the alert set value $\pm 6.5^\circ\text{C}$.

■Default value

The default value is 5.

A

CH1 Number of alert delay

Set the number of times to execute sampling to judge an alert.

By setting the number of times to execute sampling, when the temperature process value (PV) stays within the alert range after the temperature process value (PV) has entered the alert range until the number of times to execute sampling exceeds the number of alert delay, an alert occurs. For details on the alert function, refer to the following.

 Page 69 Alert Function

■Buffer memory address

The following shows the buffer memory address of this area.

Buffer memory area name	CH1	CH2	CH3	CH4
CH□ Number of alert delay	532	732	932	1132
Number of alert delay (in the Q compatible mode)	165			

■Setting range

- In the R mode

The setting range is 0 to 30000 (times).

- In the Q compatible mode

The setting range is 0 to 255 (times).

Point

When 0 (times) has been set, an alert occurs as soon as the temperature process value (PV) goes within the alert range.

■Default value

The default value is 0 (times).

CH1 Alert 1 mode setting

Set the alert mode of Alert 1. For details on the alert function, refer to the following.

 Page 69 Alert Function

■Buffer memory address

The following shows the buffer memory address of this area.

Buffer memory area name	CH1	CH2	CH3	CH4
CH□ Alert 1 mode setting	533	733	933	1133
CH□ Alert 1 mode setting (in the Q compatible mode)	192	208	224	240

Point

This area is disabled for the following modes and channels.

- Heating-cooling control (normal mode), position-proportional control (normal mode): CH3, CH4
- Mix control (normal mode): CH2

■Alert mode and alert set value

Set an alert set value for the alert mode of Alert 1 selected in this setting. Set a value in 'CH1 Alert set value 1' (Un\G434). 'CH1 Alert set value 1' (Un\G434) corresponds to the alert mode of Alert 1.

■Setting range

The following table lists setting values and setting ranges of alert set values in each alert mode.

Setting value	Alert mode	Setting range of Alert set value
0	— (No alert)	—
1	Upper limit input alert	Value within the temperature measuring range of the set input range
2	Lower limit input alert	
3	Upper limit deviation alert	(-(Full scale)) to Full scale
4	Lower limit deviation alert	
5	Upper/lower limit deviation alert	0 to Full scale
6	Within-range alert	
7	Upper limit input alert with standby	Value within the temperature measuring range of the set input range
8	Lower limit input alert with standby	
9	Upper limit deviation alert with standby	(-(Full scale)) to Full scale
10	Lower limit deviation alert with standby	
11	Upper/lower limit deviation alert with standby	0 to Full scale
12	Upper limit deviation alert with standby (second time)	
13	Lower limit deviation alert with standby (second time)	(-(Full scale)) to Full scale
14	Upper/lower limit deviation alert with standby (second time)	
15	Upper limit deviation alert (set value (SV) used)	(-(Full scale)) to Full scale
16	Lower limit deviation alert (set value (SV) used)	
17	Upper/lower limit deviation alert (set value (SV) used)	0 to Full scale
18	Within-range alert (set value (SV) used)	
19	Upper limit deviation alert with standby (set value (SV) used)	(-(Full scale)) to Full scale
20	Lower limit deviation alert with standby (set value (SV) used)	
21	Upper/lower limit deviation alert with standby (set value (SV) used)	0 to Full scale
22	Upper limit deviation alert with standby (second time) (set value (SV) used)	
23	Lower limit deviation alert with standby (second time) (set value (SV) used)	(-(Full scale)) to Full scale
24	Upper/lower limit deviation alert with standby (second time) (set value (SV) used)	

■Enabling the settings

Turn on and off 'Setting change command' (YB) in the setting mode ('Setting/operation mode status' (X1): Off) to enable the settings.

When a value out of the setting value is set, an out of setting range error (error code: 1950H) occurs and the temperature control module operates with the previous values.

Turning on and off 'Setting change command' (YB) after the occurrence of an error and setting a value within the range operate the temperature control module with the new set value.

■Default value

The default value is 0.

CH1 Alert 2 mode setting

Set the alert mode of Alert 2. For details on the alert function, refer to the following.

 Page 69 Alert Function

■Buffer memory address

The following shows the buffer memory address of this area.

Buffer memory area name	CH1	CH2	CH3	CH4
CH□ Alert 2 mode setting	534	734	934	1134
CH□ Alert 2 mode setting (in the Q compatible mode)	193	209	225	241

Point

This area is disabled for the following modes and channels.

- Heating-cooling control (normal mode), position-proportional control (normal mode): CH3, CH4
- Mix control (normal mode): CH2

■Alert mode and alert set value

Set an alert set value for the alert mode of Alert 2 selected in this setting. Set a value in 'CH1 Alert set value 2' (Un\G435). 'CH1 Alert set value 2' (Un\G434) corresponds to the alert mode of Alert 2.

■Setting range

For the setting range, refer to the following in CH1 Alert 1 mode setting.

 Page 273 Setting range

■Enabling the settings

For enabling the settings, refer to the following in CH1 Alert 1 mode setting.

 Page 273 Enabling the settings

■Default value

For the default value, refer to the following in CH1 Alert 1 mode setting.

 Page 273 Default value

CH1 Alert 3 mode setting

Set the alert mode of Alert 3. For details on the alert function, refer to the following.

 Page 69 Alert Function

■Buffer memory address

The following shows the buffer memory address of this area.

Buffer memory area name	CH1	CH2	CH3	CH4
CH□ Alert 3 mode setting	535	735	935	1135
CH□ Alert 3 mode setting (in the Q compatible mode)	194	210	226	242

Point

This area is disabled for the following modes and channels.

- Heating-cooling control (normal mode), position-proportional control (normal mode): CH3, CH4
- Mix control (normal mode): CH2

■Alert mode and alert set value

Set an alert set value for the alert mode of Alert 3 selected in this setting. Set a value in 'CH1 Alert set value 3' (Un\G436). 'CH1 Alert set value 3' (Un\G436) corresponds to the alert mode of Alert 3.

■Setting range

For the setting range, refer to the following in CH1 Alert 1 mode setting.

 Page 273 Setting range

■Enabling the settings

For enabling the settings, refer to the following in CH1 Alert 1 mode setting.

☞ Page 273 Enabling the settings

■Default value

For the default value, refer to the following in CH1 Alert 1 mode setting.

☞ Page 273 Default value

CH1 Alert 4 mode setting

Set the alert mode of Alert 4. For details on the alert function, refer to the following.

☞ Page 69 Alert Function

■Buffer memory address

The following shows the buffer memory address of this area.

Buffer memory area name	CH1	CH2	CH3	CH4
CH□ Alert 4 mode setting	536	736	936	1136
CH□ Alert 4 mode setting (in the Q compatible mode)	195	211	227	243

Point

This area is disabled for the following modes and channels.

- Heating-cooling control (normal mode), position-proportional control (normal mode): CH3, CH4
- Mix control (normal mode): CH2

■Alert mode and alert set value

Set an alert set value for the alert mode of Alert 4 selected in this setting. Set a value in 'CH1 Alert set value 4' (Un\G437).

'CH1 Alert set value 4' (Un\G437) corresponds to the alert mode of Alert 4.

■Setting range

For the setting range, refer to the following in CH1 Alert 1 mode setting.

☞ Page 273 Setting range

■Enabling the settings

For enabling the settings, refer to the following in CH1 Alert 1 mode setting.

☞ Page 273 Enabling the settings

■Default value

For the default value, refer to the following in CH1 Alert 1 mode setting.

☞ Page 273 Default value

CH1 Loop disconnection detection judgment time

The loop disconnection detection function detects errors such as disconnections of resistors, malfunction of an externally-operable device, and errors of the control system due to troubles such as disconnection of a sensor. When the temperature does not change by 2°C (°F) or higher within the loop disconnection detection judgment time, this function judges it as a loop disconnection. For details on the loop disconnection detection function, refer to the following.

☞ Page 88 Loop Disconnection Detection Function

■Buffer memory address

The following shows the buffer memory address of this area.

Buffer memory area name	CH1	CH2	CH3	CH4
CH□ Loop disconnection detection judgment time	537	737	937	1137
CH□ Loop disconnection detection judgment time (in the Q compatible mode)	59	91	123	155

■Setting range

The setting range is 0 to 7200 (s).

Set a value greater than the time taken for the temperature to change by 2°C (°F).

■When executing the auto tuning

A value that is twice as large as the value in 'CH1 Integral time (I) setting' (Un\G432) is automatically set in this setting. However, when this setting has been set to 0 (s) at the start of the auto tuning, the loop disconnection detection judgment time is not stored.

■Default value

The default value is 480 (s).

CH1 Loop disconnection detection dead band

Set the non-alert area having the set value (SV) at the center (temperature width in which no loop disconnection is detected) to prevent accidental alerts of the loop disconnection detection.

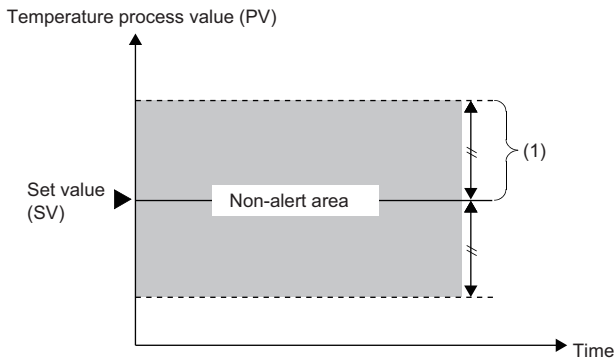

(1) 'CH1 Loop disconnection detection dead band' (Un\G538) (this band has the set value (SV) at the center.)

For details on the loop disconnection detection function, refer to the following.

☞ Page 88 Loop Disconnection Detection Function

■Buffer memory address

The following shows the buffer memory address of this area.

Buffer memory area name	CH1	CH2	CH3	CH4
CH□ Loop disconnection detection dead band	538	738	938	1138
CH□ Loop disconnection detection dead band (in the Q compatible mode)	60	92	124	156

■Setting range

Input range

Ex.

When the following values have been set in the buffer memory areas

- 'CH1 Input range' (Un\G501): 38 (Resolution: 0.1)
- 'CH1 Loop disconnection detection dead band' (Un\G538): 50

(Loop disconnection detection dead band setting value) × (Resolution) = 50 × 0.1 = 5.0°C

Within the range of the set value (SV) ±5.0°C, the loop disconnection detection judgment is not executed.

■Setting unit

The value to be set differs depending on the value stored in 'CH1 Decimal point position' (Un\G400).

- No decimal point (0): Set a value in increments of 1°C (°F or digit).
- First decimal place (1): Set a value (the value multiplied by 10) in increments of 0.1°C (°F).

■Default value

The default value is 0.

CH1 Rate alarm alert output enable/disable setting

Set whether to enable or disable alert output of rate alarms. For details on rate alarms, refer to the following.

☞ Page 79 Rate Alarm Function

■Buffer memory address

The following shows the buffer memory address of this area.

Buffer memory area name	CH1	CH2	CH3	CH4
CH□ Rate alarm alert output enable/disable setting	539	739	939	1139
CH□ Rate alarm alert output enable/disable setting (in the Q compatible mode)	201	217	233	249

■Setting range

- 0: Enable
- 1: Disable

■Enabling the settings

Turn on and off 'Setting change command' (YB) in the setting mode ('Setting/operation mode status' (X1): Off) to enable the settings.

■Default value

The default value is Disable (1).

CH1 Rate alarm alert detection cycle

Set the checking cycle of the temperature process value (PV) at the occurrence of a rate alarm. Set the frequency of checks in increments of sampling cycles. The checking cycle can be calculated by the following formula.

- Rate alarm alert detection cycle = Set value of Rate alarm alert detection cycle × Sampling cycle

■Buffer memory address

The following shows the buffer memory address of this area.

Buffer memory area name	CH1	CH2	CH3	CH4
CH□ Rate alarm alert detection cycle	540	740	940	1140
CH□ Rate alarm alert detection cycle (in the Q compatible mode)	202	218	234	250

■Setting range

The setting range is 1 to 6000 (times).

■Enabling the settings

Turn on and off 'Setting change command' (YB) in the setting mode ('Setting/operation mode status' (X1): Off) to enable the settings.

■Default value

The default value is 1 (check the value every sampling cycle).

CH1 Rate alarm upper limit value

Set the rate alarm upper limit value.

■Buffer memory address

The following shows the buffer memory address of this area.

Buffer memory area name	CH1	CH2	CH3	CH4
CH□ Rate alarm upper limit value	541	741	941	1141
CH□ Rate alarm upper limit value (in the Q compatible mode)	203	219	235	251

■Setting range

The setting range is -32768 to 32767.

■Setting unit

The value to be set differs depending on the value stored in 'CH1 Decimal point position' (Un\G400).

- No decimal point (0): Set a value in increments of 1°C (°F or digit).
- First decimal place (1): Set a value (the value multiplied by 10) in increments of 0.1°C (°F).

■Enabling the settings

Turn on and off 'Setting change command' (YB) in the setting mode ('Setting/operation mode status' (X1): Off) to enable the settings.

■Default value

The default value is 0.

CH1 Rate alarm lower limit value

Set the rate alarm lower limit value. For details on this area, refer to the following.

☞ Page 277 CH1 Rate alarm upper limit value

■Buffer memory address

The following shows the buffer memory address of this area.

Buffer memory area name	CH1	CH2	CH3	CH4
CH□ Rate alarm lower limit value	542	742	942	1142
CH□ Rate alarm lower limit value (in the Q compatible mode)	204	220	236	252

CH1 Auto tuning mode selection

Select one of the following two auto tuning modes depending on the controlled object to be used.

Auto tuning	Description
Standard mode	The standard mode is appropriate for most controlled objects. This mode is especially suitable for controlled objects that have an extremely slow response or can be affected by noise or disturbance. However, PID constants with a slow response (low gain) may be calculated from the controlled objects whose ON time or OFF time during the auto tuning is only around 10s. In this case, PID constants with a fast response can be calculated by selecting the high response mode and executing the auto tuning.
High response mode	This mode is suitable for controlled objects whose ON time or OFF time during the auto tuning is only around 10s. PID constants with a fast response (high gain) can be calculated. However, the temperature process value (PV) may oscillates near the set value (SV) because of the too high gain of the PID constants calculated. In this case, select the standard mode and execute the auto tuning.

For details on the auto tuning function, refer to the following.

☞ Page 35 Auto Tuning Function

■Buffer memory address

The following shows the buffer memory address of this area.

Buffer memory area name	CH1	CH2	CH3	CH4
CH□ Auto tuning mode selection	543	743	943	1143
CH□ Auto tuning mode selection (in the Q compatible mode)	184	185	186	187

■Setting range

- 0: Standard mode
- 1: High response mode

■Default value

The default value is Standard mode (0).

CH1 Auto tuning error judgment time

When the time taken for the process value (PV) in the auto tuning to exceed the set value (SV) exceeds the auto tuning abnormal end judgment time, the function judges it as an error and ends the auto tuning.

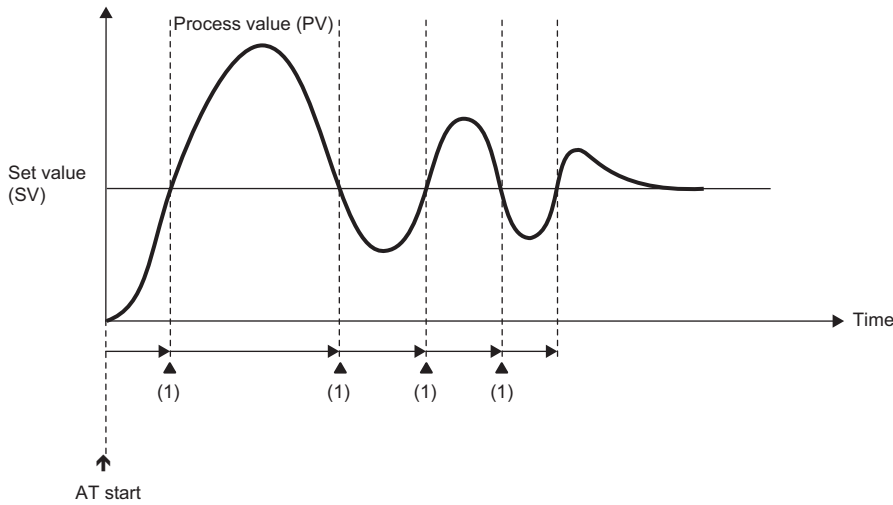

(1) When the process value (PV) exceeds the set value (SV), the elapsed time is cleared and monitoring continues.

■ Buffer memory address

The following shows the buffer memory address of this area.

Buffer memory area name	CH1	CH2	CH3	CH4
CH□ Auto tuning error judgment time	544	744	944	1144
CH□ Auto tuning error judgment time (in the Q compatible mode)	1049	1065	1081	1097

■ Setting range

The setting range is 1 to 120 (min).

■ Default value

The default value is 120 (min).

CH1 During AT loop disconnection detection function enable/disable

Set whether to enable or disable the loop disconnection detection function during auto tuning (AT).

For details on the during AT loop disconnection detection function, refer to the following.

☞ Page 90 During AT Loop Disconnection Detection Function

■ Buffer memory address

The following shows the buffer memory address of this area.

Buffer memory area name	CH1	CH2	CH3	CH4
CH□ During AT loop disconnection detection function enable/disable	545	745	945	1145

■ Setting range

- 0: Disable
- 1: Enable

■ Default value

The default value is Disable (0).

During AT loop disconnection detection function enable/disable [Q compatible mode]

In the Q compatible mode, set whether to enable or disable the loop disconnection detection function during auto tuning (AT). For details on the during AT loop disconnection detection function, refer to the following.

 Page 90 During AT Loop Disconnection Detection Function

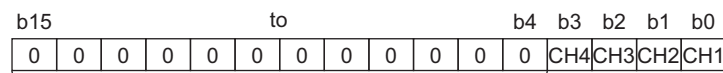

Bit data from b15 to b4 are fixed to 0.

■Buffer memory address

The following shows the buffer memory address of this area.

Buffer memory area name	CH1	CH2	CH3	CH4
During AT loop disconnection detection function enable/disable (in the Q compatible mode)	571			

■Setting range

- 0: Disable
- 1: Enable

■Default value

The default value is Disable (0).

CH1 AT bias

The point set as the set value (SV) of the auto tuning can be rearranged by using this area.

The auto tuning function determines each PID constant by executing the two-position control toward the set value (SV) and causing hunting of the temperature process value (PV).

Set 'CH1 AT bias' (Un\G546) when an overshoot caused by the hunting is improper or the process value (PV) exceeds the set value (SV) during the auto tuning.

The auto tuning is executed with having the AT point (the point rearranged by the setting) as its center.

When the auto tuning is completed, AT bias is not added and a control is executed toward the set value (SV). For details on the auto tuning function, refer to the following.

 Page 35 Auto Tuning Function

Ex.

When a negative value has been set for AT bias (reverse action)

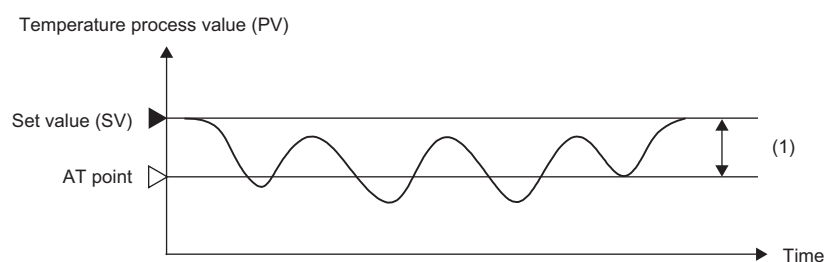

(1) 'CH1 AT bias' (Un\G546)

■Buffer memory address

The following shows the buffer memory address of this area.

Buffer memory area name	CH1	CH2	CH3	CH4
CH□ AT bias	546	746	946	1146
CH□ AT bias (in the Q compatible mode)	53	85	117	149

■Setting range

The setting range is (-Full scale) to Full scale. The setting range depends on the setting of 'CH1 Input range' (Un\G501).

Ex.

When the following values have been set in the buffer memory areas

- 'CH1 Input range' (Un\G501): 38 (Temperature measuring range: -200.0°C to 400.0°C, resolution: 0.1)

The setting range is -6000 to 6000.

■Setting unit

The value to be set differs depending on the value stored in 'CH1 Decimal point position' (Un\G400).

- No decimal point (0): Set a value in increments of 1°C (°F or digit).
- First decimal place (1): Set a value (the value multiplied by 10) in increments of 0.1°C (°F).

■Default value

The default value is 0.

■Precautions

For 'CH1 AT bias' (Un\G546), set a range in which a PID operation fluctuates slightly and control results get no effect. Depending on the controlled object used, accurate PID constants may not be obtained.

CH1 Automatic backup setting after auto tuning of PID constants

This function automatically backs up the setting values stored in buffer memory areas at the completion of the auto tuning into the non-volatile memory. By reading the set values backed up, when the power is turned off and on or the CPU module is reset and the reset is cleared, another auto tuning can be omitted.

For details on the auto tuning function, refer to the following.

 Page 35 Auto Tuning Function

■Buffer memory address

The following shows the buffer memory address of this area.

Buffer memory area name	CH1	CH2	CH3	CH4
CH□ Automatic backup setting after auto tuning of PID constants	547	747	947	1147
CH□ Automatic backup setting after auto tuning of PID constants (in the Q compatible mode)	63	95	127	159

■Buffer memory areas from which set values are backed up to the non-volatile memory

The following table lists the buffer memory areas whose values are backed up.

Buffer memory area name	Buffer memory address	Reference
CH1 Proportional band (P) setting	Un\G431	Page 238 CH1 Proportional band (P) setting
CH1 Heating proportional band (Ph) setting	Un\G431	Page 240 CH1 Heating proportional band (Ph) setting
CH1 Cooling proportional band (Pc) setting	Un\G439	Page 244 CH1 Cooling proportional band (Pc) setting
CH1 Integral time (I) setting	Un\G432	Page 240 CH1 Integral time (I) setting
CH1 Derivative time (D) setting	Un\G433	Page 241 CH1 Derivative time (D) setting
CH1 Loop disconnection detection judgment time	Un\G537	Page 275 CH1 Loop disconnection detection judgment time

■Setting range



- 0: Disable
- 1: Enable

■Default value

The default value is Disable (0).

■Precautions

When this command has been set to Enable (1), do not execute the following operations. An incorrect value may be stored in the non-volatile memory.

- Changing a set value in a buffer memory area
- Memory backup ( Page 119 Buffer Memory Data Backup Function)
- Default setting registration ( Page 159 Default setting registration command)
- Changing the value to Disable (0) during the auto tuning

CH1 Self-tuning setting

Set an operation of the self-tuning in this area.

For details on the self-tuning function, refer to the following.

 Page 44 Self-tuning Function

■Buffer memory address

The following shows the buffer memory address of this area.

Buffer memory area name	CH1	CH2	CH3	CH4
CH□ Self-tuning setting	548	748	948	1148
CH□ Self-tuning setting (in the Q compatible mode)	574	606	638	670

■Setting range

- 0: Do not execute ST
- 1: Starting ST (Only PID constants are calculated.)
- 2: Starting ST (Only simultaneous temperature rise parameters*¹ are calculated.)
- 3: Starting ST (PID constants and simultaneous temperature rise parameters*¹ are calculated.)
- 4: Starting ST + Vibration (Only PID constants are calculated for both.)

*¹ The values of 'CH1 Simultaneous temperature rise gradient data' (Un\G554) and 'CH1 Simultaneous temperature rise dead time' (Un\G555) used by the simultaneous temperature rise function

For details on the simultaneous temperature rise function, refer to the following.

 Page 97 Simultaneous Temperature Rise Function

■Default value

The default value is Do not execute ST (0).



This area is enabled only for the following channels.

- CH1 to CH4 of when the standard control is used
- CH3 and CH4 of when the mix control (normal mode) or mix control (expanded mode) is used

CH1 Process value (PV) scaling function enable/disable setting

Set whether to enable or disable the temperature process value (PV) scaling function. For details on the temperature process value (PV) scaling function, refer to the following.

 Page 65 Scaling Function

■Buffer memory address

The following shows the buffer memory address of this area.

Buffer memory area name	CH1	CH2	CH3	CH4
CH□ Process value (PV) scaling function enable/disable setting	549	749	949	1149
CH□ Process value (PV) scaling function enable/disable setting (in the Q compatible mode)	725	741	757	773

■Setting range

- 0: Disable
- 1: Enable

■Enabling the settings

Turn on and off 'Setting change command' (YB) in the setting mode ('Setting/operation mode status' (X1): Off) to enable the settings.

■Default value

The default value is Disable (0).

CH1 Process value (PV) scaling upper limit value

Set the upper limit value of the temperature process value (PV) scaling function. For details on the temperature process value (PV) scaling function, refer to the following.

 Page 65 Scaling Function

■Buffer memory address

The following shows the buffer memory address of this area.

Buffer memory area name	CH1	CH2	CH3	CH4
CH□ Process value (PV) scaling upper limit value	550	750	950	1150
CH□ Process value (PV) scaling upper limit value (in the Q compatible mode)	727	743	759	775

■Setting range

The setting range is -32000 to 32000.

■Enabling the settings

Turn on and off 'Setting change command' (YB) in the setting mode ('Setting/operation mode status' (X1): Off) to enable the settings.

■Default value

The default value is 0.

A

Point

Even though values are set so that the lower limit value is equal to or greater than the upper limit value, no error occurs. Scaling is executed according to the following formula.

 Page 65 Monitoring the scaling value

CH1 Process value (PV) scaling lower limit value

Set the lower limit value of the temperature process value (PV) scaling function. For details on the temperature process value (PV) scaling function, refer to the following.

 Page 65 Scaling Function

■Buffer memory address

The following shows the buffer memory address of this area.

Buffer memory area name	CH1	CH2	CH3	CH4
CH□ Process value (PV) scaling lower limit value	551	751	951	1151
CH□ Process value (PV) scaling lower limit value (in the Q compatible mode)	726	742	758	774

■Setting range

For the setting range, refer to the following.

 Page 283 Setting range

■Enabling the settings

For how to enable the settings, refer to the following.

☞ Page 283 Enabling the settings

■Default value

For the default value, refer to the following.

☞ Page 283 Default value

Point

Even though values are set so that the lower limit value is equal to or greater than the upper limit value, no error occurs. Scaling is executed according to the following formula.

☞ Page 65 Monitoring the scaling value

CH1 Peak current suppression control group setting

Set the target channel of the peak current suppression function and the width of the control output cycle to be shifted for each channel.

For details on the peak current suppression function, refer to the following.

☞ Page 92 Peak Current Suppression Function

When the inter-module peak current suppression function has been enabled, up to 5 groups can be set.

■Buffer memory address

The following shows the buffer memory address of this area.

Buffer memory area name	CH1	CH2	CH3	CH4
CH□ Peak current suppression control group setting	552	752	952	1152

■Setting range

- 0: Not divided
- 1: 1 group
- 2: 2 groups
- 3: 3 groups
- 4: 4 groups
- 5: 5 groups (when the inter-module peak current suppression function is enabled)

■Enabling the settings

Turn on and off 'Setting change command' (YB) in the setting mode ('Setting/operation mode status' (X1): Off) to enable the settings.

■Default value

The default value is Not divided (0H).

Peak current suppression control group setting [Q compatible mode]

In the Q compatible mode, set the target channel of the peak current suppression function and the width of the control output cycle to be shifted for each channel.

For details on the peak current suppression function, refer to the following.

☞ Page 92 Peak Current Suppression Function

When the inter-module peak current suppression function has been enabled, up to 5 groups can be set.

b15 to b12	b11 to b8	b7 to b4	b3 to b0
CH4	CH3	CH2	CH1

■Buffer memory address

The following shows the buffer memory address of this area.

Buffer memory area name	CH1	CH2	CH3	CH4
Peak current suppression control group setting [in the Q compatible mode]	784			

■Setting range

- 0: Not divided
- 1: 1 group
- 2: 2 groups
- 3: 3 groups
- 4: 4 groups
- 5: 5 groups (when the inter-module peak current suppression function is enabled)

■Number of divisions

The number of divisions is determined by this setting. The upper limit output limiter value is automatically set depending on the set number of divisions. At the timing of when this setting is enabled, the following values are set.

Number of divisions	'CH1 Upper limit output limiter' (in the Q compatible mode) (Un\G42)
2	500 (50.0%)
3	333 (33.3%)
4	250 (25.0%)
5	200 (20.0%)

'CH1 Lower limit output limiter' (in the Q compatible mode) (Un\G43) is set to 0.

■Enabling the settings

Turn on and off 'Setting change command' (YB) in the setting mode ('Setting/operation mode status' (X1): Off) to enable the settings.

■Default value

The default value is Not divided (0H).

A

CH1 Simultaneous temperature rise group setting

Set a group to execute the simultaneous temperature rise for each channel. The simultaneous temperature rise function adjusts the simultaneous temperature rise completion time of the channels in the same group. When the control mode is the heating-cooling control or position-proportional control, this setting is ignored. For details on the simultaneous temperature rise function, refer to the following.

 Page 97 Simultaneous Temperature Rise Function

■Buffer memory address

The following shows the buffer memory address of this area.

Buffer memory area name	CH1	CH2	CH3	CH4
CH□ Simultaneous temperature rise group setting	553	753	953	1153
CH□ Simultaneous temperature rise group setting (in the Q compatible mode)	730	746	762	778

■Setting range for the standard control

- 0: No simultaneous temperature rise
- 1: Group 1 selection
- 2: Group 2 selection

■Setting range for the mix control (only CH3 and CH4)

- 0: No simultaneous temperature rise
- 1: Simultaneous temperature rise

■Setting range for the standard control (when the inter-module simultaneous temperature rise function is enabled)

- 0: No simultaneous temperature rise
- 1: Group 1 selection
- 2: Group 2 selection
- 3: Group 3 selection
- 4: Group 4 selection
- 5: Group 5 selection
- 6: Group 6 selection
- 7: Group 7 selection
- 8: Group 8 selection
- 9: Group 9 selection
- 10: Group 10 selection
- 11: Group 11 selection
- 12: Group 12 selection
- 13: Group 13 selection
- 14: Group 14 selection
- 15: Group 15 selection
- 16: Group 16 selection

■Setting range for the mix control (when the inter-module simultaneous temperature rise function is enabled) (only CH3 and CH4)

- 0: No simultaneous temperature rise
- 1: Group 1 selection
- 2: Group 2 selection
- 3: Group 3 selection
- 4: Group 4 selection
- 5: Group 5 selection
- 6: Group 6 selection
- 7: Group 7 selection
- 8: Group 8 selection
- 9: Group 9 selection
- 10: Group 10 selection
- 11: Group 11 selection
- 12: Group 12 selection
- 13: Group 13 selection
- 14: Group 14 selection
- 15: Group 15 selection
- 16: Group 16 selection

■Enabling the settings

Turn on and off 'Setting change command' (YB) in the setting mode ('Setting/operation mode status' (X1): Off) to enable the settings.

■Default value

The default value is No simultaneous temperature rise (0).

CH1 Simultaneous temperature rise gradient data

Set simultaneous temperature rise gradient data (temperature rise per minute). For details on the simultaneous temperature rise function, refer to the following.

 Page 97 Simultaneous Temperature Rise Function

■ Buffer memory address

The following shows the buffer memory address of this area.

Buffer memory area name	CH1	CH2	CH3	CH4
CH□ Simultaneous temperature rise gradient data	554	754	954	1154
CH□ Simultaneous temperature rise gradient data (in the Q compatible mode)	731	747	763	779

■ Setting range

The setting range is 0 to the full scale of the input range.

■ Default value

The default value is 0.

Point

This setting can be set manually and calculated automatically. Automatic calculation is executed when the simultaneous temperature rise AT (auto tuning) or self-tuning (when the calculation of the simultaneous temperature rise parameter has been set) is completed successfully.

CH1 Simultaneous temperature rise dead time

Set the simultaneous temperature rise dead time (time taken for the temperature to start rising after the output is turned on). For details on the simultaneous temperature rise function, refer to the following.

 Page 97 Simultaneous Temperature Rise Function

■ Buffer memory address

The following shows the buffer memory address of this area.

Buffer memory area name	CH1	CH2	CH3	CH4
CH□ Simultaneous temperature rise dead time	555	755	955	1155
CH□ Simultaneous temperature rise dead time (in the Q compatible mode)	732	748	764	780

■ Setting range

The setting range is 0 to 3600 (s).

■ Default value

The default value is 0.

Point

This setting can be set manually and calculated automatically. Automatic calculation is executed when the simultaneous temperature rise AT (auto tuning) or self-tuning (when the calculation of the simultaneous temperature rise parameter has been set) is completed successfully.

CH1 Simultaneous temperature rise AT mode selection

Select an auto tuning mode.

For details on the auto tuning function, refer to the following.

☞ Page 35 Auto Tuning Function

For details on the simultaneous temperature rise function, refer to the following.

☞ Page 97 Simultaneous Temperature Rise Function

■ Buffer memory address

The following shows the buffer memory address of this area.

Buffer memory area name	CH1	CH2	CH3	CH4
CH□ Simultaneous temperature rise AT mode selection	556	756	956	1156
CH□ Simultaneous temperature rise AT mode selection (in the Q compatible mode)	733	749	765	781

■ Setting range

- 0: Select normal auto tuning
- 1: Select simultaneous temperature rise AT

■ Default value

The default value is Select normal auto tuning (0).



- This setting can be used with the setting of 'CH1 Auto tuning mode selection' (Un\G543).
- When this setting is changed during the auto tuning, the setting will be enabled in the next auto tuning.

CH1 Disturbance judgment position

Set the deviation to detect disturbance.

The disturbance suppression function starts when the deviation (difference between the set value (SV) and process value (PV)) exceeds the set value.

Ex.

When the disturbance judgment position is -5°C

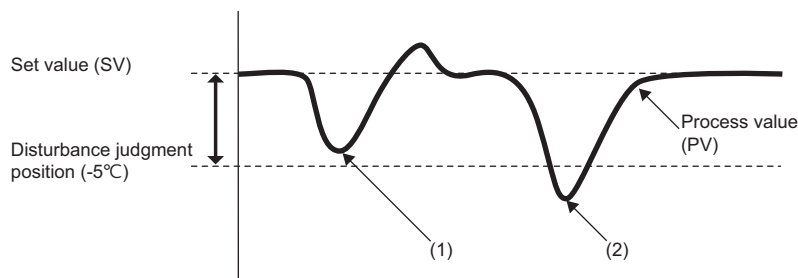

- (1) The disturbance suppression function does not operate because the deviation is less than -5°C .
 (2) The disturbance suppression function operates because the deviation is -5°C or larger.

■ Buffer memory address

The following shows the buffer memory address of this area.

Buffer memory area name	CH1	CH2	CH3	CH4
CH□ Disturbance judgment position	557	757	957	1157
CH□ Disturbance judgment position (in the Q compatible mode)	1044	1060	1076	1092

■Setting range

The setting range is -(Full scale of the input range) to the full scale of the input range. (°C(°F))

The setting range depends on the setting of 'CH1 Input range' (Un\G51).

The disturbance suppression function does not operate when 0 is set.

■Setting unit

The value to be set differs depending on the value stored in 'CH1 Decimal point position' (Un\G400).

- No decimal point (0): Set a value in increments of 1°C (°F or digit).
- First decimal place (1): Set a value (the value multiplied by 10) in increments of 0.1°C (°F).

Point

-
- When 'Automatic setting at input range change' (Un\G302) has been set to Enable (1), changing the value in 'CH1 Input range' (Un\G501) sets 0 in this area.
 - When 'Automatic setting at input range change' (Un\G302) has been set to Disable (0), the value in 'CH1 Disturbance judgment position' (Un\G557) may be out of the setting range.
-

■Default value

The default value is 0.

CH1 Set value return adjustment

Set a return action to be taken when the temperature process value (PV) returns to the set value (SV) from the temperature fall caused by disturbance. The overshoots amount and recovery time can be adjusted.

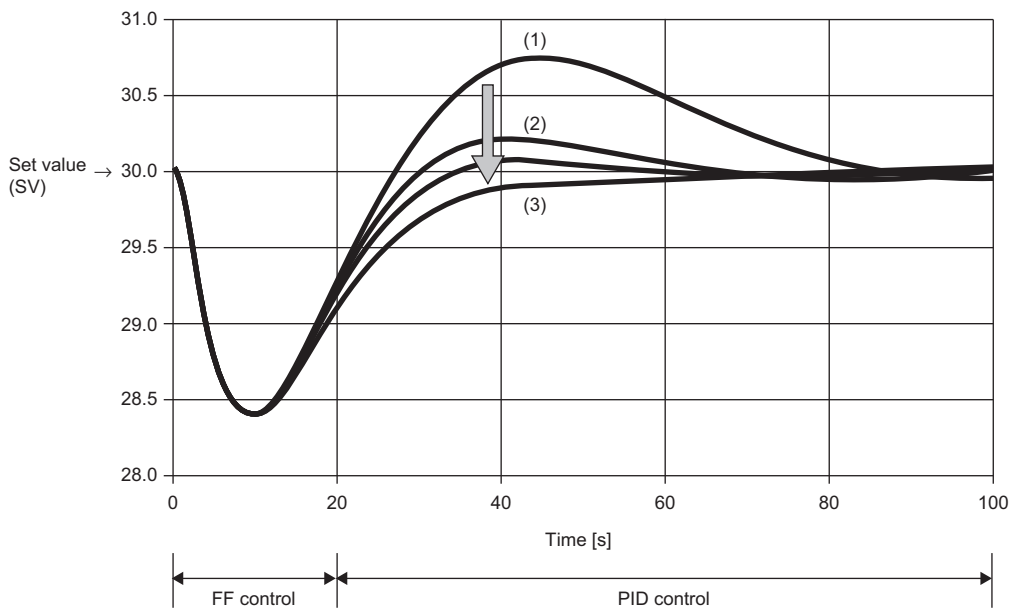

- (1) PID control (no return adjustment)
- (2) Return adjustment value: Small
- (3) Return adjustment value: Large

■Buffer memory address

The following shows the buffer memory address of this area.

Buffer memory area name	CH1	CH2	CH3	CH4
CH□ Set value return adjustment	558	758	958	1158
CH□ Set value return adjustment (in the Q compatible mode)	1045	1061	1077	1093

■Setting range

The setting range is 0 to 10.

When 0 is set, the return adjustment to the set value is not executed.

■Default value

The default value is 0.

CH1 Feed forward control forced starting signal

This signal forcibly starts the feed forward.

■Buffer memory address

The following shows the buffer memory address of this area.

Buffer memory area name	CH1	CH2	CH3	CH4
CH□ Feed forward control forced starting signal	559	759	959	1159
CH□ Feed forward control forced starting signal (in the Q compatible mode)	1046	1062	1078	1094

■Setting range

- 0: Feed forward control forced start stop
- 1: Feed forward control forced start

■Default value

The default value is Feed forward control forced start stop (0).

CH1 Feed forward value

Set the value to be added to the manipulated value (MV) in the feed forward control.

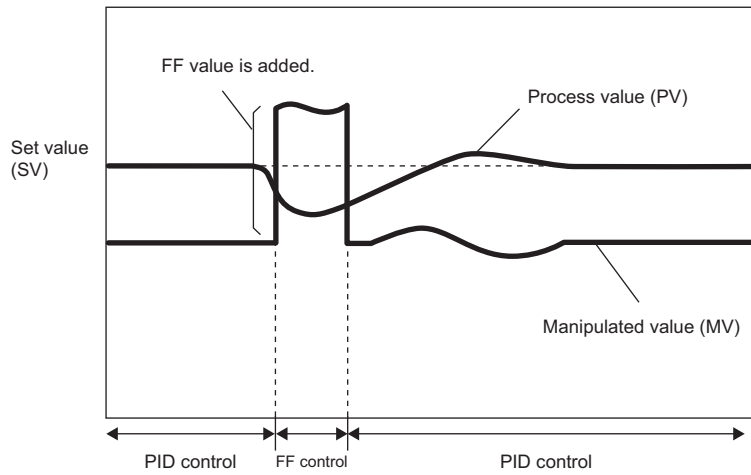

■ Buffer memory address

The following shows the buffer memory address of this area.

Buffer memory area name	CH1	CH2	CH3	CH4
CH□ Feed forward value	560	760	960	1160
CH□ Feed forward value (in the Q compatible mode)	1047	1063	1079	1095

■ Setting range

The setting range is -1000 to 1000 (-100.0 to 100.0%).

■ Default value

The default value is 0 (0.0%).

CH1 Feed forward value tuning selection

Set whether to execute the tuning of the feed forward value automatically or manually when the disturbance suppression function operates for the first time or when the set value (SV) or PID constants are changed.

When the control response after the tuning result is not satisfactory, turn off and on Feed forward value tuning selection to generate a disturbance and execute the tuning again.

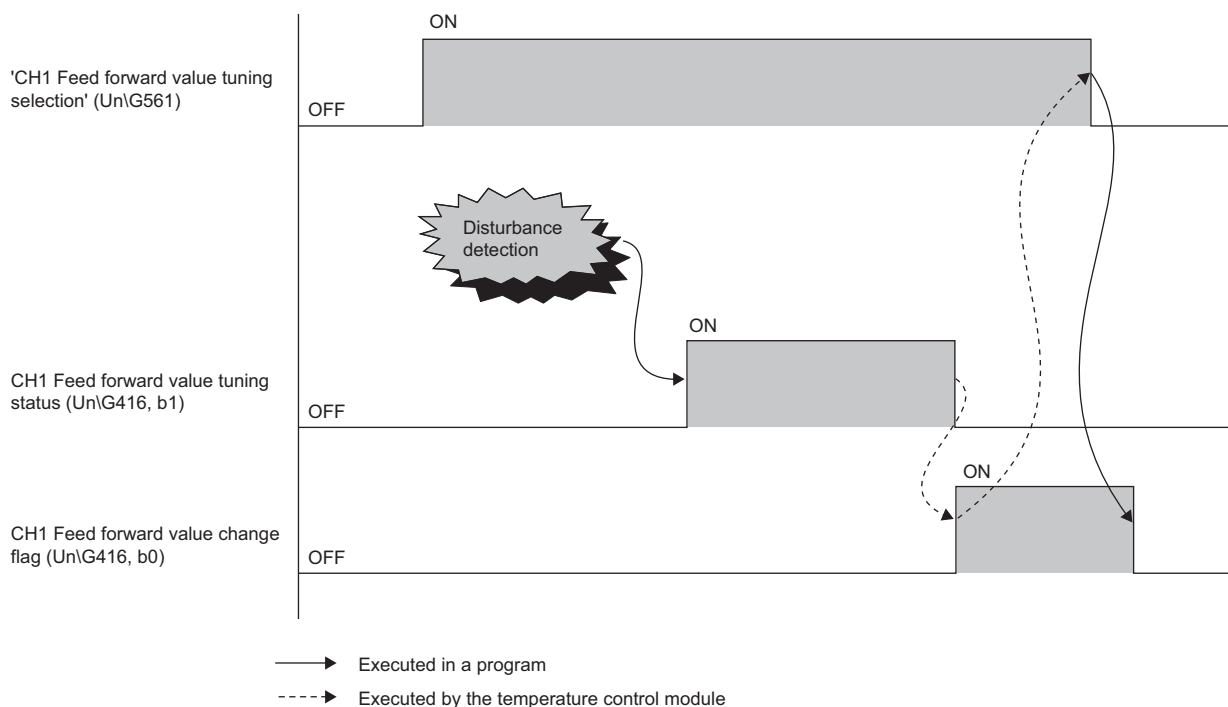

Set 'CH1 Disturbance judgment position' (UnG557) and set 'CH1 Feed forward value tuning selection' (UnG561) to Automatic setting (1).

When the temperature process value (PV) is out of the disturbance judgment position, the function automatically sets the feed forward value.

After the automatic setting, CH1 Feed forward value change flag (UnG416, b0) turns on.

■ Buffer memory address

The following shows the buffer memory address of this area.

Buffer memory area name	CH1	CH2	CH3	CH4
CH□ Feed forward value tuning selection	561	761	961	1161
CH□ Feed forward value tuning selection (in the Q compatible mode)	1048	1064	1080	1096

■ Setting range

- 0: No automatic setting
- 1: Automatic setting



When No automatic setting (0) is set, manually set 'CH1 Feed forward value' (UnG560).

■ Default value

The default value is No automatic setting (0).

CH1 Overshoot suppression level setting

Overshoots at the startup and the set value (SV) change are suppressed.

■Buffer memory address

The following shows the buffer memory address of this area.

Buffer memory area name	CH1	CH2	CH3	CH4
CH□ Overshoot suppression level setting	562	762	962	1162
CH□ Overshoot suppression level setting (in the Q compatible mode)	1050	1066	1082	1098

■Setting range

The setting range is 0 to 4.

When 0 is set, overshoots are not suppressed.

■Default value

The default value is 0.

CH1 Primary delay digital filter setting

The temperature process value (PV) are smoothed and sudden changes are absorbed by using the primary delay digital filter.

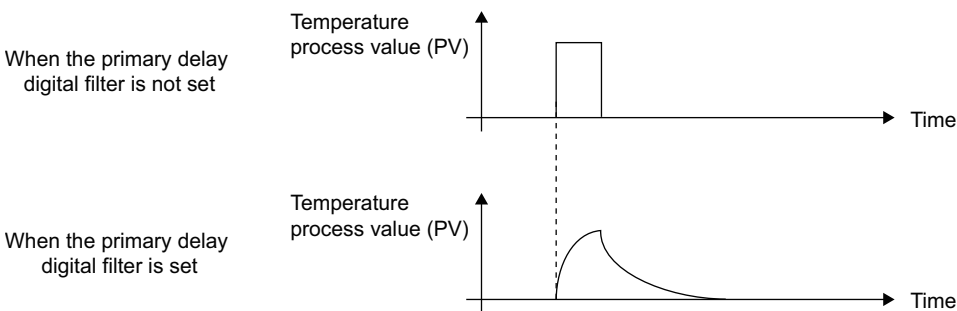

The time for the temperature process value (PV) to change by 63.3% can be set by the primary delay digital filter setting (filter setting time).

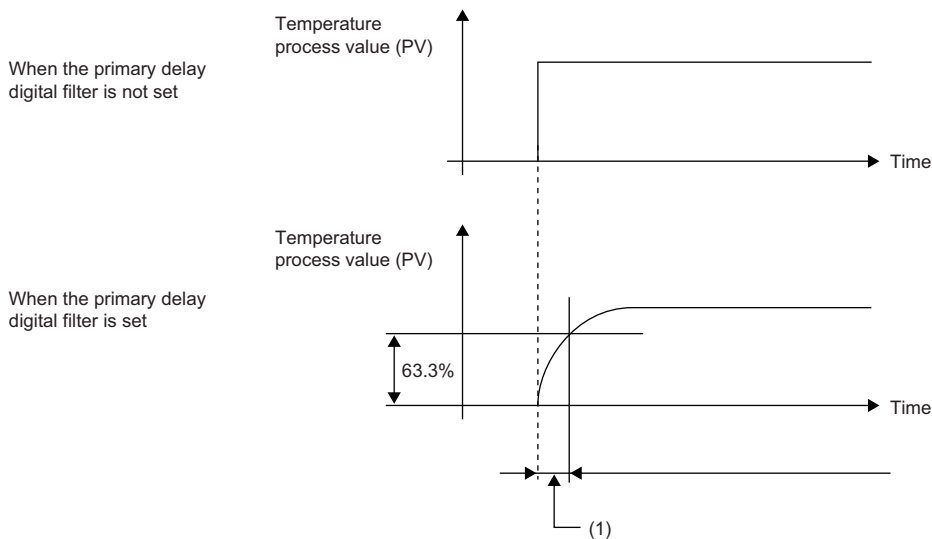

(1) 'CH1 Primary delay digital filter setting' (Un\G563)

■ Buffer memory address

The following shows the buffer memory address of this area.

Buffer memory area name	CH1	CH2	CH3	CH4
CH□ Primary delay digital filter setting	563	763	963	1163
CH□ Primary delay digital filter setting (in the Q compatible mode)	48	80	112	144

■ Setting range

The setting range is 0 or 1 to 100 (1 to 100s). When 0 is set, the primary delay digital filter processing is not executed.

■ Default value

The default value is 0. (The primary delay digital filter processing is disabled.)

CH1 Sensor correction function selection

Select a sensor correction method.

For details on the sensor correction function, refer to the following.

☞ Page 56 Sensor Correction Function

■ Buffer memory address

The following shows the buffer memory address of this area.

Buffer memory area name	CH1	CH2	CH3	CH4
CH□ Sensor correction function selection	564	764	964	1164

■ Setting range

- 0: Normal sensor correction (one-point correction)
- 1: Sensor two-point correction

■ Enabling the settings

Turn on and off 'Setting change command' (YB) in the setting mode ('Setting/operation mode status' (X1): Off) to enable the settings.

■ Default value

The default value is Normal sensor correction (one-point correction) (0H).

Sensor correction function selection [Q compatible mode]

Select a sensor correction method for each channel in the Q compatible mode.

For details on the sensor correction function, refer to the following.

☞ Page 56 Sensor Correction Function

b15 to b12	b11 to b8	b7 to b4	b3 to b0
CH4	CH3	CH2	CH1

■ Buffer memory address

The following shows the buffer memory address of this area.

Buffer memory area name	CH1	CH2	CH3	CH4
Sensor correction function selection (in the Q compatible mode)	785			

■ Setting range

- 0: Normal sensor correction (one-point correction)
- 1: Sensor two-point correction

■ Enabling the settings

Turn on and off 'Setting change command' (YB) in the setting mode ('Setting/operation mode status' (X1): Off) to enable the settings.

■ Default value

The default value is Normal sensor correction (one-point correction) (0H).

CH1 Sensor correction value setting

Set the correction value used when there is an error between a measured temperature and the actual temperature. For details on the sensor correction function, refer to the following.

 Page 56 Sensor Correction Function

■ Buffer memory address

The following shows the buffer memory address of this area.

Buffer memory area name	CH1	CH2	CH3	CH4
CH□ Sensor correction value setting	565	765	965	1165
CH□ Sensor correction value setting (in the Q compatible mode)	45	77	109	141

■ Setting range

- In the R mode

(-(Full scale of the input range)) to Full scale of the input range (°C (°F)).

The setting range depends on the setting of 'CH1 Input range' (Un\G501).

- In the Q compatible mode

Set a value within the range of -5000 to 5000 (-50.00 to 50.00%) to the full scale of the set input range.

■ Setting unit (in the R mode)

The value to be set differs depending on the value stored in 'CH1 Decimal point position' (Un\G400).

- No decimal point (0): Set a value in increments of 1°C (°F or digit).
- First decimal place (1): Set a value (the value multiplied by 10) in increments of 0.1°C (°F).

■ Enabling the settings

This setting is enabled when 'CH1 Sensor correction function selection' (Un\G564) has been set to Normal sensor correction (one-point correction) (0).

■ Default value

The default value is 0.

CH1 Sensor two-point correction offset latch request

This request is for storing the temperature process value (PV) as the sensor two-point correction offset value in the following buffer memory area.

- 'CH1 Sensor two-point correction offset value (measured value)' (Un\G568)

For details on the sensor two-point correction function, refer to the following.

 Page 56 Sensor Correction Function

■ Buffer memory address

The following shows the buffer memory address of this area.

Buffer memory area name	CH1	CH2	CH3	CH4
CH□ Sensor two-point correction offset latch request	566	766	966	1166
CH□ Sensor two-point correction offset latch request (in the Q compatible mode)	548	580	612	644

■ Setting range

- 0: No request
- 1: Latch request

■ Default value

The default value is No request (0).

■ Enabling the stored value

In the setting mode ('Setting/operation mode status' (X1): Off)



The conversion is prohibited in the operation mode ('Setting/operation mode status' (X1): On).

CH1 Sensor two-point correction gain latch request

This request is for storing the temperature process value (PV) as the sensor two-point correction gain value in the following buffer memory area.

- 'CH1 Sensor two-point correction gain value (measured value)' (Un\G570)

For details on the sensor two-point correction function, refer to the following.

 Page 56 Sensor Correction Function

■Buffer memory address

The following shows the buffer memory address of this area.

Buffer memory area name	CH1	CH2	CH3	CH4
CH□ Sensor two-point correction gain latch request	567	767	967	1167
CH□ Sensor two-point correction gain latch request (in the Q compatible mode)	550	582	614	646

■Setting range

- 0: No request
- 1: Latch request

■Default value

The default value is No request (0).

■Enabling the stored value

In the setting mode ('Setting/operation mode status' (X1): Off)



The conversion is prohibited in the operation mode ('Setting/operation mode status' (X1): On).

CH1 Sensor two-point correction offset value (measured value)

The measured value of the temperature corresponding to the sensor two-point correction offset value is stored in this buffer memory area.

The value to be stored differs depending on the value stored in 'CH1 Decimal point position' (Un\G400).

- When 'CH1 Decimal point position' (Un\G400) is No decimal point (0): A detected temperature value is stored as it is.
- When 'CH1 Decimal point position' (Un\G400) is First decimal place (1): A detected temperature value is stored after being multiplied by 10.

For details on the sensor two-point correction function, refer to the following.

 Page 56 Sensor Correction Function

■Buffer memory address

The following shows the buffer memory address of this area.

Buffer memory area name	CH1	CH2	CH3	CH4
CH□ Sensor two-point correction offset value (measured value)	568	768	968	1168
CH□ Sensor two-point correction offset value (measured value) (in the Q compatible mode)	544	576	608	640

■Enabling the stored value

Turn on and off 'Setting change command' (YB) in the setting mode ('Setting/operation mode status' (X1): Off) to enable the settings.

CH1 Sensor two-point correction offset value (corrected value)

The correction value of the temperature corresponding to the sensor two-point correction offset value is stored in this buffer memory area. For details on the sensor two-point correction function, refer to the following.

☞ Page 56 Sensor Correction Function

■Buffer memory address

The following shows the buffer memory address of this area.

Buffer memory area name	CH1	CH2	CH3	CH4
CH□ Sensor two-point correction offset value (corrected value)	569	769	969	1169
CH□ Sensor two-point correction offset value (corrected value) (in the Q compatible mode)	545	577	609	641

■Setting range

The temperature measuring range set in 'CH1 Input range' (Un\G501) (☞ Page 247 CH1 Input range)

■Setting unit

The value to be set differs depending on the value stored in 'CH1 Decimal point position' (Un\G400). (☞ Page 223 CH1 Decimal point position)

- No decimal point (0): Set a value in increments of 1°C (°F or digit).
- First decimal place (1): Set a value (the value multiplied by 10) in increments of 0.1°C (°F).

■Enabling the settings

Turn on and off 'Setting change command' (YB) in the setting mode ('Setting/operation mode status' (X1): Off) to enable the settings.

■Default value

The default value is 0.

CH1 Sensor two-point correction gain value (measured value)

The measured value of the temperature corresponding to the sensor two-point correction gain value is stored in this buffer memory area.

The value to be stored differs depending on the value stored in 'CH1 Decimal point position' (Un\G400). (☞ Page 223 CH1 Decimal point position)

- When 'CH1 Decimal point position' (Un\G400) is No decimal point (0): A detected temperature value is stored as it is.
- When 'CH1 Decimal point position' (Un\G400) is First decimal place (1): A detected temperature value is stored after being multiplied by 10.

For details on the sensor two-point correction function, refer to the following.

☞ Page 56 Sensor Correction Function

■Buffer memory address

The following shows the buffer memory address of this area.

Buffer memory area name	CH1	CH2	CH3	CH4
CH□ Sensor two-point correction gain value (measured value)	570	770	970	1170
CH□ Sensor two-point correction gain value (measured value) (in the Q compatible mode)	546	578	610	642

■Enabling the stored value

Turn on and off 'Setting change command' (YB) in the setting mode ('Setting/operation mode status' (X1): Off) to enable the settings.

CH1 Sensor two-point correction gain value (corrected value)

The correction value of the temperature corresponding to the sensor two-point correction gain value is stored in this buffer memory area. For details on the sensor two-point correction function, refer to the following.

 Page 56 Sensor Correction Function

■Buffer memory address

The following shows the buffer memory address of this area.

Buffer memory area name	CH1	CH2	CH3	CH4
CH□ Sensor two-point correction gain value (corrected value)	571	771	971	1171
CH□ Sensor two-point correction gain value (corrected value) (in the Q compatible mode)	547	579	611	643

■Setting range

The temperature measuring range set in 'CH1 Input range' (Un\G501) ( Page 247 CH1 Input range)

■Setting unit

The value to be set differs depending on the value stored in 'CH1 Decimal point position' (Un\G400). ( Page 223 CH1 Decimal point position)

- No decimal point (0): Set a value in increments of 1°C (°F or digit).
- First decimal place (1): Set a value (the value multiplied by 10) in increments of 0.1°C (°F).

■Enabling the settings

Turn on and off 'Setting change command' (YB) in the setting mode ('Setting/operation mode status' (X1): Off) to enable the settings.

■Default value

The default value is 0.

CH1 Number of moving averaging setting

Set the number of moving averaging to be executed to temperature process values (PV).

For details on the moving average processing to temperature process values (PV), refer to the following.

 Page 65 Moving Average Processing

This setting is enabled only when 'Moving average processing setting' (Un\G305) has been set to Enable (0).

This setting is disabled when 'Moving average processing setting' (Un\G305) has been set to Disable (1).

For details on 'Moving average processing setting' (Un\G305), refer to the following.

 Page 220 Moving average processing setting

Point

In the Q compatible mode, set the number of moving averaging in 'Moving average processing setting' (in the Q compatible mode) (Un\G1024, b3).

■Buffer memory address

The following shows the buffer memory address of this area.

Buffer memory area name	CH1	CH2	CH3	CH4
CH□ Number of moving averaging setting	572	772	972	1172
CH□ Number of moving averaging setting (in the Q compatible mode)	698	699	700	701

■Setting range

2 to 10 (times)

■Default value

The default value is 2 (times).

Heater disconnection/output off-time current error detection delay count

Set the limit value for consecutive heater disconnection detections and output off-time current error detections so that the number of errors exceeding the limit value triggers an alert judgment.

For details on the heater disconnection detection function, refer to the following.

☞ Page 83 Heater Disconnection Detection Function

For details on the output off-time current error detection function, refer to the following.

☞ Page 87 Output Off-time Current Error Detection Function

■Buffer memory address

The following shows the buffer memory address of this area.

Buffer memory area name	CH1	CH2	CH3	CH4
Heater disconnection/output off-time current error detection delay count	2000			
Heater disconnection/output off-time current error detection delay count (in the Q compatible mode)	166			

■Settable modules

- R60TCRT2TT2BW
- R60TCRT4BW

■Setting range

The setting range is 3 to 255 (times).

■Default value

The default value is 3 (times).

Heater disconnection correction function selection

Set whether to use the heater disconnection correction function or not. For details on the heater disconnection correction function, refer to the following.

☞ Page 83 Heater Disconnection Detection Function

■Buffer memory address

The following shows the buffer memory address of this area.

Buffer memory area name	CH1	CH2	CH3	CH4
Heater disconnection correction function selection	2001			
Heater disconnection correction function selection (in the Q compatible mode)	170			

■Settable modules

- R60TCRT2TT2BW
- R60TCRT4BW

■Setting range

- 0: Heater disconnection correction function not used
- 1: Heater disconnection correction function used

■Default value

The default value is Heater disconnection correction function not used (0).

CT monitor method selection

Set the method for executing the heater current measurement.

■Buffer memory address

The following shows the buffer memory address of this area.

Buffer memory area name	CH1	CH2	CH3	CH4
CT monitor method selection	2002			
CT monitor method selection (in the Q compatible mode)	176			

■Settable modules

- R60TCTRT2TT2BW
- R60TCRT4BW

■Setting range

- 0: ON/OFF current
- 1: ON current

When ON/OFF current (0) is set, the present current value of the current sensor (CT) is measured.

When ON current (1) is set, the current value of the heater being off is fixed as the current value of the heater previously being on.

■Default value

The default value is ON/OFF current (0).

CH1 Heater disconnection alert setting

Set the set value used for heater disconnection detections and output off-time current error detections in percentage (%) of the reference heater current value.

For details on the heater disconnection detection function, refer to the following.

 Page 83 Heater Disconnection Detection Function

For details on the output off-time current error detection function, refer to the following.

 Page 87 Output Off-time Current Error Detection Function

■Buffer memory address

The following shows the buffer memory address of this area.

Buffer memory area name	CH1	CH2	CH3	CH4
CH□ Heater disconnection alert setting	2004	2007	2010	2013
CH□ Heater disconnection alert setting (in the Q compatible mode)	58	90	122	154

■Supported modules

- R60TCTRT2TT2BW
- R60TCRT4BW

■Setting range

The setting range is 0 to 100 (%).

Point

An out of setting range error (error code: 1950H) occurs when the current value to be used as a judgment value to detect heater disconnections (Reference heater current value × CH□ Heater disconnection alert setting (%)) is smaller than 0.1A or 0.01A. For details on the setting, refer to the following.

 Page 83 Setting method

Ex.

To generate a heater disconnection alert when 'CT1 Heater current process value' (Un\G2030) becomes 80 (8.0A) or lower while 'CT1 Reference heater current value' (Un\G2054) has been set to 100 (10.0A), set the following value.

- 'CH1 Heater disconnection alert setting' (Un\G2004): 80(%)

$$\text{Heater disconnection alert setting} = 100 - \frac{\text{Reference heater current value} - \text{Heater current process value}}{\text{Reference heater current value}} \times 100 = 100 - \frac{100 - 80}{100} \times 100 = 80(\%)$$

When 0 is set, heater disconnection detections and output off-time current error detections are not executed.

Default value

The default value is 0 (%).

CH1 Heater disconnection judgment mode

Set whether to execute the heater disconnection judgment in the normal mode or the high accuracy mode. For details on the heater disconnection detection function, refer to the following.

☞ Page 83 Heater Disconnection Detection Function

Buffer memory address

The following shows the buffer memory address of this area.

Buffer memory area name	CH1	CH2	CH3	CH4
CH□ Heater disconnection judgment mode	2005	2008	2011	2014
CH□ Heater disconnection judgment mode (in the Q compatible mode)	1051	1067	1083	1099

Setting range

- 0: Normal mode
- 1: High accuracy mode

Enabling the settings

Turn on and off 'Setting change command' (YB) in the setting mode ('Setting/operation mode status' (X1): Off) to enable the settings.

Default value

The default value is Normal mode (0).

CT1 Heater current process value

A heater current value detected by the R60CTTRT2TT2BW or R60TCRT4BW is stored in this buffer memory area. The value to be stored differs depending on the setting of 'CT1 CT selection' (Un\G2046) or 'CT1 CT selection' (in the Q compatible mode) (Un\G272). (☞ Page 303 CT1 CT selection, Page 304 CT1 CT selection [Q compatible mode])

- In the R mode

'CT1 CT selection' (Un\G2046)	Range of values to be stored
CTL-12L-8 (0.0 to 100.0A) (0)	0 to 1050 (0.0 to 105.0A)
CTL-6-P-H/CTL-6-S-H (0.00 to 20.00A) (1)	0 to 2100 (0.00 to 21.00A)
CTL-12-S36-10/CTL-12-S56-10 (0.0 to 100.0A) (2)	0 to 1050 (0.0 to 105.0A)
CT ratio setting (0.0 to 100.0A) (3)	0 to 1050 (0.0 to 105.0A)

- In the Q compatible mode

'CT1 CT selection' (in the Q compatible mode) (Un\G272)	Range of values to be stored
CTL-12-S36-8 (0.0 to 100.0A) (0)	0 to 1050 (0.0 to 105.0A)
CTL-6-P(-H) (0.00 to 20.00A) (1)	0 to 2100 (0.00 to 21.00A)
CT ratio setting (0.0 to 100.0A) (2)	0 to 1050 (0.0 to 105.0A)

■Buffer memory address

The following shows the buffer memory address of this area.

CT input terminal	Buffer memory address	
	In the R mode	In the Q compatible mode
CT1	2030	256
CT2	2031	257
CT3	2032	258
CT4	2033	259
CT5	2034	260
CT6	2035	261
CT7	2036	262
CT8	2037	263

■Supported modules

- R60CTTRT2TT2BW
- R60TCRT4BW

Point

To start the measurement of the heater current, the following buffer memory areas need to be set.

- 'CT1 CT input channel assignment setting' (Un\G2038) (☞ Page 303 CT1 CT input channel assignment setting)
- 'CT1 Reference heater current value' (Un\G2054) (☞ Page 306 CT1 Reference heater current value)

When both buffer memory areas have been set to 0, the heater current cannot be measured. When either of them has not been set, the heater current cannot be measured properly.

CT1 CT input channel assignment setting

Set the assignment of each current sensor (CT) input to the channels.

■Correspondence between each CT input terminal and buffer memory address

CT input terminal	Buffer memory address	
	In the R mode	In the Q compatible mode
CT1	2038	264
CT2	2039	265
CT3	2040	266
CT4	2041	267
CT5	2042	268
CT6	2043	269
CT7	2044	270
CT8	2045	271

■Setting range

- 0: Not used
- 1: CH1
- 2: CH2
- 3: CH3
- 4: CH4

■Default value

The default value is Not used (0).

Point

- When using a three-phase heater, assign the same channel to two current sensor (CT) inputs. ( MELSEC iQ-R Temperature Control Module User's Manual (Startup))
- In the heating-cooling control or position-proportional control, CH3 and CH4 cannot be assigned to this setting.
- In the mix control, CH2 cannot be assigned to this setting.

CT1 CT selection

Select the current sensor (CT) to be connected to CT1 in the R mode.

■Setting range

- 0: CTL-12L-8 (0.0 to 100.0A)
- 1: CTL-6-P-H/CTL-6-S-H (0.00 to 20.00A)
- 2: CTL-12-S36-10/CTL-12-S56-10 (0.0 to 100.0A)
- 3: CT ratio setting (0.0 to 100.0A)

A

■Correspondence between each CT input terminal and buffer memory address

CT input terminal	Buffer memory address
CT1	2046
CT2	2047
CT3	2048
CT4	2049
CT5	2050
CT6	2051
CT7	2052
CT8	2053

■Setting current sensors (CT) and buffer memory areas

Set the following buffer memory areas as follows according to the specifications of the current sensor (CT) to be used.

Current sensor (CT) to be used	'CT1 CT selection' (Un\G2046)	'CT1 CT ratio setting' (Un\G2062)	Remarks
Products of U.R.D.Co., LTD.	CTL-12L-8	CTL-12L-8 (0.0 to 100.0A) (0)	Setting not required
	CTL-6-P-H	CTL-6-P-H/CTL-6-S-H (0.00 to 20.00A) (1)	Setting not required
	CTL-6-S-H	CTL-6-P-H/CTL-6-S-H (0.00 to 20.00A) (1)	Setting not required
	CTL-12-S36-10	CTL-12-S36-10/CTL-12-S56-10 (0.0 to 100.0A) (2)	Setting not required
	CTL-12-S56-10	CTL-12-S36-10/CTL-12-S56-10 (0.0 to 100.0A) (2)	Setting not required
Other current sensors (CT)	CT ratio setting (0.0 to 100.0A) (3)	Set the number of second-winding (turns) depending on the specifications of the current sensor (CT) used.	Current sensors (CT) whose number of second-winding (turns) is 600 to 9999 can be used.



- When using the CTL-12-S36-8 current sensor (CT), set CTL-12L-8 (0.0 to 100.0A) (0).
- When using the CTL-6-P current sensor (CT), set CTL-6-P-H/CTL-6-S-H (0.00 to 20.00A) (1).

■Enabling the settings

Turn on and off 'Setting change command' (YB) in the setting mode ('Setting/operation mode status' (X1): Off) to enable the settings.

■Occurrence of a write data error

When a value out of the setting value is set, a write data error (error code: 1950H) occurs. 'Error flag' (X2) turns on and the error code is stored in 'Latest error code' (Un\G0).

■Default value

The default value is CTL-12L-8 (0.0 to 100.0A) (0).

CT1 CT selection [Q compatible mode]

Select the current sensor (CT) to be connected to CT1 in the Q compatible mode.

■Setting range

- 0: CTL-12-S36-8 (0.0 to 100.0A)
- 1: CTL-6-P(-H) (0.00 to 20.00A)
- 2: CT ratio setting (0.0 to 100.0A)

■Correspondence between each CT input terminal and buffer memory address

CT input terminal	Buffer memory address
CT1	272
CT2	273
CT3	274
CT4	275
CT5	276
CT6	277
CT7	278
CT8	279

■Setting current sensors (CT) and buffer memory areas

When using a current sensor (CT) other than the CTL-12-S36-8 and CTL-6-P(-H), set the number of second-winding (turns) of the current sensor (CT) to be connected in 'CT1 CT ratio setting' (in the Q compatible mode) (Un\G288). Set the following buffer memory areas as follows according to the specifications of the current sensor (CT) to be used.

Current sensor (CT) to be used	'CT1 CT selection' (in the Q compatible mode) (Un\G272)	'CT1 CT ratio setting' (in the Q compatible mode) (Un\G288)	Remarks
Products of U.R.D.Co., LTD.	CTL-12-S36-8	CTL-12-S36-8 (0.0 to 100.0A) (0)	Setting not required
	CTL-6-P	CTL-6-P(-H) (0.00 to 20.00A) (1)	Setting not required
	CTL-6-P-H	CTL-6-P(-H) (0.00 to 20.00A) (1)	Setting not required
	CTL-12-S36-10	CT ratio setting (0.0 to 100.0A) (2)	Set 1000, which is the number of second-winding (turns).
	CTL-12-S56-10	CT ratio setting (0.0 to 100.0A) (2)	Set 1000, which is the number of second-winding (turns).
Other current sensors (CT)	CT ratio setting (0.0 to 100.0A) (2)	Set the number of second-winding (turns) depending on the specifications of the current sensor (CT) used.	Current sensors (CT) whose number of second-winding (turns) is 600 to 9999 can be used.

Point

- When using the CTL-12-L-8 current sensor (CT), set CTL-12-S36-8 (0.0 to 100.0A) (0).
- When using the CTL-6-S-H current sensor (CT), set CTL-6-P(-H) (0.00 to 20.00A) (1).

■Enabling the settings

Turn on and off 'Setting change command' (YB) in the setting mode ('Setting/operation mode status' (X1): Off) to enable the settings.

■Occurrence of a write data error

When a value out of the setting value is set, an out of setting range error (error code: 1950H) occurs. 'Error flag' (X2) turns on and the error code is stored in 'Latest error code' (in the Q compatible mode) (Un\G0).

■Default value

The default value is CTL-12-S36-8 (0.0 to 100.0A) (0).

Point

When CT ratio setting (0.0 to 100.0A) (2) has been selected, the setting of 'CT1 CT ratio setting' (in the Q compatible mode) (Un\G288) is enabled. In advance, set a value in 'CT1 CT ratio setting' (in the Q compatible mode) (Un\G288) corresponding to the sensor to be connected. After that, select CT ratio setting (0.0 to 100.0A) (2).

A

CT1 Reference heater current value

Set the reference value of 'CT1 Heater current process value' (Un\G2030) for when the heater is turned on. ( Page 302 CT1 Heater current process value)

■Correspondence between each CT input terminal and buffer memory address

CT input terminal	Buffer memory address	
	In the R mode	In the Q compatible mode
CT1	2054	280
CT2	2055	281
CT3	2056	282
CT4	2057	283
CT5	2058	284
CT6	2059	285
CT7	2060	286
CT8	2061	287

■Setting range

The setting range is within the heater current range of the current sensor set in 'CT1 CT selection' (Un\G2046).

'CT1 CT selection' (Un\G2046)	Setting range
<ul style="list-style-type: none">• CTL-12-S36-8 (0.0 to 100.0A) (0)• CTL-12-S36-10/CTL-12-S56-10 (2)• CT ratio setting (0.0 to 100.0A) (3)	0 to 1000 (0.0 to 100.0A)
CTL-6-P(-H) (0.00 to 20.00A) (1)	0 to 2000 (0.00 to 20.00A)

■Default value

The default value is 0 (0.0A).

CT1 CT ratio setting

Set the number of second-winding (turns) of the current sensor (CT) to be connected. This setting is enabled only when 'CT1 CT selection' (Un\G2046) has been set to CT ratio setting (0.0 to 100.0A) (3). (In the Q compatible mode, this setting is enabled only when 'CT1 CT selection' (Un\G2046) has been set to CT ratio setting (0.0 to 100.0A) (2).) ( Page 303 CT1 CT selection, Page 304 CT1 CT selection [Q compatible mode])

■Correspondence between each CT input terminal and buffer memory address

CT input terminal	Buffer memory address	
	In the R mode	In the Q compatible mode
CT1	2062	288
CT2	2063	289
CT3	2064	290
CT4	2065	291
CT5	2066	292
CT6	2067	293
CT7	2068	294
CT8	2069	295

■Setting range

The setting range is 600 to 9999.

■Default value

The default value is 800.

Inter-module peak current suppression function state monitor

The status of the inter-module peak current suppression function can be checked.

The status of the inter-module peak current suppression function of the channel corresponding to each bit is stored.

- 0: Stop
- 1: In execution

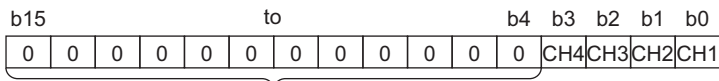

Bit data from b15 to b4 are fixed to 0.

■ Buffer memory address

The following shows the buffer memory address of this area.

Buffer memory area name	CH1	CH2	CH3	CH4
Inter-module peak current suppression function state monitor	2100			
Inter-module peak current suppression function state monitor (in the Q compatible mode)	1280			

Inter-module peak current suppression function enable/disable monitor

Whether the inter-module peak current suppression function is enabled or disabled can be checked.

- 0: Disable
- 1: Enable

For details on the inter-module peak current suppression function, refer to the following.

Page 108 Inter-module peak current suppression function

■ Buffer memory address

The following shows the buffer memory address of this area.

Buffer memory area name	CH1	CH2	CH3	CH4
Inter-module peak current suppression function enable/disable monitor	2101			
Inter-module peak current suppression function enable/disable monitor (in the Q compatible mode)	1281			

A

Inter-module peak current suppression function master/slave selection monitor

Whether the inter-module peak current suppression function has been set to Master or Slave can be checked.

- 0: Slave
- 1: Master

For details on the inter-module peak current suppression function, refer to the following.

Page 108 Inter-module peak current suppression function

■ Buffer memory address

The following shows the buffer memory address of this area.

Buffer memory area name	CH1	CH2	CH3	CH4
Inter-module peak current suppression function master/slave selection monitor	2102			
Inter-module peak current suppression function master/slave selection monitor (in the Q compatible mode)	1282			

Number of slave modules with inter-module peak current suppression function enabled

The number of slave modules to which the inter-module peak current suppression function has been enabled can be checked. Check it with the temperature control module where 'Inter-module peak current suppression function master/slave selection monitor' (Un\G2102) has been set to Master (1).

■Buffer memory address

The following shows the buffer memory address of this area.

Buffer memory area name	CH1	CH2	CH3	CH4
Number of slave modules with inter-module peak current suppression function enabled	2103			
Number of slave modules with inter-module peak current suppression function enabled (in the Q compatible mode)	1283			

Start I/O of slave module with inter-module peak current suppression function enabled

The start I/O number of the slave modules to which the inter-module peak current suppression function has been enabled can be checked.

Check it with the temperature control module where 'Inter-module peak current suppression function master/slave selection monitor' (Un\G2102) has been set to Master (1).

■Buffer memory address

The following shows the buffer memory address of this area.

Buffer memory area name	CH1	CH2	CH3	CH4
Start I/O of slave module with inter-module peak current suppression function enabled	2104 to 2166			
Start I/O of slave module with inter-module peak current suppression function enabled (in the Q compatible mode)	1284 to 1346			

Inter-module simultaneous temperature rise function state monitor

The status of the inter-module simultaneous temperature rise function can be checked.

The status of the inter-module simultaneous temperature rise function of the channel corresponding to each bit is stored.

- 0: Stop
- 1: In execution

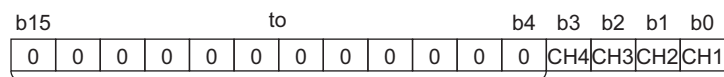

Bit data from b15 to b4 are fixed to 0.

■Buffer memory address

The following shows the buffer memory address of this area.

Buffer memory area name	CH1	CH2	CH3	CH4
Inter-module simultaneous temperature rise function state monitor	2170			
Inter-module simultaneous temperature rise function state monitor (in the Q compatible mode)	1350			

Inter-module simultaneous temperature rise function enable/disable monitor

Whether the inter-module simultaneous temperature rise function is enabled or disabled can be checked.

- 0: Disable
- 1: Enable

For details on the inter-module simultaneous temperature rise function, refer to the following.

 Page 110 Inter-module simultaneous temperature rise function

■Buffer memory address

The following shows the buffer memory address of this area.

Buffer memory area name	CH1	CH2	CH3	CH4
Inter-module simultaneous temperature rise function enable/disable monitor	2171			
Inter-module simultaneous temperature rise function enable/disable monitor (in the Q compatible mode)	1351			

Inter-module simultaneous temperature rise function master/slave selection monitor

Whether the inter-module simultaneous temperature rise function has been set to Master or Slave can be checked.

- 0: Slave
- 1: Master

For details on the inter-module simultaneous temperature rise function, refer to the following.

 Page 110 Inter-module simultaneous temperature rise function

■Buffer memory address

The following shows the buffer memory address of this area.

Buffer memory area name	CH1	CH2	CH3	CH4
Inter-module simultaneous temperature rise function master/slave selection monitor	2172			
Inter-module simultaneous temperature rise function master/slave selection monitor (in the Q compatible mode)	1352			

No. of slave modules with inter-module simultaneous temperature rise func. enabled

The number of slave modules to which the inter-module simultaneous temperature rise function has been enabled can be checked.

Check it with the temperature control module where 'Inter-module simultaneous temperature rise function master/slave selection monitor' (Un\G2172) has been set to Master (1).

■Buffer memory address

The following shows the buffer memory address of this area.

Buffer memory area name	CH1	CH2	CH3	CH4
Number of slave modules with inter-module simultaneous temperature rise function enabled	2173			
Number of slave modules with inter-module simultaneous temperature rise function enabled (in the Q compatible mode)	1353			

Start I/O of slave module with inter-module simultaneous temp. rise func. enabled

The start I/O number of the slave modules to which the inter-module simultaneous temperature rise function has been enabled can be checked.

Check it with the temperature control module where 'Inter-module simultaneous temperature rise function master/slave selection monitor' (Un\G2172) has been set to Master (1).

■Buffer memory address

The following shows the buffer memory address of this area.

Buffer memory area name	CH1	CH2	CH3	CH4
Start I/O of slave module with inter-module simultaneous temperature rise function enabled	2174 to 2236			
Start I/O of slave module with inter-module simultaneous temperature rise function enabled (in the Q compatible mode)	1354 to 1416			

Error history

Up to 16 errors that occurred in the module are recorded.

	b15	to	b8 b7	to	b0
Un\G3600	Error code				
Un\G3601	First two digits of the year		Last two digits of the year		
Un\G3602	Month		Day		
Un\G3603	Hour		Minute		
Un\G3604	Second		Day of the week		
Un\G3605	Millisecond (higher-order digits)		Millisecond (lower-order digits)		
Un\G3606	System area				
⋮					
Un\G3609					

Item	Stored contents	Storage example ^{*1}
First two digits of the year/last two digits of the year	Stored in BCD code.	2014H
Month/day		630H
Hour/minute		1234H
Second		56H
Day of the week	One of the following values is stored in BCD code. Sunday: 0, Monday: 1, Tuesday: 2, Wednesday: 3, Thursday: 4, Friday: 5, and Saturday: 6	1H
Millisecond (upper)	Stored in BCD code.	7H
Millisecond (lower)		89H

*1 Value stored when an error occurs at 12:34:56.789 on Monday, June 30, 2014

■Buffer memory address

The following shows the buffer memory address of this area.

Buffer memory area name	No. 1 to No. 16
Error history	3600 to 3759
Error history (in the Q compatible mode)	2000 to 2159

Alarm history

Up to 16 alarms that occurred in the module are recorded.

	b15	to	b8	b7	to	b0
Un\G1810	Error code					
Un\G1811	First two digits of the year			Last two digits of the year		
Un\G1812	Month			Day		
Un\G1813	Hour			Minute		
Un\G1814	Second			Day of the week		
Un\G1815	System area					
to						
Un\G1819						

Item	Stored contents	Storage example ^{*1}
First two digits of the year/last two digits of the year	Stored in BCD code.	2014H
Month/day		630H
Hour/minute		1234H
Second		56H
Day of the week	One of the following values is stored in BCD code. Sunday: 0, Monday: 1, Tuesday: 2, Wednesday: 3, Thursday: 4, Friday: 5, and Saturday: 6	1H
Millisecond (upper)	Stored in BCD code.	7H
Millisecond (lower)		89H

*1 Value stored when an alarm occurs at 12:34:56.789 on Monday, June 30, 2014

■ Buffer memory address

The following shows the buffer memory address of this area.

Buffer memory area name	No. 1 to No. 16
Alarm history	3760 to 3919
Alarm history (in the Q compatible mode)	2160 to 2319

A

Function extension bit monitor [Q compatible mode]

In the Q compatible mode, the following contents set in 'Sampling cycle and function extension setting' (in the Q compatible mode) (Un\G1024) are stored.

- Automatic setting at input range change
- Setting variation rate limiter setting
- Control output cycle unit selection setting
- Moving average processing setting

The following figure and table show how the settings are stored.

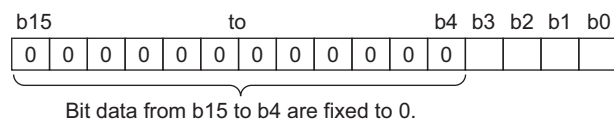

Bit	Flag name (Function extension bit monitor)	Description
b0	Automatic setting at input range change	When the input range is changed, the related buffer memory data is automatically changed to prevent the values in those buffer memory areas from being out of the setting range. • 0: Disable • 1: Enable
b1	Setting variation rate limiter setting	Select whether the setting variation rate limiter to be set in a batch or individually. • 0: Set in a batch at temperature rise/temperature drop • 1: Individually set at temperature rise/temperature drop
b2	Control output cycle unit selection setting	Select 0.1s or 1s as a unit for the cycle of turning on/off the transistor output. In the position-proportional control, 1s cycle (0) is selected. • 0: 1s cycle • 1: 0.1s cycle
b3	Moving average processing setting	Select whether the moving average processing setting is used. • 0: Enable • 1: Disable
b4 to b15	— (Fixed to 0)	— (Not used)

■ Buffer memory address

The following shows the buffer memory address of this area.

Buffer memory area name	CH1	CH2	CH3	CH4
Function extension bit monitor (in the Q compatible mode)	787			

Sampling cycle and function extension setting [Q compatible mode]

In the Q compatible mode, configure the following settings.

- Automatic setting at input range change
- Setting variation rate limiter setting
- Control output cycle unit selection setting
- Moving average processing setting
- Sampling cycle selection

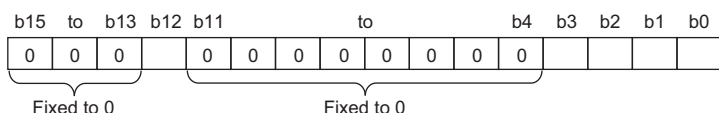

Bit	Flag name (Function extension bit monitor)	Description
b0	Automatic setting at input range change	When the input range is changed, the related buffer memory data is automatically changed to prevent the values in those buffer memory areas from being out of the setting range. • 0: Disable • 1: Enable
b1	Setting variation rate limiter setting	Select whether the setting variation rate limiter to be set in a batch or individually. • 0: Set in a batch at temperature rise/temperature drop • 1: Individually set at temperature rise/temperature drop
b2	Control output cycle unit selection setting	Select 0.1s or 1s as a unit for the cycle of turning on/off the transistor output. • 0: 1s cycle • 1: 0.1s cycle
b3	Moving average processing setting	Select whether the moving average processing setting is used. • 0: Enable • 1: Disable
b4 to b11	— (Fixed to 0)	— (Not used)
b12	Sampling cycle selection	Select 500ms/4CH or 250ms/4CH as the sampling cycle. • 0: 500ms/4CH • 1: 250ms/4CH
b13 to b15	— (Fixed to 0)	— (Not used)

When Automatic setting at input range change has been set to Enable (1), the following buffer memory areas are automatically set or initialized when the setting of 'CH1 Input range' (in the Q compatible mode) (Un\G32) is changed.

Buffer memory area name	Buffer memory address	Value after change
CH1 Set value (SV) setting (in the Q compatible mode)	34	0
CH1 Alert set value 1 to CH1 Alert set value 4 (in the Q compatible mode)	38 to 41	0
CH1 AT bias (in the Q compatible mode)	53	0
CH1 Upper limit setting limiter (in the Q compatible mode)	55	Upper limit value of the input range
CH1 Lower limit setting limiter (in the Q compatible mode)	56	Lower limit value of the input range
CH1 Loop disconnection detection dead band (in the Q compatible mode)	60	0
CH1 Sensor two-point correction offset value (measured value) (in the Q compatible mode)	544	0
CH1 Sensor two-point correction offset value (corrected value) (in the Q compatible mode)	545	0
CH1 Sensor two-point correction gain value (measured value) (in the Q compatible mode)	546	0
CH1 Sensor two-point correction gain value (corrected value) (in the Q compatible mode)	547	0
CH1 Simultaneous temperature rise gradient data (in the Q compatible mode)	731	0
CH1 Simultaneous temperature rise dead time (in the Q compatible mode)	732	0
CH1 Disturbance judgment position (in the Q compatible mode)	1044	0

Point 

- When the control output cycle unit has been changed, the control output cycle setting, heating control output cycle setting, and cooling control output cycle setting are overwritten with their default values. A set value discrepancy error (control output cycle unit selection setting) (error code: 1920H) occurs right after the control output cycle unit selection setting change. To clear the error, turn off and on 'Setting value backup command' (Y8) and register the parameter after the change in the non-volatile memory.
- A set value discrepancy error (sampling cycle) (error code: 1930H) occurs right after the sampling cycle change. To clear the error, turn off and on 'Setting value backup command' (Y8) and register the parameter after the change in the non-volatile memory.

■ Buffer memory address

The following shows the buffer memory address of this area.

Buffer memory area name	CH1	CH2	CH3	CH4
Sampling cycle and function extension setting (in the Q compatible mode)	1024			

Appendix 4 PID

This section describes PID.

PID control

This section describes the PID control of the temperature control module.

PID control system

The following figure shows a system for executing the PID control.

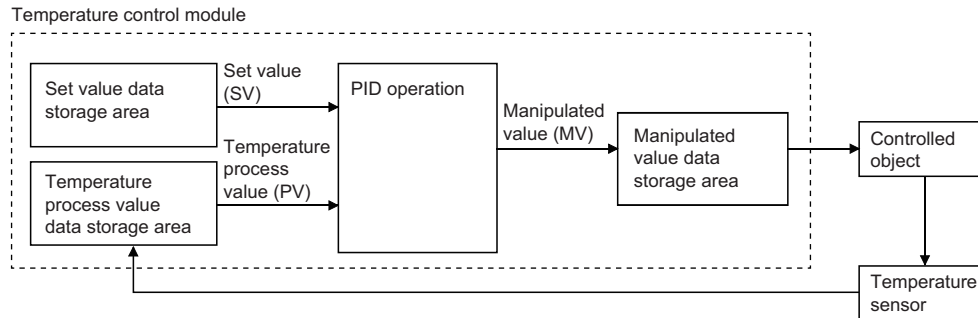

PID control procedure

The PID control is executed in the following procedure.

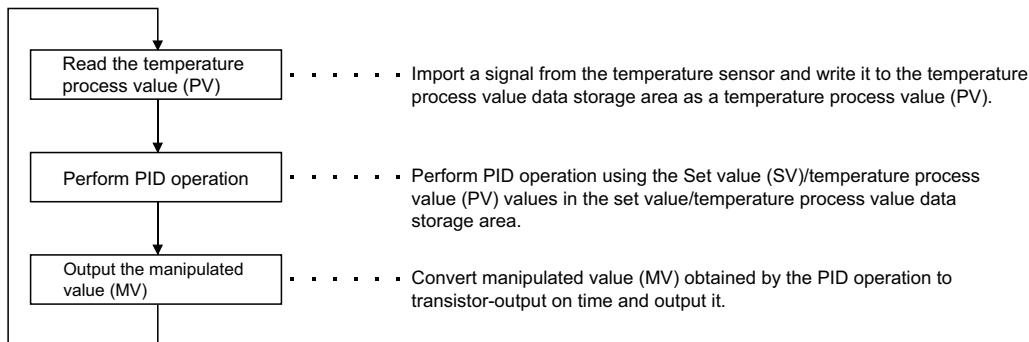

PID control (simple two-degree-of-freedom)

The temperature control module operates in "simple two-degree-of-freedom". In the simple two-degree-of-freedom PID control, the parameters of the two-degree-of-freedom PID control are simplified and used for control.

In the simple two-degree-of-freedom PID control, the module controls target objects using not only PID constants but also a control response parameter. The parameter can be set to "fast", "normal", or "slow".

This setting can change the form of "response to the change of the set value (SV)" maintaining "response to the disturbance" in a good condition. (Page 53 Simple Two-degree-of-freedom)

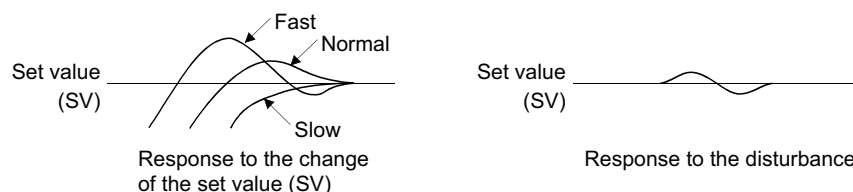

The following describes the difference between the one-degree-of-freedom PID control, two-degree-of-freedom PID control, and simple two-degree-of-freedom.

■ One-degree-of-freedom PID control and two-degree-of-freedom PID control

- General PID control is called one-degree-of freedom PID control. In the one-degree-of freedom PID control, when PID constants to improve the "response to the change of the set value (SV)" have been set, the "response to the disturbance" degrades. Conversely, when PID constants to improve the "response to the disturbance" have been set, the "response to the change of the set value (SV)" degrades.
- In the two-degree-of-freedom PID control, a manipulated value (MV) is determined considering a set value (SV) and variation amount. In the two-degree-of-freedom PID control, the "response to the change of the set value (SV)" and the "response to the disturbance" can be compatible with each other.

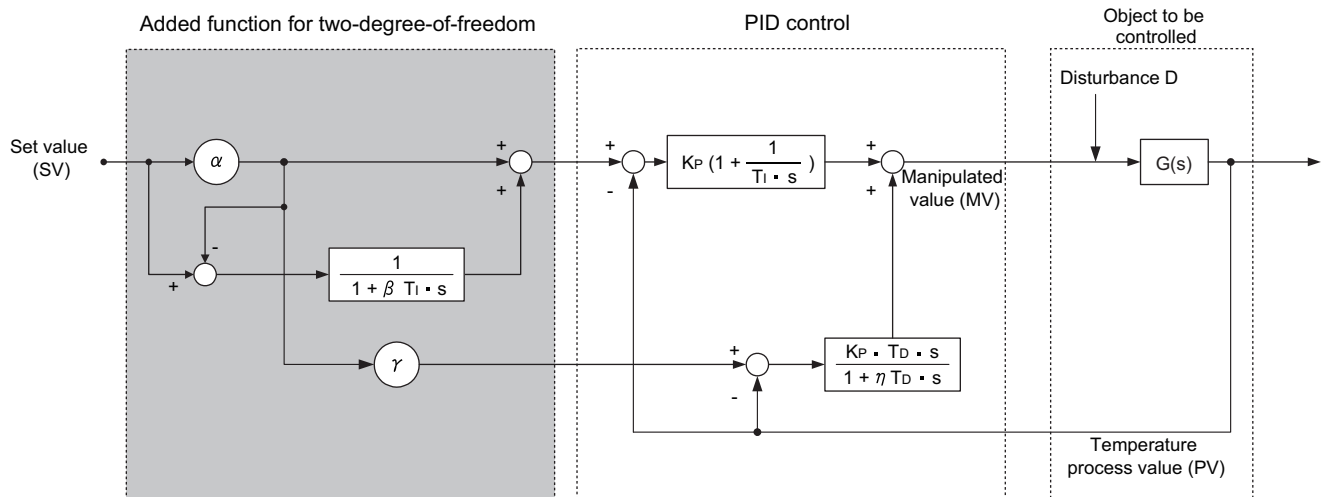

The appropriate setting of α , β , and γ in the above figure can achieve the optimum control. However, required parameter settings increase and PID constants can hardly be automatically set by the auto tuning function for complete two-degree-of-freedom PID control. Therefore, the temperature control module operates in the simple two-degree-of-freedom PID control for which parameters have been simplified.

PID operation

The temperature control module can execute the process-value inexact differential PID control.

Operation method and operational expression

The process-value inexact differential PID control is an operation method in which a primary delay filter has been put on the input of a derivative action and high-frequency noise has been eliminated to execute PID operations on the deviation (E).

Algorithm of the process-value inexact differential PID control

The following figure shows the algorithm of the process-value inexact differential PID control.

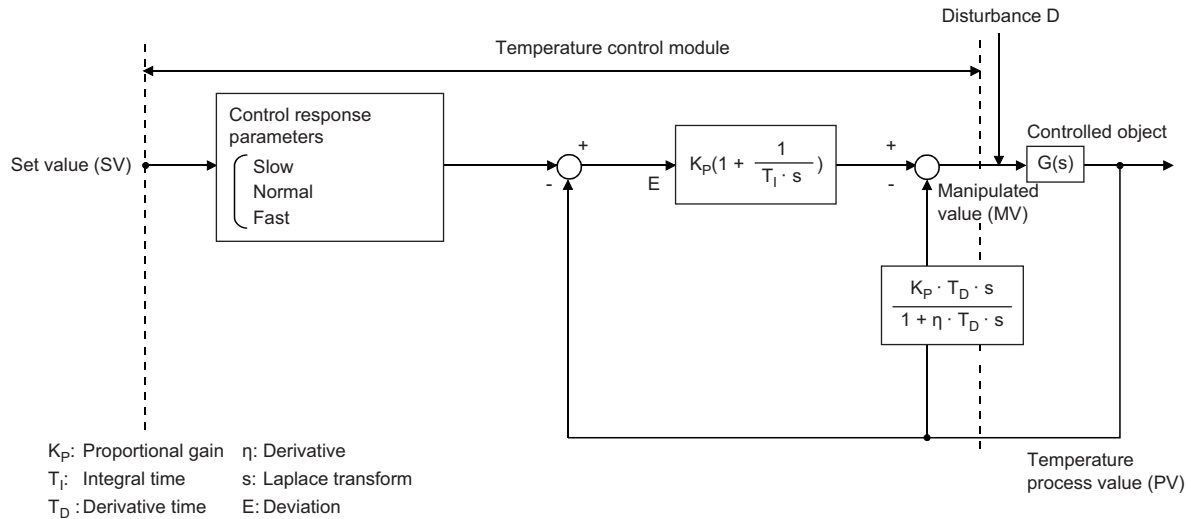

Operational expression

The following figure shows the operational expression of the temperature control module.

$$MV_n = K_p \left\{ E_n + \left(\frac{\tau}{T_i} E_n + I_{n-1} \right) + \left(\frac{\eta T_D}{\tau + \eta T_D} D_{n-1} - \frac{T_D}{\tau + \eta T_D} (PV_n - PV_{n-1}) \right) \right\}$$

- E: Deviation (SV-PV)
- τ : Sampling cycle
- MV: PID control in process-value incomplete derivation output
- PV: Process value
- K_p : Proportional gain
- T_i : Integral time
- T_D : Derivative time
- η : Derivative
- I: Integral value
- D: Derivative value



Point

The PID control in process-value derivation is an operation method in which the temperature process value (PV) is used as a derivative term in a PID operation. No deviation is used for the derivative term, drastic output changes due to a derivative action can be reduced when the deviation varies along with a set value change.

Actions of the temperature control module

The temperature control module executes PID operations with direct actions and reverse actions.

Direct action

In a direct action, the manipulated value (MV) increases when the temperature process value (PV) is larger than the set value (SV). A direct action is used for cooling control.

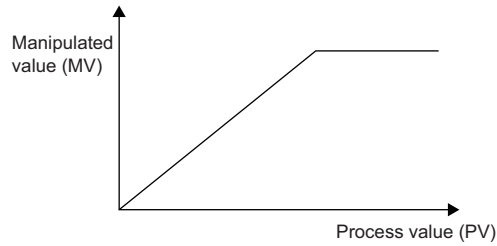

Reverse action

In a reverse action, the manipulated value (MV) increases when the temperature process value (PV) is smaller than the set value (SV). A reverse action is used for heating control.

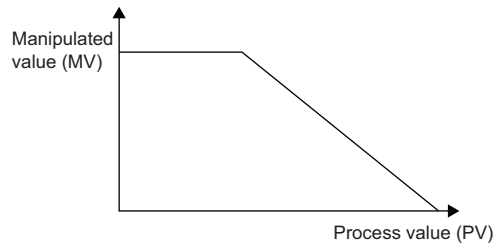

Proportional action (P action)

A proportional action is used to obtain the manipulated value (MV) proportional to the deviation (difference between the set value (SV) and the temperature process value (PV)).

Proportional gain

In a proportional action, the relation between changes in the deviation (E) and the manipulated value (MV) can be expressed in the following formula:

$$MV = K_P \cdot E$$

K_P is a proportional constant and is called proportional gain. The manipulated value (MV) varies within the range of -5.0% to 105.0%.

The following shows the difference of the actions depending on the proportional gain K_P .

Condition	Proportional action
When the proportional gain K_P is small	A control action slows down.
When the proportional gain K_P is large	A control action becomes fast. However, the temperature process value (PV) tends to fluctuate around the set value.

The following figure shows a proportional action of step responses of when the deviation (E) is a fixed value.

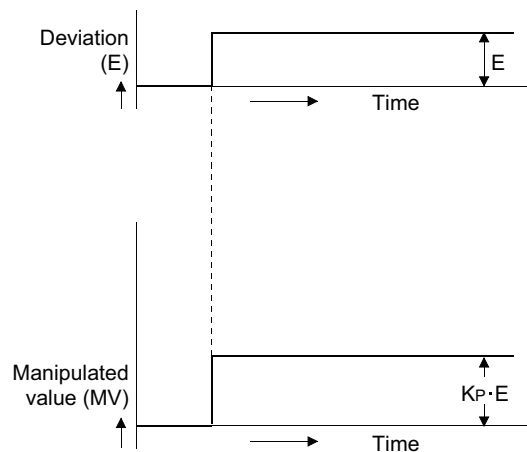

A

Offset

The certain amount of an error between the temperature process value (PV) and the set value (SV) is called an offset (remaining deviation). In a proportional action, an offset (remaining deviation) is generated.

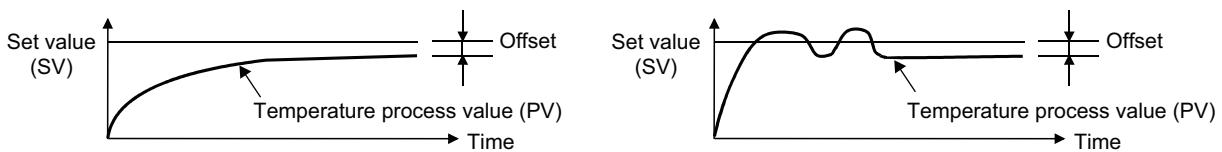

Integral action (I action)

An integral action that continuously changes the manipulated value (MV) to eliminate the deviation (E) when there is any. The offset caused by a proportional action can be eliminated.

In an integral action, the time taken for the manipulated value (MV) of the integral action after the generation of the deviation (E) to become the manipulated value (MV) of a proportional action is called integral time and expressed as T_I . The following shows the difference of the actions depending on the integral time T_I .

Condition	Integral action
When the integral time T_I is short	The integral effect becomes large and the time to eliminate the offset becomes short. However, the temperature process value (PV) tends to fluctuate around the set value.
When the integral time T_I is long	The integral effect becomes small and the time to eliminate the offset becomes long.

The following figure shows an integral action of step responses of when the deviation (E) is a fixed value.

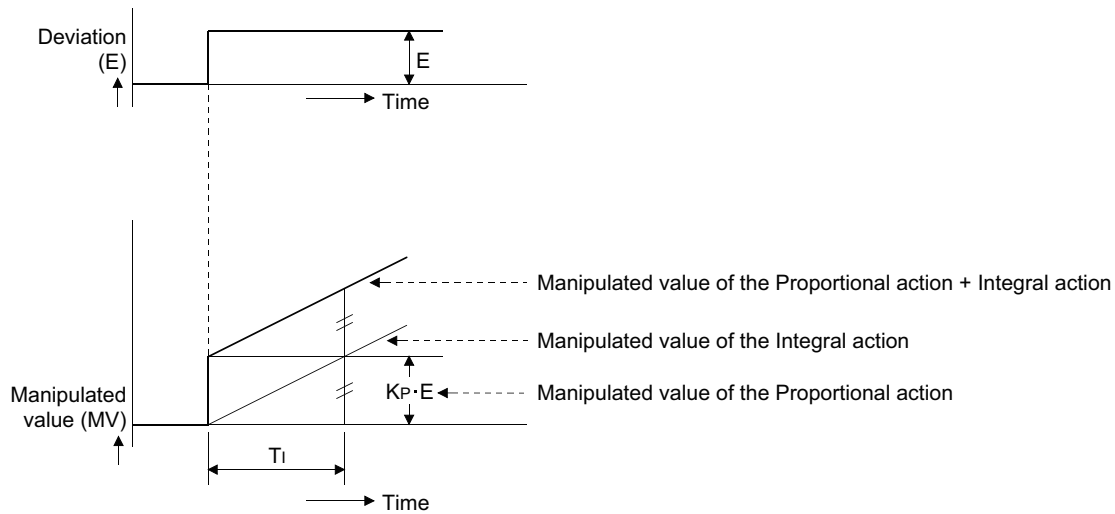

An integral action is used as a PI action in combination with a proportional action, or a PID action in combination with a proportional action and a derivative action. An integral action cannot be used by itself.

Derivative action (D action)

A derivative action adds the manipulated value (MV) proportional to the variation rate to eliminate the deviation (E) when it occurs. A derivative action can prevent the control target from changing significantly due to disturbance.

In a derivative action, the time taken for the manipulated value (MV) of the derivative action after the generation of the deviation (E) to become the value obtained by multiplying $\frac{1}{\eta} \times e^{-\frac{1}{\eta}}$ by the manipulated value (MV) of a proportional action is called derivative time and expressed as T_D .

Condition	Derivative action
When the derivative time T_D is short	The derivative effect becomes small.
When the derivative time T_D is long	The derivative effect becomes large. However, the temperature process value (PV) tends to fluctuate around the set value in short cycles.

The following figure shows a derivative action of step responses of when the deviation (E) is a fixed value.

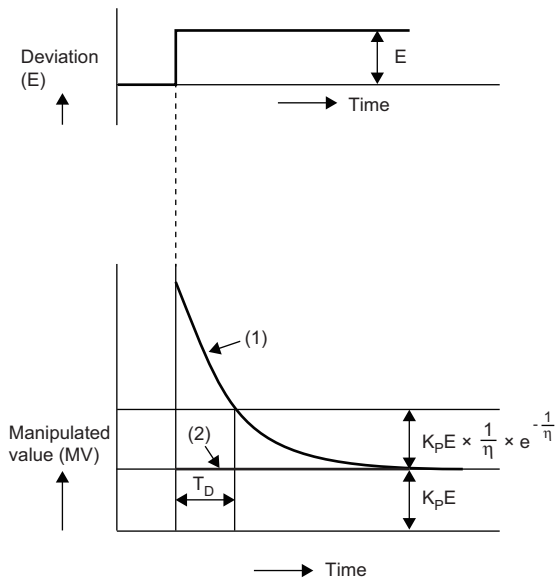

- (1) Manipulated value (MV) in a derivative action
- (2) Manipulated value (MV) in a proportional action

A derivative action is used as a PD action in combination with a proportional action, or PID action in combination with a proportional action and an integral action. A derivative action cannot be used by itself.

PID action

A PID action executes the control using the manipulated value (MV) calculated by adding the proportional action, integral action, and derivative action. The following figure shows a PID action of step responses of when the deviation (E) is a fixed value.

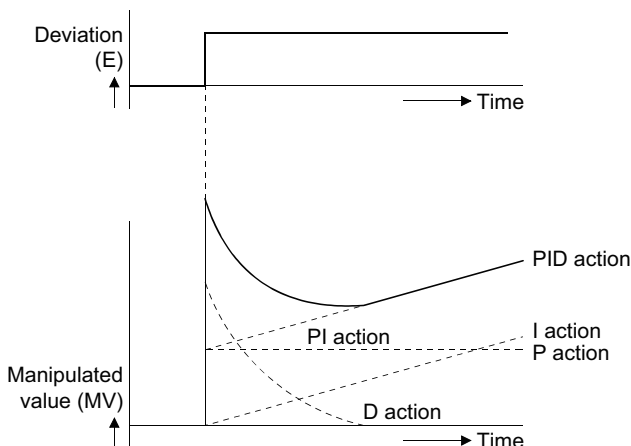

Appendix 5 Operation Examples of When the Remote Head Module Is Mounted

This section describes operation examples of when the remote head module is mounted

System configuration example

The following system configuration is used to explain an example of operation.

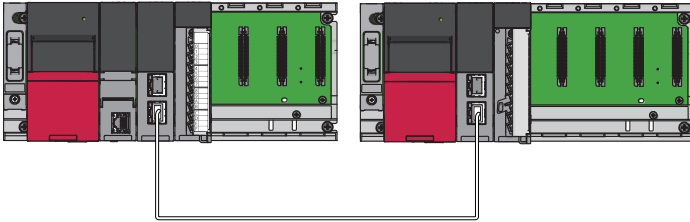

(1) Master station (Network number 1, station number 0)

- Power supply module: R61P
- CPU module: R120CPU
- Master/local module: RJ71GF11-T2 (Start I/O number: 0000H to 001FH)
- Input module: RX10 (Start I/O number: 0020H to 002FH)

(2) Intelligent device station (Network number 1, station number 1)

- Power supply module: R61P
- Remote head module: RJ72GF15-T2
- Temperature control module: R60TCTRT2TT2 (Start I/O number: 0000H to 000FH)*¹

*¹ In the RX/RX setting of the master station, set 1000H to 100FH as the start I/O number of the temperature control module.

Setting in the master station

Connect the engineering tool to the CPU module of the master station and set parameters.

1. Create the project with the following settings.

 [Project] ⇒ [New]

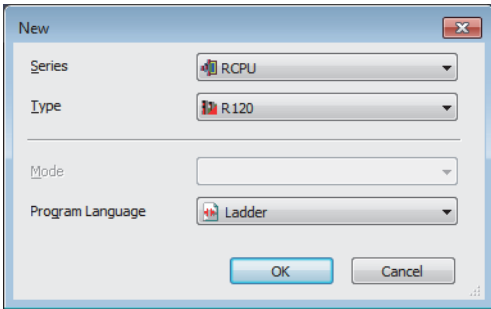

2. Configure the setting to use the module labels and add the module labels of the CPU module.

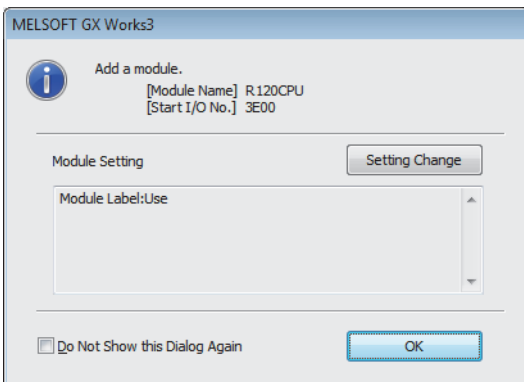

3. Add the master/local module with the following settings.

 [Navigation window] ⇒ [Parameter] ⇒ [Module Information] ⇒ Right-click ⇒ [Add New Module]

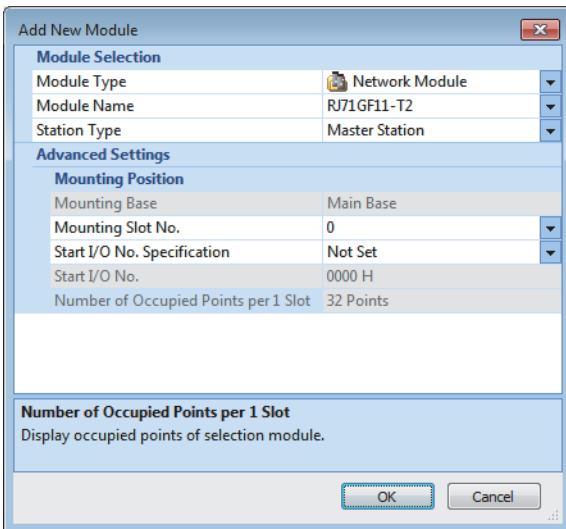

A

4. Click the [OK] button in the following window and add the module labels of the master/local module.

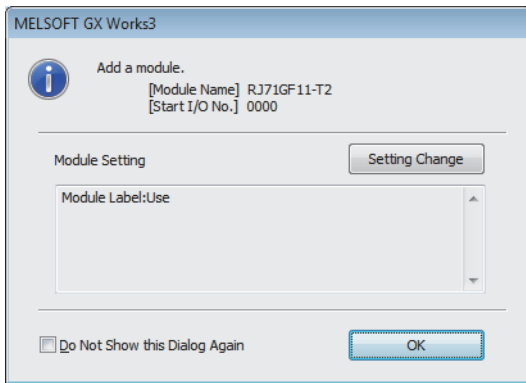

5. Set "Required Settings" of "Module Parameter" of the master/local module as shown below.

[Navigation window] ⇒ [Parameter] ⇒ [Module Information] ⇒ [RJ71GF11-T2] ⇒ [Module Parameter] ⇒ [Required Settings]

Item	Setting
Station Type	
Station Type	Master Station
Network Number	
Network Number	1
Station Number	
Setting Method	Parameter Editor
Station No.	0
Parameter Setting Method	
Setting Method of Basic/Application Settings	Parameter Editor

6. Set "Network Configuration Settings" of "Module Parameter" of the master/local module as shown below.

[Navigation window] ⇒ [Parameter] ⇒ [Module Information] ⇒ [RJ71GF11-T2] ⇒ [Module Parameter] ⇒ [Basic Settings] ⇒ [Network Configuration Settings]

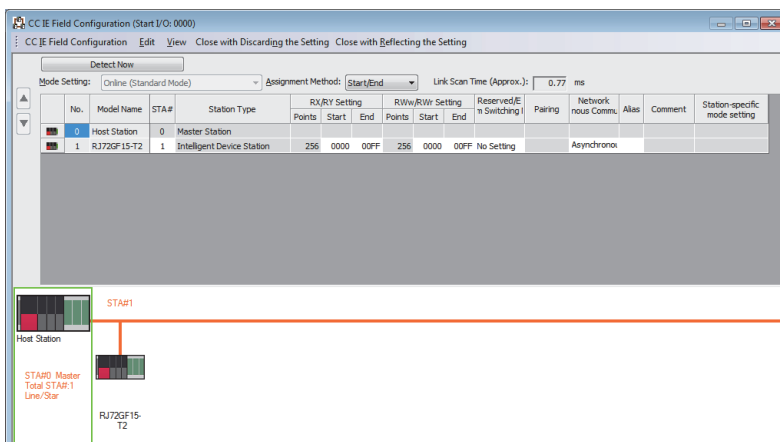

7. Set "Refresh Setting" of "Module Parameter" of the master/local module as shown below.

[Navigation window] ⇒ [Parameter] ⇒ [Module Information] ⇒ [RJ71GF11-T2] ⇒ [Module Parameter] ⇒ [Basic Settings] ⇒ [Refresh Setting]

No.	Link Side					CPU Side				
	Device Name	Points	Start	End		Target	Device Name	Points	Start	End
-	SB	512	00000	001FF	↔	Module Lab				
-	SW	512	00000	001FF	↔	Module Lab				
1	RX	256	00000	000FF	↔	Specify Devi	X	256	01000	010FF
2	RY	256	00000	000FF	↔	Specify Devi	Y	256	01000	010FF
3	RWr	256	00000	000FF	↔	Specify Devi	W	256	00000	000FF
4	RWw	256	00000	000FF	↔	Specify Devi	W	256	01000	010FF
5					↔					

8. Write the set parameters to the CPU module on the master station. Then reset the CPU module or power off and on the system.

 [Online] ⇄ [Write to PLC]

Point 

For parameters of the master/local module which are not described in this procedure, set default values. For details on parameters of the master/local module, refer to the following.

 MELSEC iQ-R CC-Link IE Field Network User's Manual (Application)

Setting in the intelligent device station

Connect the engineering tool to the remote head module of the intelligent device station and set parameters.

1. Create the project with the following settings.

[Project] ⇒ [New]

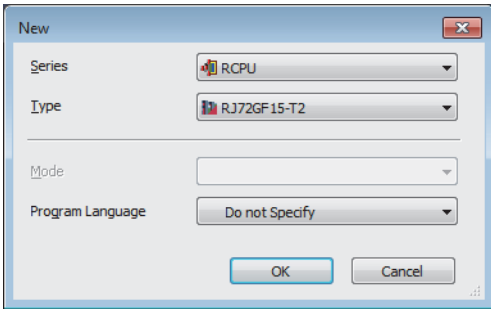

2. Set "Network Required Setting" of "CPU Parameter" of the remote head module as shown below.

[Navigation window] ⇒ [Parameter] ⇒ [RJ72GF15-T2] ⇒ [CPU Parameter] ⇒ [Network Required Setting]

Item	Setting
Network Number	
Network Number	1
Station Number	
Station No.	1

3. Add the temperature control module with the following settings.

[Navigation window] ⇒ [Parameter] ⇒ [Module Information] ⇒ Right-click ⇒ [Add New Module]

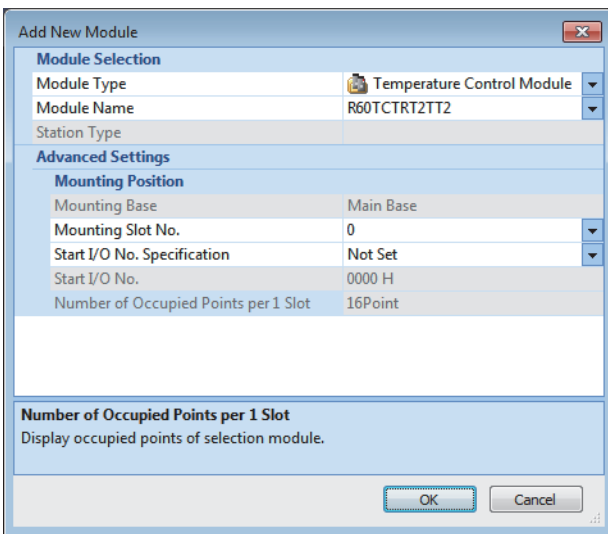

4. Configure the setting not to use the module labels.

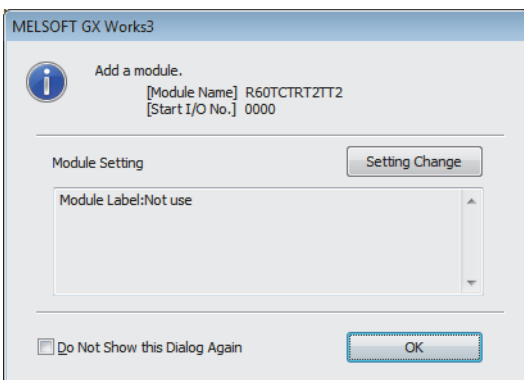

5. Set "Basic Setting" of "Module Parameter" of the temperature control module as shown below.

[Navigation window] ⇒ [Parameter] ⇒ [Module Information] ⇒ [R60TCTRT2TT2] ⇒ [Module Parameter] ⇒ [Basic Setting]

Item	CH1	CH2	CH3	CH4
HOLD/CLEAR setting	I set the output of the CPU stop error.			
HOLD/CLEAR setting	0: CLEAR	0: CLEAR	0: CLEAR	0: CLEAR
Control mode selection	I set the control mode.			
Control mode selection	0: Standard Control			
Sampling cycle selection	Set the sampling cycle.			
Sampling cycle selection	0: 500ms/4 channels			
Automatic setting at input range change	Select the automatic setting at input range change.			
Automatic setting at input range change	0: Disable			
Setting change rate limiter setting	Set the setting change rate limiter setting.			
Setting change rate limiter setting	0: Temperature Rise/Temperature Drop Batch Setting			
Control output cycle unit selection setting	Set the unit of the control output cycle.			
Control output cycle unit selection setting	0: 1s units			
Moving averaging process setting	You can set the moving average processing.			
Moving averaging process setting	0: Enable			
Multiple module interaction function	Set the multiple module interaction function.			
Peak current suppression function enable/disable	0: Disable			
Peak current suppression function master/slave se	0: Slave			
Simultaneous temperature rise function enable/dis	0: Disable			
Simultaneous temperature rise function master/sla	0: Slave			

6. Set "Application Setting" of "Module Parameter" of the temperature control module as shown below.

[Navigation window] ⇒ [Parameter] ⇒ [Module Information] ⇒ [R60TCTRT2TT2] ⇒ [Module Parameter] ⇒ [Application Setting]

- "Control basic parameters"

Set "Target Value (SV) Setting" of CH1 and "Unused channel setting" of CH2 to CH4 as shown below.

Item	CH1	CH2	CH3	CH4
Control basic parameters	Set the control basic parameters.			
Input range setting	2: Thermocouple K Measur	2: Thermocouple K Meas	2: Thermocouple K Measur	2: Thermocouple K Meas
Target Value(SV) Setting	200 °C	0 °C	0 °C	0 °C
Unused channel setting	0: Used	1: Unused	1: Unused	1: Unused
Control output cycle setting	30 s	30 s	30 s	30 s
Control Response Parameters	0: Slow	0: Slow	0: Slow	0: Slow
Stop mode setting	1: Monitor	1: Monitor	1: Monitor	1: Monitor
PID continuation Flag	0: Stop			

7. Set "Refresh" of "Module Parameter" of the temperature control module as shown below.

[Navigation window] ⇒ [Parameter] ⇒ [Module Information] ⇒ [R60TCTRT2TT2] ⇒ [Module Parameter] ⇒ [Refresh]

Item	CH1	CH2	CH3	CH4
Transfer to PLC	The data on buffer memory will be transferred to specified device.			
Latest error code	W1050			
Error occurrence address				
Latest address of error history				
Latest alarm code				
Latest address of alarm history				
Temperature process value (PV)				
Manipulated value (MV)				
Transistor output flag				
Warning Occurrence Contents				
Manipulated value (MV) for output with another analog module				
Temperature rise judgment flag				
Set value (SV) monitor				
AT Simultaneous temperature rise parameter calculation flag				
Self-tuning flag				
Temperature conversion completion flag				
Process value (PV) scaling value				
Simultaneous temperature rise status				
Manipulated value for cooling (MVc)				
Cooling-side transistor output flag				

8. Write the set parameters to the remote head module on the intelligent device station. Then reset the remote head module or power off and on the system.

[Online] ⇒ [Write to PLC]

Point

For parameters of the master/local module which are not described in this procedure, set default values. For details on parameters of the master/local module, refer to the following.

📖 MELSEC iQ-R CC-Link IE Field Network Remote Head Module User's Manual (Application)

Checking the network status

After setting parameters to the master station and the intelligent device station, check whether data link is normally performed between the master station and the intelligent device station. Check the network status using the CC-Link IE Field Network diagnostics of the engineering tool.

For how to perform the CC-Link IE Field Network diagnostics from the master station, refer to the following.

 MELSEC iQ-R CC-Link IE Field Network User's Manual (Application)

Program examples

For the program examples, the module labels of the master/local module are used.

Write the programs to the CPU module on the master station.

Classification	Label name	Description	Device																																																						
Module label	GF11_1.bnSts_DataLinkError	Data link error status of own station	SB0049																																																						
	GF11_1.bnSts_DataLinkError_Station[1]	Data link status of each station (station number 1)	SW00B0.0																																																						
Labels to be defined	Define global labels as shown below:																																																								
	<table border="1"> <thead> <tr> <th></th> <th>Label Name</th> <th>Data Type</th> <th>Class</th> <th>Assign (Device/Label)</th> <th>Comment</th> </tr> </thead> <tbody> <tr> <td>1</td> <td>Connect_FormationFlg_St1</td> <td>Bit</td> <td>VAR_GLOBAL</td> <td>M0</td> <td></td> </tr> <tr> <td>2</td> <td>MovementModeSettingOrder</td> <td>Bit</td> <td>VAR_GLOBAL</td> <td>X21</td> <td></td> </tr> <tr> <td>3</td> <td>ErrResetReq</td> <td>Bit</td> <td>VAR_GLOBAL</td> <td>X22</td> <td></td> </tr> <tr> <td>4</td> <td>SettingOperationModeCommand</td> <td>Bit</td> <td>VAR_GLOBAL</td> <td>Y1001</td> <td></td> </tr> <tr> <td>5</td> <td>ErrorResetCommand</td> <td>Bit</td> <td>VAR_GLOBAL</td> <td>Y1002</td> <td></td> </tr> <tr> <td>6</td> <td>SettingChangeCommand</td> <td>Bit</td> <td>VAR_GLOBAL</td> <td>Y100B</td> <td></td> </tr> <tr> <td>7</td> <td>ErrorFlag</td> <td>Bit</td> <td>VAR_GLOBAL</td> <td>X1002</td> <td></td> </tr> <tr> <td>8</td> <td>ErrorCode</td> <td>Word [Signed]</td> <td>VAR_GLOBAL</td> <td>W1050</td> <td></td> </tr> </tbody> </table>		Label Name	Data Type	Class	Assign (Device/Label)	Comment	1	Connect_FormationFlg_St1	Bit	VAR_GLOBAL	M0		2	MovementModeSettingOrder	Bit	VAR_GLOBAL	X21		3	ErrResetReq	Bit	VAR_GLOBAL	X22		4	SettingOperationModeCommand	Bit	VAR_GLOBAL	Y1001		5	ErrorResetCommand	Bit	VAR_GLOBAL	Y1002		6	SettingChangeCommand	Bit	VAR_GLOBAL	Y100B		7	ErrorFlag	Bit	VAR_GLOBAL	X1002		8	ErrorCode	Word [Signed]	VAR_GLOBAL	W1050			
	Label Name	Data Type	Class	Assign (Device/Label)	Comment																																																				
1	Connect_FormationFlg_St1	Bit	VAR_GLOBAL	M0																																																					
2	MovementModeSettingOrder	Bit	VAR_GLOBAL	X21																																																					
3	ErrResetReq	Bit	VAR_GLOBAL	X22																																																					
4	SettingOperationModeCommand	Bit	VAR_GLOBAL	Y1001																																																					
5	ErrorResetCommand	Bit	VAR_GLOBAL	Y1002																																																					
6	SettingChangeCommand	Bit	VAR_GLOBAL	Y100B																																																					
7	ErrorFlag	Bit	VAR_GLOBAL	X1002																																																					
8	ErrorCode	Word [Signed]	VAR_GLOBAL	W1050																																																					

Common program

The following figure shows an example of the program to check the data link status of the remote head module (station number 1).

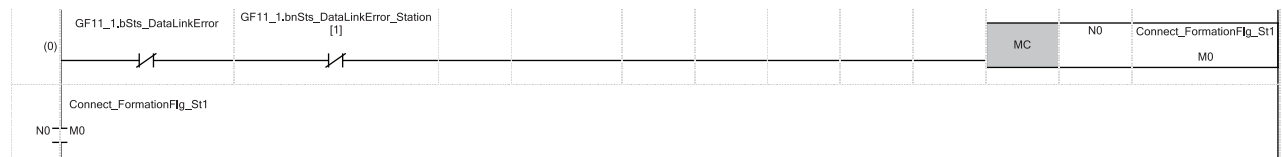

(0) Checks the data link status of the remote head module (station number 1).

Add the MCR instruction shown below to the last of the program.



Program to change the setting/operation mode



Program to clear the error code

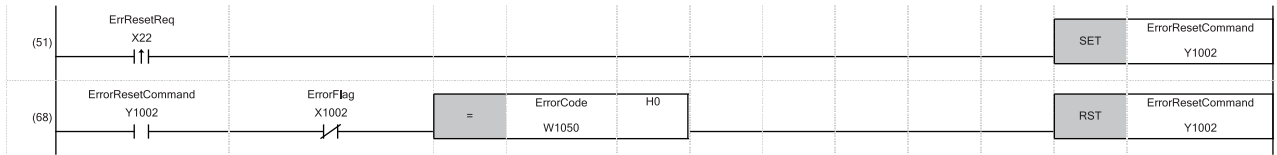

Appendix 6 Restrictions for When the Remote Head Module Is Mounted

This section describes restrictions on using a temperature control module together with the remote head module.

- The inter-module link function cannot be used between the temperature control module on the master station and the temperature control module on the intelligent device station.
- For the HOLD/CLEAR setting, refer to the following.

 Page 24 HOLD/CLEAR Function

For restrictions other than the above, refer to the following.

 MELSEC iQ-R CC-Link IE Field Network Remote Head Module User's Manual (Startup)

 MELSEC iQ-R CC-Link IE Field Network Remote Head Module User's Manual (Application)

Appendix 7 Added or Enhanced Function

The following table lists the added or enhanced function in the temperature control module.

Added or enhanced function	Firmware version
Supporting the remote head module redundant system	"02" or later

MEMO

INDEX

A

Alarm history	311
Alert flag	157
Alert with re-wait	75
Alert with wait	74
Auto tuning command	158
Auto tuning status	153
Automatic setting at input range change	219
Automatic setting monitor at input range change	209

B

Buffer memory	13
-------------------------	----

C

CH1 Adjustment sensitivity (dead band) setting	262
CH1 Alert 1 mode setting	272
CH1 Alert 2 mode setting	274
CH1 Alert 3 mode setting	274
CH1 Alert 4 mode setting	275
CH1 Alert dead band setting	271
CH1 Alert definition	224
CH1 Alert set value 1	241
CH1 Alert set value 2	242
CH1 Alert set value 3	242
CH1 Alert set value 4	243
CH1 AT bias	280
CH1 AT simultaneous temperature rise parameter calculation flag	233
CH1 Auto tuning error judgment time	279
CH1 Auto tuning mode selection	278
CH1 AUTO/MAN mode shift	263
CH1 Automatic backup setting after auto tuning of PID constants	281
CH1 Close side transistor output flag	231
CH1 Control motor time	269
CH1 Control output cycle setting	253
CH1 Control response parameter	254
CH1 Cooling control output cycle setting	266
CH1 Cooling method setting	266
CH1 Cooling method setting [Q compatible mode]	266
CH1 Cooling proportional band (Pc) setting	244
CH1 Cooling transistor output flag	230
CH1 Cooling upper limit output limiter	265
CH1 Decimal point position	223
CH1 Derivative action selection	267
CH1 Derivative time (D) setting	241
CH1 Direct/reverse action setting	261
CH1 Disturbance judgment position	288
CH1 During AT loop disconnection detection function enable/disable	279
CH1 Feed forward control forced start READY flag	237
CH1 Feed forward control forced start status	235
CH1 Feed forward control forced starting signal	290
CH1 Feed forward control READY flag	236

CH1 Feed forward value	291
CH1 Feed forward value memory read command	245
CH1 Feed forward value tuning flag	235
CH1 Feed forward value tuning selection	292
CH1 Heater disconnection alert setting	300
CH1 Heater disconnection judgment mode	301
CH1 Heating control output cycle setting	254
CH1 Heating proportional band (Ph) setting	240
CH1 Heating transistor output flag	228
CH1 Heating upper limit output limiter	257
CH1 HOLD/CLEAR setting	246
CH1 Input range	247
CH1 Integral time (I) setting	240
CH1 Integration output limiter setting	269
CH1 Loop disconnection detection dead band	276
CH1 Loop disconnection detection judgment time	275
CH1 Lower limit output limiter	257
CH1 Lower limit setting limiter	260
CH1 MAN output setting	264
CH1 Manipulated value (MV)	226
CH1 Manipulated value (MV) for output with another analog module	229
CH1 Manipulated value for cooling (MVc)	227
CH1 Manipulated value for cooling (MVc) for output with another analog module	230
CH1 Manipulated value for heating (MVh)	226
CH1 Manipulated value for heating (MVh) for output with another analog module	230
CH1 Manual reset amount setting	263
CH1 Memory's PID constants read command	244
CH1 Number of alert delay	272
CH1 Number of moving averaging setting	298
CH1 Open side transistor output flag	229
CH1 Open/close output neutral band setting	268
CH1 Output variation amount limiter	258
CH1 Overlap/dead band setting	267
CH1 Overshoot suppression level setting	293
CH1 Peak current suppression control group setting	284
CH1 Primary delay digital filter setting	293
CH1 Process value (PV) scaling function enable/disable setting	282
CH1 Process value (PV) scaling lower limit value	283
CH1 Process value (PV) scaling upper limit value	283
CH1 Process value (PV) scaling value	233
CH1 Proportional band (P) setting	238
CH1 Rate alarm alert detection cycle	277
CH1 Rate alarm alert output enable/disable setting	277
CH1 Rate alarm lower limit value	278
CH1 Rate alarm upper limit value	277
CH1 Self-tuning flag	231
CH1 Self-tuning setting	282
CH1 Sensor correction function selection	294
CH1 Sensor correction value setting	295
CH1 Sensor two-point correction gain latch completion	237

CH1 Sensor two-point correction gain latch request	296
CH1 Sensor two-point correction gain value (corrected value)	298
CH1 Sensor two-point correction gain value (measured value)	297
CH1 Sensor two-point correction offset latch completion	237
CH1 Sensor two-point correction offset latch request	295
CH1 Sensor two-point correction offset value (corrected value)	297
CH1 Sensor two-point correction offset value (measured value)	296
CH1 Set value (SV) monitor	229
CH1 Set value (SV) setting	238
CH1 Set value return adjustment	290
CH1 Setting variation rate limiter (temperature drop)	261
CH1 Setting variation rate limiter unit time setting	268
CH1 Setting variation rate limiter/setting variation rate limiter (temperature rise)	260
CH1 Simultaneous temperature rise AT mode selection	288
CH1 Simultaneous temperature rise dead time	287
CH1 Simultaneous temperature rise gradient data	287
CH1 Simultaneous temperature rise group setting	285
CH1 Simultaneous temperature rise status	234
CH1 Stop mode setting	252
CH1 Temperature process value (PV)	225
CH1 Temperature process value (PV) for input with another analog module	244
CH1 Temperature rise completion range setting	255
CH1 Temperature rise completion soak time setting	255
CH1 Temperature rise judgment flag	227
CH1 Transistor output flag	228
CH1 Unused channel setting	251
CH1 Upper limit output limiter	256
CH1 Upper limit setting limiter	259
CH1 Valve operation setting during CPU module STOP	270
Cold junction temperature compensation selection	222
Cold junction temperature process value	211
Condition target channel setting [n]	217
Condition target setting [n]	216
Control method	13
Control mode	13
Control mode selection	218
Control mode selection monitor	208
Control output cycle unit monitor	209
Control output cycle unit selection setting	220
CPU module	13
CT monitor method selection	300
CT1 CT input channel assignment setting	303
CT1 CT ratio setting	306
CT1 CT selection	303
CT1 CT selection [Q compatible mode]	304
CT1 Heater current process value	302
CT1 Reference heater current value	306

D

Default setting registration command	159
Default value write completion flag	155
Deviation alert	69
During AT loop disconnection detection function enable/disable [Q compatible mode]	280

E

Engineering tool	13
Error address	207
Error flag	152
Error history	310
Error reset command	158
Expanded mode	15

F

Feed forward value memory read completion flag	214
Function extension bit monitor [Q compatible mode]	312

H

Hardware error flag	152
Heater disconnection correction function selection	299
Heater disconnection/output off-time current error detection delay count	299
Heating-cooling control	14
HOLD/CLEAR setting [Q compatible mode]	246

I

Input alert	69
Inter-module peak current suppression function enable/disable monitor	307
Inter-module peak current suppression function master/slave selection monitor	307
Inter-module peak current suppression function state monitor	307
Inter-module simultaneous temperature rise function enable/disable monitor	309
Inter-module simultaneous temperature rise function master/slave selection monitor	309
Inter-module simultaneous temperature rise function state monitor	308
Interrupt factor detection flag [n]	208
Interrupt factor generation setting [n]	216
Interrupt factor mask [n]	215
Interrupt factor reset request [n]	215

L

Latest address of alarm history	208
Latest address of error history	207
Latest alarm code	207
Latest error code	207
Lower limit deviation alert	71

M

MAN mode shift completion flag	210
--------------------------------	-----

Manipulated value resolution change for output with another analog module	221
Memory's PID constants read completion flag . .	211
Memory's PID constants read/write completion flag [Q compatible mode].	213
Memory's PID constants write completion flag . .	212
Module READY flag	150
Moving average processing setting	220
Moving average processing setting monitor	209

N

Number of slave modules with inter-module peak current suppression function enabled	308
Number of slave modules with inter-module simultaneous temperature rise function enabled	309

P

P control	18
PD control	19
Peak current suppression control group setting [Q compatible mode].	284
PI control	19
PID constants	13
PID continuation flag	220
PID control	20
PID control forced stop command	160
Position-proportional control	14

Q

Q compatible mode	13
-----------------------------	----

R

R mode	13
Refresh processing time	136

S

Sampling cycle and function extension setting [Q compatible mode].	313
Sampling cycle monitor	209
Sampling cycle selection	218
Sensor correction function selection [Q compatible mode].	294
Setting change command	160
Setting change completion flag	156
Setting value backup command	159
Setting value backup completion flag	154
Setting value backup failure flag	156
Setting variation rate limiter setting selection . . .	219
Setting variation rate limiter setting selection monitor	209
Setting/operation mode command	158
Setting/operation mode status	151
Simultaneous temperature rise parameter	13
Standard control	14
Start I/O of slave module with inter-module peak current suppression function enabled	308
Start I/O of slave module with inter-module simultaneous temperature rise function enabled	310

T

Temperature conversion completion flag	210
Temperature conversion completion flag [Q-compatible mode].	210
Temperature conversion setting	264
Transistor output monitor ON delay time setting . .	221
Two-position control	16

U

Upper limit deviation alert	71
Upper/lower limit deviation alert	72

W

Within-range alert	72
------------------------------	----

REVISIONS

*The manual number is given on the bottom left of the back cover.

Revision date	*Manual number	Description
July 2015	SH(NA)-081536ENG-A	First edition
May 2016	SH(NA)-081536ENG-B	■Added or modified parts RELEVANT MANUALS, TERMS, Section 1.5, 1.11, 1.19, 1.37, 3.4, Appendix 5, 6, 7
February 2018	SH(NA)-081536ENG-C	■Added or modified parts Appendix 3

Japanese manual number SH-081534-C

This manual confers no industrial property rights of any other kind, nor does it confer any patent licenses. Mitsubishi Electric Corporation cannot be held responsible for any problems involving industrial property rights which may occur as a result of using the contents noted in this manual.

© 2015 MITSUBISHI ELECTRIC CORPORATION

WARRANTY

Please confirm the following product warranty details before using this product.

1. Gratis Warranty Term and Gratis Warranty Range

If any faults or defects (hereinafter "Failure") found to be the responsibility of Mitsubishi occurs during use of the product within the gratis warranty term, the product shall be repaired at no cost via the sales representative or Mitsubishi Service Company.

However, if repairs are required onsite at domestic or overseas location, expenses to send an engineer will be solely at the customer's discretion. Mitsubishi shall not be held responsible for any re-commissioning, maintenance, or testing on-site that involves replacement of the failed module.

[Gratis Warranty Term]

The gratis warranty term of the product shall be for one year after the date of purchase or delivery to a designated place. Note that after manufacture and shipment from Mitsubishi, the maximum distribution period shall be six (6) months, and the longest gratis warranty term after manufacturing shall be eighteen (18) months. The gratis warranty term of repair parts shall not exceed the gratis warranty term before repairs.

[Gratis Warranty Range]

- (1) The range shall be limited to normal use within the usage state, usage methods and usage environment, etc., which follow the conditions and precautions, etc., given in the instruction manual, user's manual and caution labels on the product.
- (2) Even within the gratis warranty term, repairs shall be charged for in the following cases.
 1. Failure occurring from inappropriate storage or handling, carelessness or negligence by the user. Failure caused by the user's hardware or software design.
 2. Failure caused by unapproved modifications, etc., to the product by the user.
 3. When the Mitsubishi product is assembled into a user's device, Failure that could have been avoided if functions or structures, judged as necessary in the legal safety measures the user's device is subject to or as necessary by industry standards, had been provided.
 4. Failure that could have been avoided if consumable parts (battery, backlight, fuse, etc.) designated in the instruction manual had been correctly serviced or replaced.
 5. Failure caused by external irresistible forces such as fires or abnormal voltages, and Failure caused by force majeure such as earthquakes, lightning, wind and water damage.
 6. Failure caused by reasons unpredictable by scientific technology standards at time of shipment from Mitsubishi.
 7. Any other failure found not to be the responsibility of Mitsubishi or that admitted not to be so by the user.

2. Onerous repair term after discontinuation of production

- (1) Mitsubishi shall accept onerous product repairs for seven (7) years after production of the product is discontinued. Discontinuation of production shall be notified with Mitsubishi Technical Bulletins, etc.
- (2) Product supply (including repair parts) is not available after production is discontinued.

3. Overseas service

Overseas, repairs shall be accepted by Mitsubishi's local overseas FA Center. Note that the repair conditions at each FA Center may differ.

4. Exclusion of loss in opportunity and secondary loss from warranty liability

Regardless of the gratis warranty term, Mitsubishi shall not be liable for compensation to:

- (1) Damages caused by any cause found not to be the responsibility of Mitsubishi.
- (2) Loss in opportunity, lost profits incurred to the user by Failures of Mitsubishi products.
- (3) Special damages and secondary damages whether foreseeable or not, compensation for accidents, and compensation for damages to products other than Mitsubishi products.
- (4) Replacement by the user, maintenance of on-site equipment, start-up test run and other tasks.

5. Changes in product specifications

The specifications given in the catalogs, manuals or technical documents are subject to change without prior notice.

TRADEMARKS

The company names, system names and product names mentioned in this manual are either registered trademarks or trademarks of their respective companies.

In some cases, trademark symbols such as [™] or [®] are not specified in this manual.

SH(NA)-081536ENG-C(1802)KWIX

MODEL: R60TC-U-OU-E

MODEL CODE: 13JX39

mitsubishi electric corporation

HEAD OFFICE : TOKYO BUILDING, 2-7-3 MARUNOUCHI, CHIYODA-KU, TOKYO 100-8310, JAPAN
NAGOYA WORKS : 1-14, YADA-MINAMI 5-CHOME, HIGASHI-KU, NAGOYA, JAPAN

When exported from Japan, this manual does not require application to the
Ministry of Economy, Trade and Industry for service transaction permission.

Specifications subject to change without notice.